

# Air Knight<sup>®</sup> WITH IPG

IONIZED PARTICLE GATHERING

## SUBMITTAL

### AIR PURIFICATION SYSTEM

The Air Knight<sup>®</sup> Air Purification System is designed to be installed into an existing HVAC system and provide virtually maintenance free air purification. Please read and follow all service procedures outlined in the manual.

**Dimensions:** See Fig.1

**Weight:**  
Approx. 3 lbs.

**Warranty:**  
7-yr ballast. 2-yr cell.

Fig. 1 Dimensions of Air Knight unit.

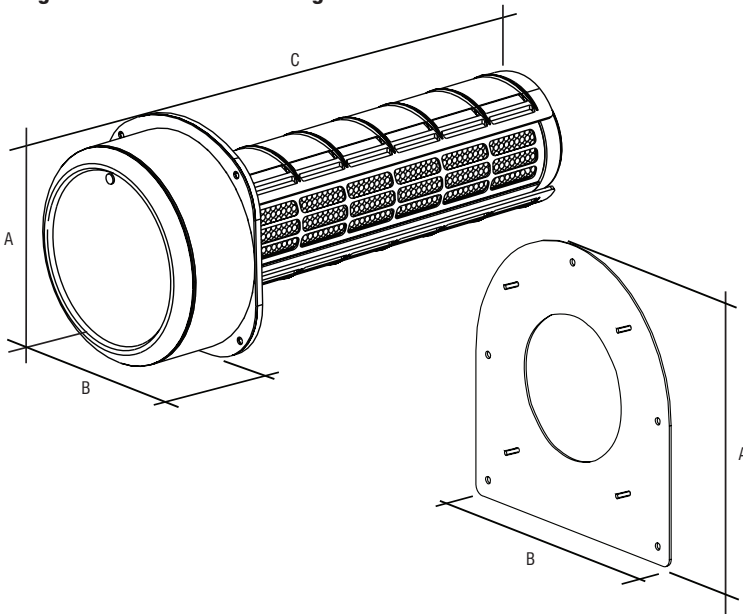

MODEL	DIM. A	DIM. B	DIM. C
7" Unit	6.5"	6"	9.9"
14" Unit	6.5"	6"	14.5"
M. Plate	7.875"	7.875"	

Specifications subject to change without notice.

**EPA Establishment No.: 73316-TX-1**

**TopTech**  
comfort | excellence

**Electrical:**

The unit uses an electronic power module. The device must be installed in compliance with all national and local electrical and mechanical codes. Always use a dedicated 40Va transformer. If connecting a second air purifier or UV light to auxiliary power port, use 75Va transformer.

Power Ratings: 24VAC 50/60 Hz.

Output: 19.2 Watts

**Temperature:**

45 F - 150 F (Outside of duct).

**Airflow:**

7" Unit - Up to 2000 CFM.

14" Unit - Up to 3000 CFM.

Air flow specification subject to pollutant levels.

Date: \_\_\_\_\_

Engineer: \_\_\_\_\_

Job Name: \_\_\_\_\_

Contractor: \_\_\_\_\_

Location: \_\_\_\_\_

Submitted By: \_\_\_\_\_