

TECUMSEH HERMETIC CONDENSING UNIT

AWA2453ZDXU
TPC__rev 02
October 21, 2003

Model **AWA2453ZDXU**
BOM **2W1119-1**

Water Cooled **1 1/4 HP**
Application **Low Temp**
Refrigerant **R 404A**

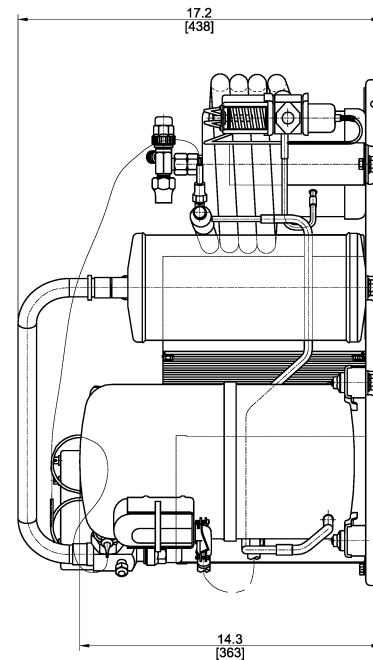
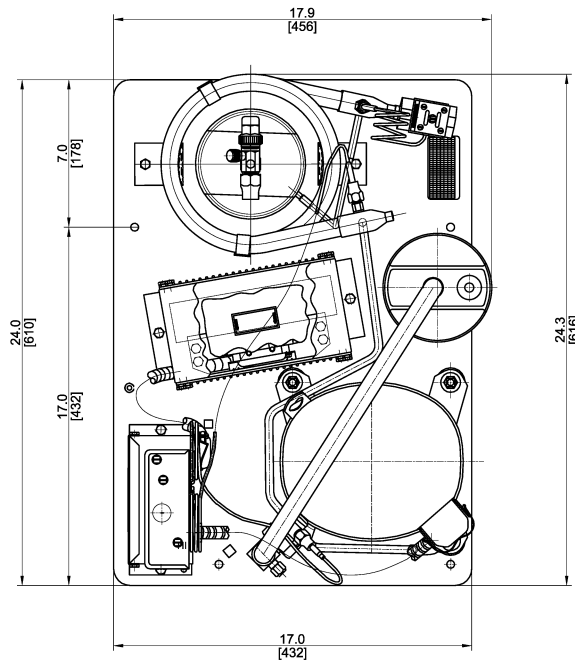
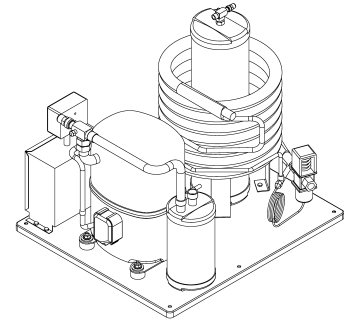

Model	Dimensions, inches				Line connection*		Pumdown	Oil Ch	Gr. Wt
	L	W	H	CH	Suction	Liquid	90° 90%	Oz.	Lbs.
AWA2453ZDXU	24.3	17.9	17.2	14.3	7/8"S	3/8"F	5.1	38.0	119.0
*) Use 3/8" min. pipe size. Water inlet 3/8" NPT									
Performance: Ambient 90 °F -- Return Gas 40 °F -- Condenser water in 75 °F -- Head 254 PSIG									
Evaporator temperature °F		-40	-30	-20	-10	0	10		
Capacity BTU/HR		1164	2109	3497	5282	7415	9847		
Water Usage gpm		0.30	0.60	0.90	1.40	1.90	2.50		
Watts		657	790	962	1160	1369	1575		
The water valve should be adjusted to maintain a maximum of 95°F water outlet temperature in order to minimize water scaling within the condenser.									

