

[®]**REZOR**

HYDRONIC UNIT HEATER CATALOG

COMMERCIAL/INDUSTRIAL HEATERS

FUEL

Steam or Hot Water

CAPACITIES

13 - 350 MBH

270 - 8,071 CFM

AIR DELIVERY

Propeller Fan

Visit www.RezSpec.com for more information.

Form C-HU (Version C)

BACKGROUND

Reznor was founded in 1888 to manufacture the “Reznor” reflector heater, which used a luminous flame gas burner developed by George Reznor. This technological breakthrough was an immediate success and hastened the expansion of gas heating in residential and commercial applications. Technological development and innovation have been the hallmark of Reznor products through the years. The development of the forced air gas unit heater, the modular Thermocore® heat exchanger, and the high-efficiency, V3® Series Unit Heater with the Tcore2® single-burner and innovative heat exchanger system, have kept Reznor products at the forefront of technological advances in commercial and industrial gas heating. As a result of this pioneering role in the heating, makeup air, and ventilating equipment field, the products offered today are the most advanced in engineering design to satisfy a wide variety of applications.

FACILITIES

Reznor heaters were first manufactured and sold in Mercer, Pennsylvania (70 miles north of Pittsburgh) in 1888. Over the years, the company has grown and expanded. Today, with sales worldwide, Reznor products are being manufactured at facilities throughout North America and Europe.

PRODUCT SCOPE

Well-equipped engineering laboratories for both product development and testing can be found at many of the manufacturing sites. All domestic lab sites are agency approved.

Reznor Products include a complete line of heating, makeup air, air conditioning and ventilating systems, using gas, oil, hot water/steam, or electric heating or cooling sources. Reznor catalogs are designed to aid the engineer, architect or contractor in specifying the correct equipment for all standard and special applications. Complete data is presented on unit heaters, duct furnaces, infrared heaters, makeup air systems, pre-engineered custom-designed systems, packaged cooling equipment, energy recovery and evaporative cooling modules. Consult your local Reznor Sales Representative for further assistance in specifying Reznor Equipment for your specific application.

SERVICES

Product service requirements are handled through contractors and/or distributors, with backup from local representatives and factory-based service team. Replacement parts inventories for both warranty and non-warranty requirements are maintained at service centers throughout the country and at the manufacturing facilities.

REZNOR®

**INDOOR, SUSPENDED,
STEAM OR HOT WATER
HYDRONIC UNIT HEATER
FOR VERTICAL OR HORIZONTAL
CONFIGURATION**

REZNOR®



Contents	
MODEL WS	2
STANDARD FEATURES.....	2
TECHNICAL DATA.....	3
DIMENSIONS.....	3
ENGINEERING DATA.....	4
HOT WATER CAPACITIES, CALCULATIONS AND CORRECTION FACTORS.....	4
HEAT EXCHANGER RESISTANCE CHART.....	6
TERMS, ABBREVIATIONS AND FORMULAS.....	7
STEAM CAPACITIES, CALCULATIONS AND CORRECTION FACTORS...	8
EFFECTIVE HEAT COVER AND AIR THROW.....	10
CEILING INSTALLATION.....	12
OPTIONAL AIR FLOW INDUCTION OPTIMIZER.....	13
GENERAL LAYOUT.....	15
LIMITED PRODUCT WARRANTY.....	17

IMPORTANT: This guide is intended to provide specifications and technical information only.

This guide is NOT intended to be an instruction manual. When installing heating and ventilating equipment, you must check and conform to all local and national building codes. Improper installation of heating and ventilating equipment could be dangerous. Consult manufacturer's installation manual for instruction and important warnings.

In keeping with our policy of continuous product improvement, we reserve the right to alter, at any time, the design, construction, dimensions, weights, etc., of equipment information shown here.

REZNOR®**MODEL WS****INDOOR, SUSPENDED, STEAM OR HOT WATER
HYDRONIC UNIT HEATER FOR VERTICAL OR HORIZONTAL CONFIGURATION****DESCRIPTION**

Reznor® Model WS Steam/Hot Water Suspended Heaters are design-engineered to be technically advanced and esthetically pleasing which makes it the hydronic heater for the 21st century.

This smart new concept in commercial heating units will accommodate all architects who are looking for something new and different.

The heating range of Model WS is 13,000 to 350,000 BTUH. The air volume ranges from 270 to 4,750 CFM.

The heat exchanger is made of one or two rows of steel coils (standard or optional copper coils) with aluminum fins, with approximately 10-1/2 fins per inch (4 fins per cm). The spacing between the fins makes cleaning and maintenance of the heat exchanger easier, which is essential to keep the unit heater efficient.

The standard steel tubing is very strong and long lasting. Steel tubing is designed for hot water applications up to 150 psi.

The copper tubing used for the heating coil is very thick (0.03", 0.75 mm), making Reznor heating coils extremely sturdy and long lasting. The copper tube diameter is 0.867" (22 mm) O.D. The large tube diameter reduces the water pressure drop, which means these units require lower pump pressure than other hydronic heaters. It also allows a very rapid heat radiation. **For steam heating applications copper tube (Option HA12) is required.** Designed for high working steam pressure up to 145 psi (10 bar), every heat exchanger is subjected to a pressure test at over 350 psi (25 bar) before leaving the factory.

The heat exchanger assembly receives a special paint coating which makes the coil long lasting and increases the thermal output.

The Fan/Motor Assembly is made up of three components: the fan, the motor and the fan guard, which also acts as the main support for the fan. This fan guard is galvanized for protection against corrosion, and is mounted onto the main casing with anti-vibration rubber mountings. The fan guard meets OSHA requirements.*

The standard 2-speed motor is a hermetically sealed motor which is maintenance free. The motor is wired for 115/1/60 supply voltage. The motor speed is field adjustable to run at high or low RPMs. Refer to the Technical Data Chart for fan RPM, heating output and CFM ranges.

The flexibility of changing motor speeds allows the installer to adjust the unit to high speed for increased BTUH output, or low speed for reduced noise level. All motors have internal protection as a standard feature.

All Model WS units can be installed for either vertical or horizontal discharge.

The unit cabinet is manufactured from .032" (0.8mm) galvanized pre-painted steel finished in dove gray. Using pre-painted steel helps protect the cabinet against oxidation.

The cabinet is held together by shake-proof screws and molded corner sections to add additional strength and durability. Adjustable louvers are held in place by spring loaded pivots. Vertical louvers are available for field installation.

The optional Air Flow Induction Optimizer is available for horizontally discharged units. The Air Flow Induction Optimizer increases the air flow due to the unique shape of its deflecting louvers which improves the throw of the heated air stream. See the optional accessories section for more information.

Units are packaged into strong corrugated cardboard cartons with strengthened upper and lower side sections. These containers are clearly marked with the model number, size and approximate shipping weight.

Units are manufactured in an ISO 9001 registered facility.

STANDARD FEATURES

- Heat exchanger composed of steel tubes and aluminum fins spaced approximately 10-1/2 fins per inch
- Painted tubing heat exchanger and aluminum fins
- Hot water applications
- Fan/Motor Assembly includes galvanized fan guard
- Vertical or horizontal configuration
- Cabinet and louvers constructed of galvanized pre-painted steel
- Cabinet held together by shake-proof screws and molded corner sections
- Spring mounted horizontal louvers
- 115/60 single phase, two speed motor (field adjustable)
- Manufactured in an ISO 9001 registered facility

FACTORY INSTALLED OPTIONS

- Heat exchanger composed of 0.03" thick, .867" O.D copper tubes and aluminum fins spaced approximately 10-1/2 fins per inch
- Up to 145 psi steam applications with copper tubing

FIELD INSTALLED OPTIONS

- Vertical louvers for better air distribution - vertical or horizontal discharge
- Air flow induction louvers increase air flow and throw - horizontal discharge
- Light duty, or heavy duty thermostat
- Thermostat guard cover

**STANDARD FEATURES**

OSHA requires that the fan guard spacing for a heater mounted 7 feet off the floor can not exceed 1/2 inch.

REZNOR®

TECHNICAL DATA

		Fan Speed	Size								
			18/24	23/33	44/62	60/85	78/110	96/120	140/175	190/238	300/350
Maximum Heating Capacity ^A	MBH	Low	18	23	44	60	78	96	140	190	300
		High	24	33	62	85	110	120	175	238	350
	Watts	Low	5,276	6,741	12,896	17,586	22,862	28,138	41,034	55,689	87,930
		High	7,034	9,672	18,172	24,914	32,241	35,172	51,293	69,758	102,585
	kcal/hr	Low	4,536	5,796	11,089	15,121	19,657	24,194	35,282	47,883	75,605
		High	6,048	8,317	15,625	21,421	27,722	30,242	44,103	59,980	88,206
Maximum Leaving Air Temperature (L.A.T.) ^B	°F	Low	121°	124°	132°	129°	125°	134°	134°	140°	133°
		High	115°	121°	126°	123°	121°	131°	130°	137°	128°
	°C	Low	49°	51°	56°	54°	52°	57°	57°	62°	56°
		High	46°	49°	52°	51°	49°	55°	54°	58°	53°
Approximate Fan RPM		Low	1,100	1,100	1,100	1,100	1,100	850	850	850	850
		High	1,550	1,600	1,600	1,600	1,600	1,080	1,080	1,080	1,080
Motor HP		Low	0.014	0.020	0.027	0.048	0.090	0.041	0.070	0.110	0.500
115/1/60 Motor		High	0.040	0.055	0.082	0.150	0.260	0.090	0.160	0.250	1.140
Amp Rating		Low	0.3	0.4	0.6	1.1	1.7	0.9	1.1	2.2	6.5
115/1/60 Motor		High	0.6	0.9	1.2	1.9	3.0	1.8	2.6	3.4	13.0
Noise Level at 16-1/2 ft (5m) - dB(A)		Low	45	46	49	54	57	47	49	52	61
		High	52	54	58	63	65	52	55	60	67
Approximate Air Volume	cfm	Low	270	330	560	800	1,100	1,200	1,750	2,200	3,800
		High	400	500	860	1,250	1,650	1,550	2,300	2,850	4,750
	m ³ /hr	Low	459	561	952	1,359	1,869	2,039	2,973	3,738	6,457
		High	680	850	1,461	2,124	2,804	2,634	3,908	4,842	8,071
Supply Air Velocity	fpm	Low	382	443	522	549	578	500	590	613	755
		High	540	672	802	860	866	642	773	793	936
	m/min	Low	116	135	159	167	176	152	180	187	230
		High	165	205	244	262	264	196	236	242	285
Rows of Coils in Heat Exchanger			1	2	2	2	2	2	2	2	2
Water Content	Gallons		1/4	1/2	11/16	7/8	1	1 3/16	1 9/16	1 7/8	2 15/16
	Liters		1.0	2.0	2.6	3.2	3.8	4.6	6.0	7.0	11.1
Approximate Weight	lbs.		37	44	49	55	66	75	88	101	146
	Kg		17	20	22	25	30	34	40	46	66

^A Maximum heating capacity based on steam pressure at 2 psi with entering air temperature of 60°F (16°C) See tables on page 4 for more information.

^B Based on an entering air temperature of 60°F (16°C).

DIMENSIONS

ACCURATE WITHIN ±1/8" (±3mm)

Size	A	B	C	D	E	F	G	Fan Diameter	Ø
18/24	16-7/16 (418)	11-1/8 (282)	18-5/16 (465)	12-5/8 (321)	8-11/16 (220)	5-1/8 (130)	3-15/16 (100)	11-13/16 (300)	3/4
23/33	16-7/16 (418)	11-1/8 (282)	18-5/16 (465)	12-5/8 (321)	8-11/16 (220)	5-1/8 (130)	3-15/16 (100)	11-13/16 (300)	3/4
44/62	18-9/16 (472)	13-1/4 (336)	18-5/16 (465)	14-3/4 (375)	8-11/16 (220)	5-1/8 (130)	3-15/16 (100)	13-3/4 (350)	1 1/4
60/85	20-11/16 (526)	15-3/8 (390)	18-5/16 (465)	16-7/8 (429)	8-11/16 (220)	5-1/8 (130)	3-15/16 (100)	15-3/4 (400)	1 1/4
78/110	22-13/16 (580)	17-1/2 (444)	18-5/16 (465)	19 (483)	8-11/16 (220)	5-1/8 (130)	4-3/4 (120)	17-11/16 (450)	1 1/4
96/120	24-15/16 (634)	19-5/8 (498)	19-3/16 (488)	21-1/8 (537)	8-11/16 (220)	5-1/8 (130)	4-3/4 (120)	17-11/16 (450)	1 1/4
140/175	27-1/16 (688)	21-3/4 (552)	19-3/16 (488)	23-1/4 (591)	8-11/16 (220)	5-1/8 (130)	4-3/4 (120)	19-11/16 (500)	1 1/4
190/238	29-3/16 (742)	23-7/8 (606)	20-3/16 (513)	25-3/8 (645)	8-11/16 (220)	5-1/8 (130)	5-1/8 (130)	21-5/8 (550)	1 1/4
300/350	35-7/16 (900)	30-1/16 (764)	22-5/8 (575)	31-5/8 (803)	8-1/4 (210)	5-1/2 (140)	5-1/8 (130)	25-9/16 (650)	1 1/2

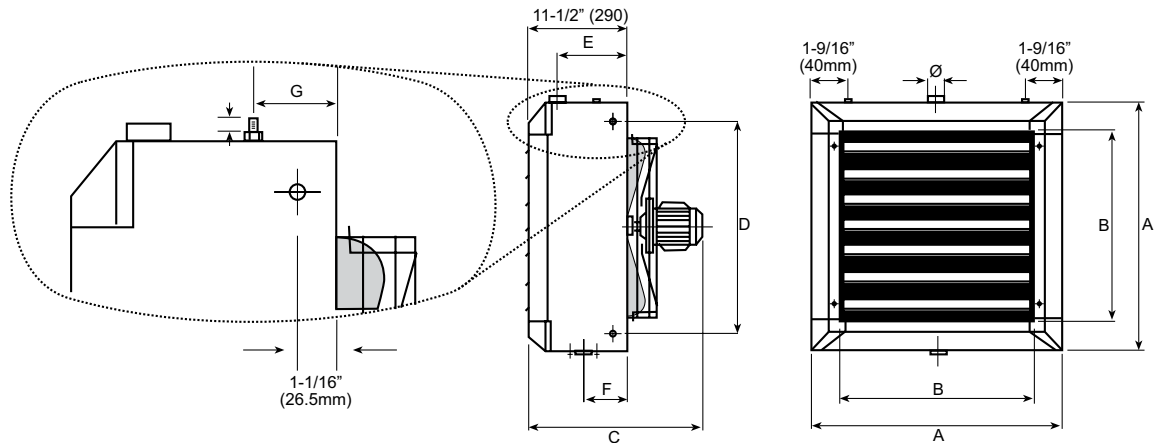



ENGINEERING DATA

HOT WATER CAPACITIES, CALCULATIONS AND CORRECTION FACTORS

Use the following two tables to determine

1. Heating Capacity (MBH)
2. Leaving Air Temperature (LAT)
3. Water Flow in Gallons per Minute (GPM)
4. Water Pressure Drop (WPD) in feet of water

The performances reflected in these tables are based on the following:

- Entering Water Temperature (EWT): 200°F (93°C)
- Water Temperature Drop (WTD): 20° (11°C)
- Entering Air Temperature (EAT): 60° (16°C)

TABLE A - Low Speed Fan Setting

Size	Approx. Fan rpm	MBH Output	Leaving Air Temp. (LAT)		Water Flow		WPD feet of water	Air Volume	
			°F	°C	Gal. per Minute	Liters per Minute		cfm	(m³/hr)
			18/24	1,100	13	104°		40°	1.31
23/33	1,100	17	107°	42°	1.72	6.49	0.01	330	561
44/62	1,100	32	113°	45°	3.23	12.22	0.08	560	952
60/85	1,100	45	112°	44°	4.54	17.18	0.23	800	1,359
78/110	1,100	58	109°	43°	5.85	22.15	0.48	1,100	1,869
96/120	850	72	115°	46°	7.26	27.49	0.95	1,200	2,039
140/175	850	105	115°	46°	10.59	40.09	1.90	1,750	2,973
190/238	850	141	119°	48°	14.22	53.84	4.50	2,200	3,738
300/350	850	230	116°	47°	23.20	87.82	3.30	3,800	6,457

TABLE B - High Speed Fan Setting

Size	Approx. Fan rpm	MBH Output	Leaving Air Temp. (LAT)		Water Flow		WPD feet of water	Air Volume	
			°F	°C	Gal. per Minute	Liters per Minute		cfm	(m³/hr)
			18/24	1,550	19	104°		40°	1.92
23/33	1,600	24	104°	40°	2.42	9.16	0.04	500	850
44/62	1,600	45	108°	42°	4.54	17.18	0.15	860	1,461
60/85	1,600	64	107°	42°	6.46	24.45	0.45	1,250	2,124
78/110	1,600	82	106°	41°	8.27	31.30	0.95	1,650	2,804
96/120	1,080	89	113°	45°	8.98	33.99	1.30	1,550	2,634
140/175	1,080	131	112°	45°	13.22	50.04	2.80	2,300	3,908
190/238	1,080	177	117°	47°	17.86	67.60	7.00	2,850	4,842
300/350	1,080	276	114°	45°	27.84	105.37	4.80	4,750	8,071

TABLE C - Hot Water Correction Factors for EAT and EWT different from cataloged information

Entering Air Temperature (EAT)		Entering Water temperature with 20° Temperature Drop										
		100	120	140	160	180	200	220	240	260	280	300
30°F	-1°C	0.462	0.615	0.769	0.923	1.077	1.231	1.385	1.538	1.692	1.846	2.000
40°F	4°C	0.385	0.538	0.692	0.846	1.000	1.154	1.308	1.462	1.615	1.769	1.923
50°F	10°C	0.308	0.462	0.615	0.769	0.923	1.077	1.231	1.385	1.538	1.692	1.846
60°F	16°C	0.231	0.385	0.538	0.692	0.846	1.000	1.154	1.308	1.462	1.615	1.769
70°F	21°C	0.154	0.308	0.462	0.615	0.769	0.923	1.077	1.231	1.385	1.538	1.692
80°F	27°C	0.077	0.231	0.385	0.538	0.692	0.846	1.000	1.154	1.308	1.462	1.615
90°F	32°C	0.000	0.154	0.308	0.462	0.615	0.769	0.923	1.077	1.231	1.385	1.538
100°F	38°C	0.000	0.077	0.231	0.385	0.538	0.692	0.846	1.000	1.154	1.308	1.462

TABLE D - Hot Water Correction Factors for WTD different from cataloged information

Water Temp. Drop	5°F	10°F	15°F	20°F	25°F	30°F	35°F	40°F	45°F	50°F	55°F	60°F
MBH Correction Factor	1.25	1.15	1.08	1.00	0.95	0.89	0.87	0.84	0.80	0.78	0.74	0.73
GPM Correction Factor	5.00	2.30	1.44	1.00	0.74	0.59	0.49	0.40	0.35	0.30	0.27	0.24

TABLE E - Hot Water Conversion Factors for Water Flow different from cataloged information

% Water Flow*	25%	50%	75%	100%	125%	150%	175%
MBH Correction Factor	0.80	0.89	0.96	1.00	1.04	1.07	1.10

*Calculate % of Water Flow by dividing actual water flow in GPM by the "cataloged" water flow.



ENGINEERING DATA (cont'd)

HOT WATER CAPACITIES, CALCULATIONS AND CORRECTION FACTORS

The heating output of any particular installation is a function of many different factors. It is very seldom that any installation will exactly match the conditions described in the tables on the previous page. For those installations, correction factors must be used to determine heating output and other values.

Below is an example of conditions different from those given in TABLE A and B on the previous page. Following are procedures for determining heating output and other values at conditions other than "cataloged" conditions.

Example:	Unit	Reznor Model 23/33
	Entering Water Temperature (EWT)	160°F
	Entering Air Temperature (EAT)	40°F
	Water Temperature Drop (WTD)	10°F

I.	In TABLE B find the Heating Capacity for "catalog" conditions with High Speed Fan Setting	24,000 BTUH
II.	Determine Heating Capacity for EWT at 160°F and EAT of 40°F	24,000 BUTH x 0.846 = 20,304 BTUH
	Find the correction factor in TABLE C that satisfies the conditions listed. In this instance, it is 0.846. Multiply original BTUH output by the correction factor.	
III.	Determine Heating Capacity for WTD of 10°F	20,304 BTUH x 1.15 = 23,350 BTUH
	Find the correction factor in TABLE D that satisfies the conditions listed. In this instance it is 1.15. Multiply BTUH output by the correction factor.	
IV.	Determine Gallons per Minute (GPM) at 200°F EWT, 60°EAT, but with WTD of 10°F	2.42 GPM
	Find the GPM from TABLE B for "catalog" conditions with High speed Fan Setting	2.42 GPM x 2.30 = 5.57 GPM
	In TABLE D find the GPM Correction Factor for WTD of 10°F. In this case it is 2.30. Multiply original GPM by the correction factor.	
	Note: This formula applies only to units with 200°F EWT and 60°F EAT. For all other applications, use the formula shown (right):	
	Determine GPM for installation described in step III above at 10°F	$23350 \div (500 \times 10^\circ\text{F WTD}) = 4.67 \text{ GPM}$
V.	Determine Water Pressure Drop (WPD) in Feet of Water at 10°F WTD	4.67 GPM
	Find the GPM from step IV above	0.14 FT H ₂ O (as marked)
	On the Heat Exchanger Resistance Chart on page 6, find the WPD at 4.67 GPM on the left side axis. Follow it until it meets the line for Model WS23/33. From that point, follow the line down to the bottom axis to determine the WPD at 176°F mean water temperature.	
	Determine the Correction Factor (K). The above example started with an EWT of 160°F and WTD of 10°F. That would result in water temperature at 150°F as it leaves the heater. Find the mean (average water temperature).	
	Find the Correction Factor (K) for the value nearest 155°F. At 158°F the Correction Factor (K) is 1.05. Multiply 1.05 by the WPD found on the chart 0.14 FT H ₂ O.	
VI.	Determine Heating Capacity for water flow rate of 3.03 GPM	24,000 BUTH
	Determine the Heating Capacity from TABLE B for "catalog" conditions with High Speed Fan Setting	24,000 BTUH x 1.04 = 24,960 BTUH
	Divide actual flow rate in GPM by cataloged flow rate found in TABLE B.	
	In TABLE E find the MBH Correction Factor for a flow rate of 125%. In this case it is 1.04. Multiply original MBH by the correction factor.	
VII.	Determine Leaving Air Temperature (LAT) using the formula shown (right):	LAT = EAT + BTUH ÷ (CFM x 1.085)
	In TABLE B find the Air Volume (cfm) for "cataloged" model and apply it conditions described in Step III above.	$40^\circ\text{F} + (23,350 \text{ BTUH} \div (500 \text{ cfm} \times 1.085)) = 83^\circ\text{F}$

To obtain Pressure Loss Feet of water for other GPM see the graphic data on page 6.



ENGINEERING DATA (cont'd)

HEAT EXCHANGER RESISTANCE CHART

The following table indicates the Water Pressure Drop (WPD) in FT H₂O for each model for a mean water temperature of 176°F (80°C)

- Mean water temperature - °F, °C
- Correction Factor - K

°C	°F	K
50	122	1.15
60	140	1.10
70	158	1.05
80	176	1.00
90	194	0.95
100	212	0.89
110	230	0.83
120	248	0.78
130	266	0.72
140	284	0.67
150	302	0.61

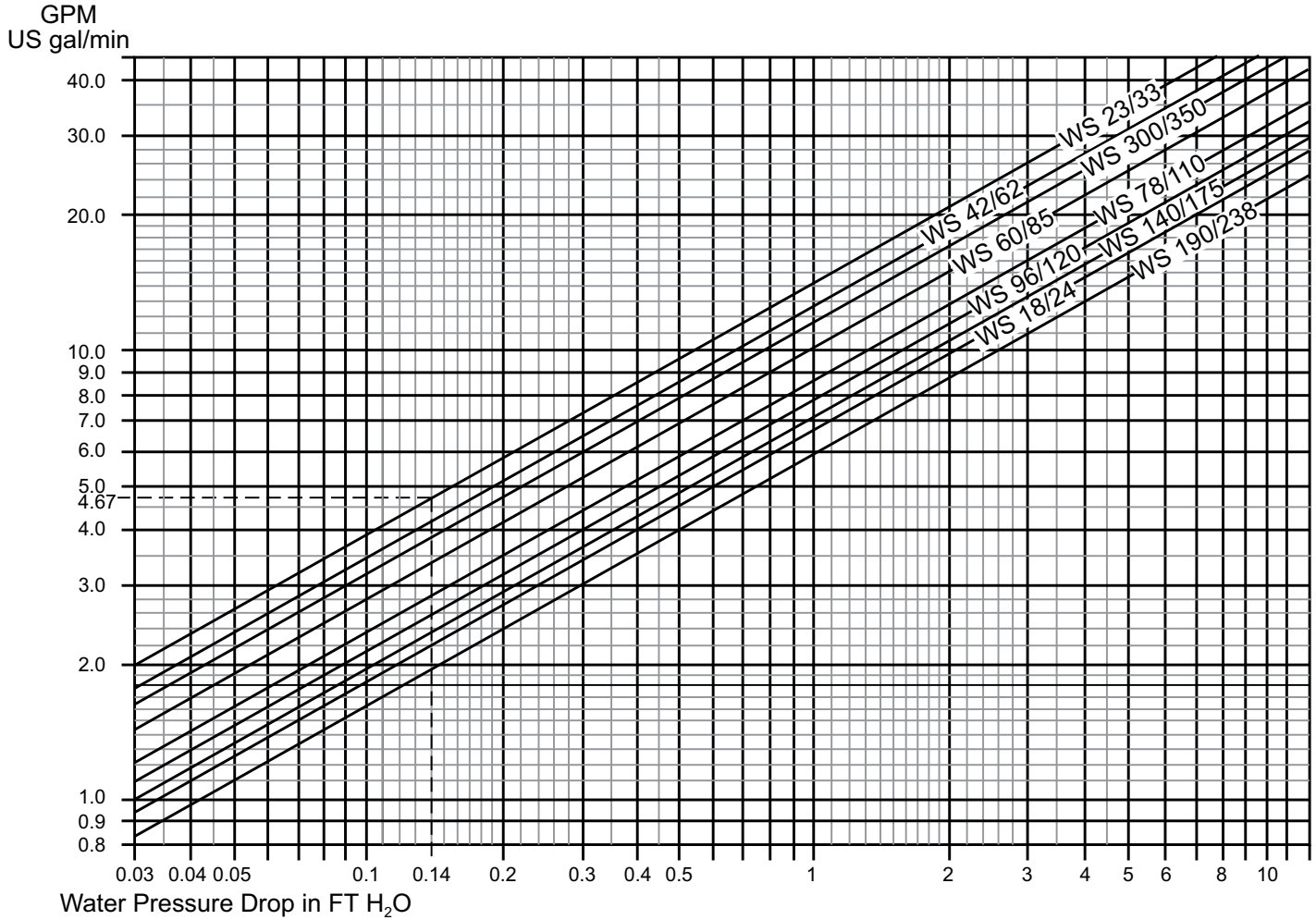

ENGINEERING DATA (cont'd)
TERMS, ABBREVIATIONS AND FORMULAS

Following is a list of terms, abbreviations and formulas to assist in specifying the correct size hydronic heating equipment for a specific application. All terms and abbreviations apply to both steam and hot water heating unless otherwise noted.

- ATR** Air Temperature Rise - The difference between the Entering Air Temperature (EAT) and the Leaving Air Temperature (LAT) due to the amount of heat added.
- BTUH** British Thermal Units per Hour - The common measure of heating output or capacity.
- CFM** Cubic Feet per Minute - The volume of air moved through the heater.
- COND** Condensate - The amount of water that results from removing heat from steam, measured in Pounds per Hour (lb/hr) - steam heat only.
- EAT** Entering Air Temperature - The temperature of the air just before it passes through the heat exchanger.
- EDR** Equivalent Direct Radiation - A measure of heat output measured in square feet - steam heat only.
- EWT** Entering Water Temperature - The temperature of the water as it enters the heat exchanger - hot water heat only.
- FPM** Feet Per Minute - The measure of the velocity of air as it leaves the heater.
- GPM** Gallons Per Minute - The measure of the flow of water that passes through the heat exchanger - hot water heat only.
- L** Latent heat of steam - steam heat only.
- LAT** Leaving Air Temperature - The temperature of the heated air just after it passes through the heat exchanger.
- LWT** Leaving Water Temperature - The temperature of the water as it leaves the heat exchanger - hot water heat only.
- MBH** One thousand BTUH
- PSI** Pounds per Square Inch - The measure of the pressure of steam in pipes - steam heat only.
- RPM** Rotations Per Minute - The number of rotations the fan will make in one minute.
- WPD** Water Pressure Drop - The resistance to the flow of water through a system created by friction between the water and piping - hot water heat only.
- WTD** Water Temperature Drop - The difference between the Entering Water Temperature (EWT) and the Leaving Water Temperature (LWT) due to the amount of heat removed - hot water heat only.

ATR = BTUH ÷ (CFM x 1.08)
LAT = EAT + BTUH ÷ (CFM x 1.08)
GPM = BTUH ÷ (WTD x 500)
WTD = BTUH ÷ (GPM x 500)
COND = BTUH ÷ L
COND = EDR ÷ 4
EDR = BTUH ÷ 240 (at 2 psi only)



ENGINEERING DATA (cont'd)

STEAM CAPACITIES, CALCULATIONS AND CORRECTION FACTORS

Use the following two tables to determine

1. Heating Capacity (MBH)
2. Leaving Air Temperature (LAT)
3. Condensate of water in lbs./hr.
4. Heat output measured in square feet of Equivalent Direct Radiation:

$$1 \text{ ft}^2 \text{ EDR} = 240 \text{ BTUH at 2 psi steam}$$

The performances reflected in these tables are based on the following:

- Steam pressure: 2 Pounds per Square Inch (psi)
- Entering Air Temperature (EAT): 60° (16°C)

TABLE A - Low Speed Fan Setting

Size	Approx. Fan rpm	MBH Output	Leaving Air Temp. (LAT)		Cond. Lbs./hr	Sq.Ft. EDR
			°F	°C		
18/24	1,100	18	121°	50°	19	75
23/33	1,100	23	124°	51°	24	96
44/62	1,100	44	132°	56°	46	183
60/85	1,100	60	129°	54°	62	250
78/110	1,100	78	125°	52°	81	325
96/120	850	96	134°	57°	99	400
140/175	850	140	134°	57°	145	583
190/238	850	190	140°	60°	197	792
300/350	850	300	133°	56°	310	1,250

TABLE B - High Speed Fan Setting

Size	Approx. Fan rpm	MBH Output	Leaving Air Temp. (LAT)		Cond. Lbs./hr	Sq.Ft. EDR
			°F	°C		
18/24	1,550	24	115°	46°	25	100
23/33	1,600	33	121°	49°	34	138
44/62	1,600	62	126°	52°	64	258
60/85	1,600	85	123°	50°	88	354
78/110	1,600	110	121°	50°	114	458
96/120	1,080	120	131°	55°	124	500
140/175	1,080	175	130°	55°	181	729
190/238	1,080	238	137°	58°	246	992
300/350	1,080	350	128°	53°	362	1,458

TABLE C - Steam Correction Factors for Steam Pressure and EAT different from cataloged information

Entering Air Temperature (EAT)		Steam Pressure - psi (saturated)												
		0	2	5	10	15	20	30	40	50	75	100	125	150
30°F	-1°C	1.19	1.24	1.29	1.38	1.44	1.50	1.60	1.68	1.70	1.90	2.02	2.11	2.20
40°F	4°C	1.11	1.16	1.21	1.29	1.34	1.42	1.51	1.60	1.60	1.81	1.93	2.02	2.11
50°F	10°C	1.03	1.08	1.13	1.21	1.28	1.33	1.43	1.51	1.58	1.72	1.84	1.93	2.02
60°F	16°C	0.96	1.00	1.05	1.13	1.19	1.25	1.35	1.43	1.50	1.64	1.75	1.84	1.93
70°F	21°C	0.88	0.93	0.97	1.06	1.12	1.17	1.27	1.35	1.42	1.55	1.66	1.76	1.84
80°F	27°C	0.81	0.85	0.90	0.98	1.04	1.10	1.19	1.27	1.34	1.47	1.58	1.68	1.76
90°F	32°C	0.74	0.78	0.83	0.91	0.97	1.02	1.12	1.19	1.26	1.39	1.50	1.59	1.67
100°F	38°C	0.67	0.71	0.76	0.84	0.89	0.95	1.04	1.12	1.19	1.32	1.42	1.51	1.59

TABLE D - Properties of Saturated Steam

	STEAM PRESSURE (PSIG)												
	1	1	2	4	6	8	10	15	25	50	75	100	125
STEAM PRESSURE (PSIA)	14.7	15.7	16.7	18.7	20.7	22.7	24.7	29.7	39.7	64.7	89.7	114.7	139.7
BOILING POINT OF STEAM °F	212	215.3	218.5	224.4	229.8	234.8	239.4	249.8	266.8	297.7	320.1	337.9	352.9
VOLUME OF 1 LB. OF STEAM CU. FT.	26.79	25.2	23.78	21.4	19.45	17.85	16.49	13.87	10.57	6.68	4.91	3.891	3.225
HEAT OF THE LIQUID BTUH	180	183.3	186.6	192.5	198	203	207.7	218.2	235.6	267.2	290.3	308.8	324.4
L - LATENT HEAT OF STEAM BTUH	970.4	968.2	966.2	962.4	958.8	955.5	952.5	945.5	933.6	911.2	894.2	880	867.8
TOTAL HEAT OF STEAM BTUH	1150.4	1151.6	1152.8	1154.9	1156.3	1158.6	1160.2	1163.7	1169.2	1178.4	1184.4	1188.8	1192.2



ENGINEERING DATA (cont'd)

STEAM CAPACITIES, CALCULATIONS AND CORRECTION FACTORS

The heating output of any particular installation is a function of many different factors. It is very seldom that any installation will exactly match the conditions described in the tables on the previous page. For those installations, correction factors must be used to determine heating output and other values.

Below is an example of conditions different from those given in TABLE A and B on the previous page. Following are procedures for determining heating output and other values at conditions other than "cataloged" conditions.

Example:	Unit	Reznor Model 23/33
	Steam Pressure	10 psi
	Entering Air Temperature (EAT)	40°F

I.	In TABLE B find the Heating Capacity for "catalog" conditions with High Speed Fan Setting	33,000 BTUH
II.	Determine Heating Capacity for steam pressure of 10 psi and EAT of 40°F	33,000 BUTH x 1.290 = 42,570 BTUH
	Find the conversion factor in TABLE C that satisfies the conditions listed. In this instance, it is 1.290. Multiply original BTUH output by the conversion factor.	
III.	Determine Leaving Air Temperature (LAT) using the formula shown (right):	$LAT = EAT + BTUH \div (CFM \times 1.085)$
	In TABLE B find the Air Volume (cfm) for "cataloged" model and apply it conditions described in Step II above.	$40^{\circ}F + (42,570 \text{ BTUH} \div (500 \text{ cfm} \times 1.085)) = 118^{\circ}F$
IV.	Determine the condensate in pounds per hour (lbs/hr).	42,570 BTUH \div 952.5 = 44.7 lbs/hr of condensate
	Divide the heating output by the Latent Heat of steam found in TABLE D at 10psi. In this case it is 952.5.	
V.	Determine the Equivalent Direct Radiation (EDR) in square feet based on conditions in step IV using the formula shown (right):	$EDR = 4 \times \text{condensate (lbs/hr)}$
		$4 \times 44.7 \text{ lbs/hr} = 179 \text{ sq. ft. EDR}$

Size	Fan Motor	Horizontal Discharge				Vertical Discharge			
		Max Mounting Height		Throw		Max Mounting Height		Cover ①	
		H				H			
		ft	m	ft	m	ft	m	ft ²	m ²
18/24	Low Speed	10	3	16	5	10	3	344	32
	High Speed	10	3	23	7	11	3.5	473	44
23/33	Low Speed	10	3	16	5	10	3	366	34
	High Speed	10	3	25	7.5	11	3.5	516	48
44/62	Low Speed	10	3	18	5.5	11	3.5	387	36
	High Speed	11	3.5	26	8	13	4	538	50
60/85	Low Speed	11	3.5	25	7.5	13	4	484	45
	High Speed	13	4	36	11	15	4.5	646	60
78/110	Low Speed	11	3.5	33	10	15	4.5	538	50
	High Speed	13	4	46	14	16	5	753	70
96/120	Low Speed	13	4	33	10	15	4.5	538	50
	High Speed	15	4.5	46	14	16	5	753	70
140/175	Low Speed	15	4.5	39	12	16	5	646	60
	High Speed	16	5	52	16	18	5.5	861	80
190/238	Low Speed	16	5	46	14	18	5.5	968	90
	High Speed	18	5.5	59	18	20	6	1184	110
300/350	Low Speed	18	5.5	66	20	23	7	1399	130
	High Speed	20	6	85	26	30	9	1722	160

① "Cover" is given in square feet (square meters). Example 484 square feet equals an area measuring 22 feet by 22 feet.

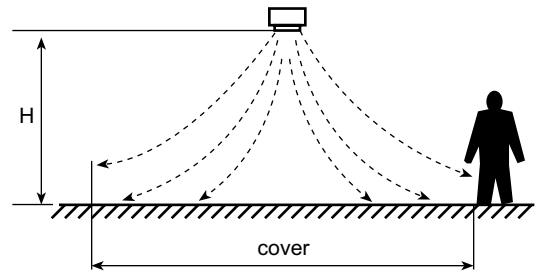
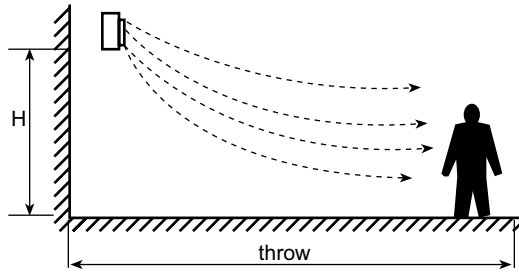

RECOMMENDED INSTALLATION DETAILS FOR PIPING CONNECTIONS

Hot Water Connections

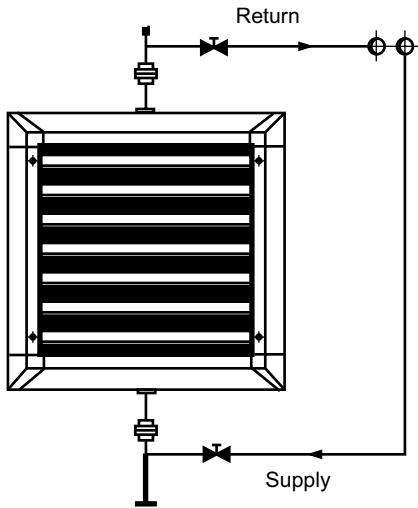

Horizontal Discharge Units

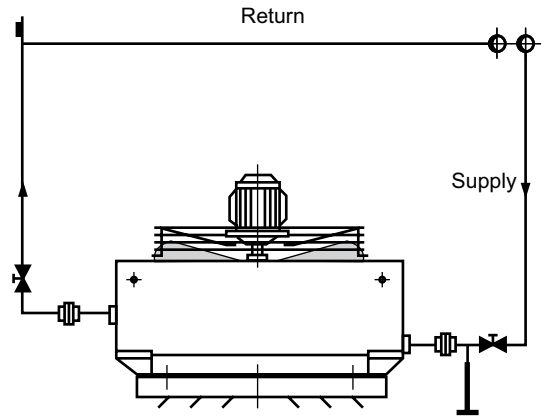

Vertical Discharge Units

Steam Connections

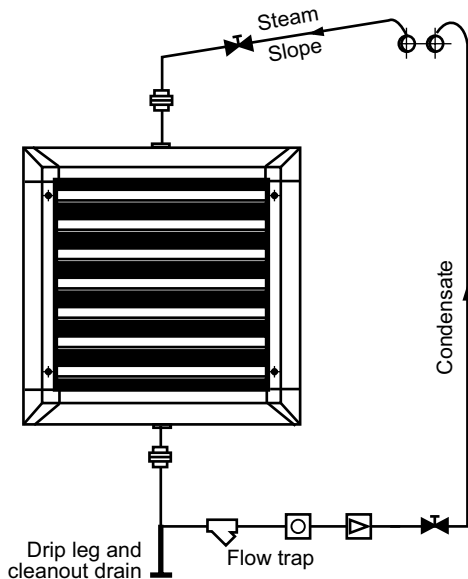

Horizontal Discharge Units

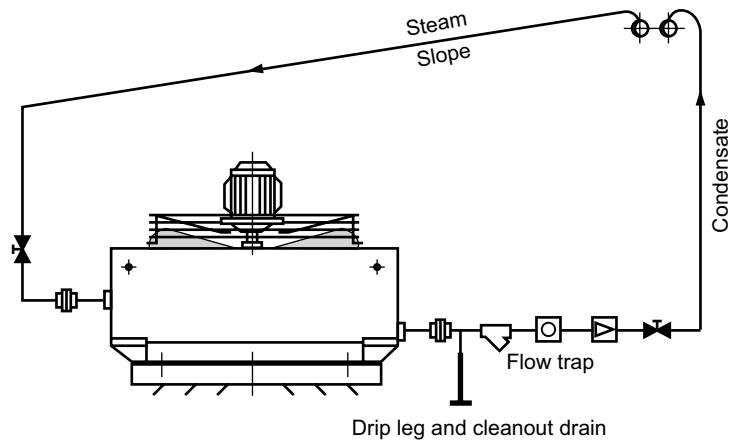

Vertical Discharge Units



CEILING INSTALLATION SUSPENSION PLATE FOR CEILING INSTALLATION

All units are shipped with suspension plates for mounting.

Size	18/24	23/33	44/62	60/85	78/110	96/120	140/175	190/238	300/350
A	12-3/4 (321)	12-3/4 (321)	14-3/4 (375)	16-7/8 (429)	19 (483)	21-1/8 (537)	23-1/4 (591)	25-3/8 (645)	31-5/8 (803)

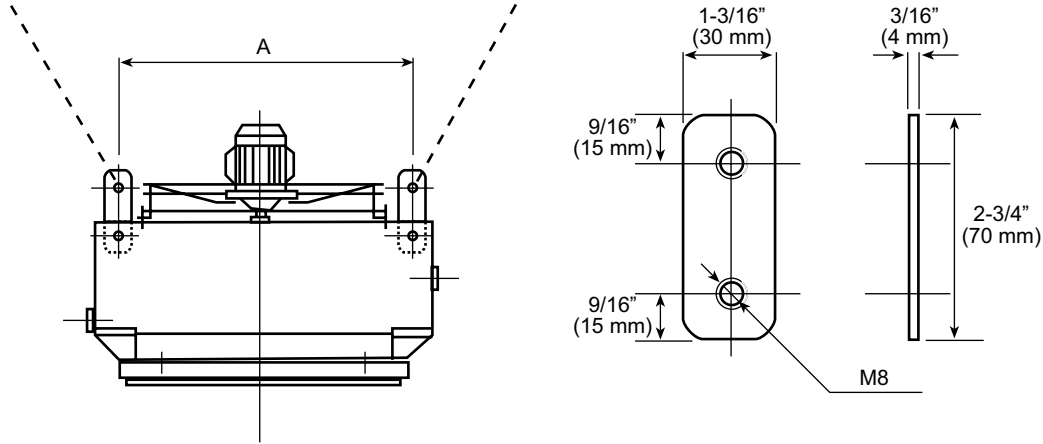

OPTIONAL VERTICAL LOUVERS

Vertical Louvers can be used with units installed for either horizontal or vertical discharge, but they are recommended for vertical discharge units to create a 4 way discharge pattern.

Size	A	B
18/24	12-1/2 (318)	11-1/8 (282)
23/33	12-1/2 (318)	11-1/8 (282)
44/62	14-5/8 (372)	13-1/4 (336)
60/85	16-3/4 (426)	15-3/8 (390)
78/110	18-7/8 (480)	17-1/2 (444)
96/120	21 (534)	19-5/8 (498)
140/175	23-1/8 (588)	21-3/4 (552)
190/238	25-1/4 (642)	23-7/8 (606)
300/350	31-1/2 (800)	30-1/6 (764)

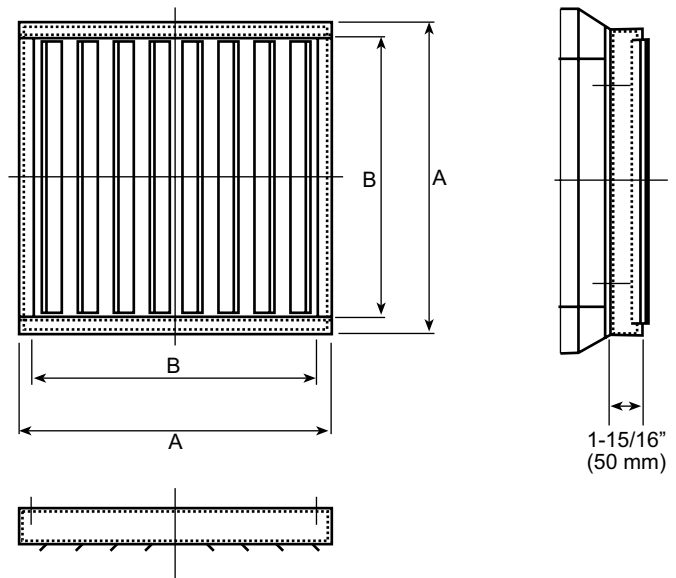

REZNOR® OPTIONAL AIR FLOW INDUCTION OPTIMIZER

Greatly increase the throw of horizontal discharge units.

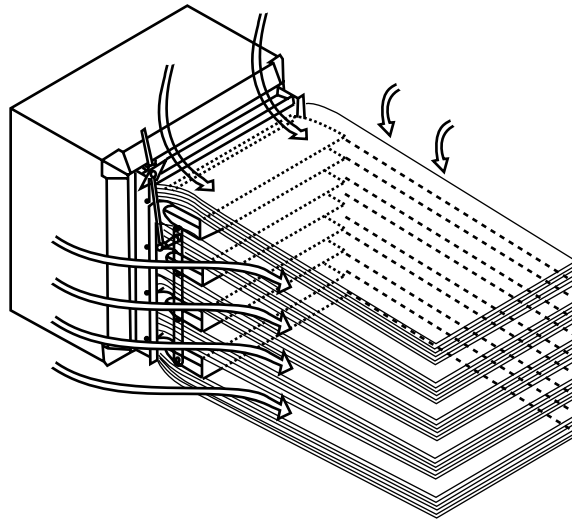

The Air Flow Induction Optimizer increases the throw for Reznor Models WS. This increased flow results in energy savings and better environmental control. This option increases the air speed thanks to the unique shape of the deflecting louvers which create layers of hot air at the unit outlet.

The space created between layers causes air around the front of the unit to be drawn into the air stream and mixed with the heated air. The result is a lower leaving air temperature and a significant increase in the air throw.

Size	A
18/24	12-3/8 (314)
23/33	12-3/8 (314)
44/62	14-1/2 (368)
60/85	16-5/8 (422)
78/110	18-3/4 (476)
96/120	20-7/8 (530)
140/175	23 (584)
190/238	25-1/8 (638)

All dimensions given in inches and (mm).

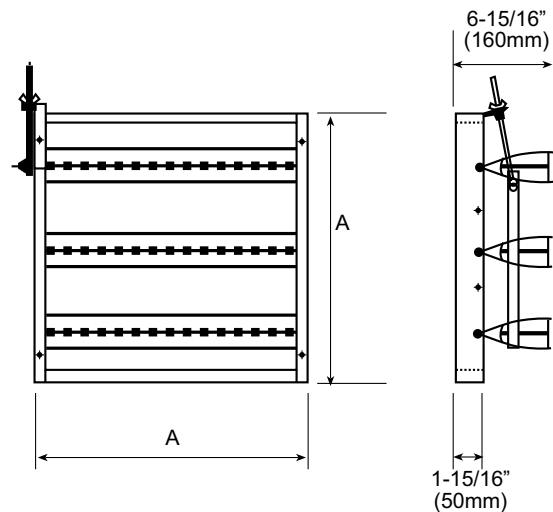



OPTIONAL AIR FLOW INDUCTION OPTIMIZER (cont'd)

Without the Optional Air Flow Induction Optimizer air flow and throw are good.

The leaving air temperature from the units has a decisive influence on hot air stratification and consequently on energy saving: for every 2°F (1°C) increase in temperature there is a 1.5% increase in energy consumption.

The use of the Air Flow Induction Optimizer has the following advantages:

- a) Energy Saving
 - Reduced hot air stratification within the building
 - Reduced operating time of the units with the same ambient temperature

Energy savings vary by region and other variables, but average savings can be between a minimum of 5% and a maximum of 15%. In many applications, payback is within two heating seasons.

- b) Environmental Comfort
 - Increased floor temperature uniformity with greater comfort area
 - Possibility to install smaller and quieter units, due to increase of throw

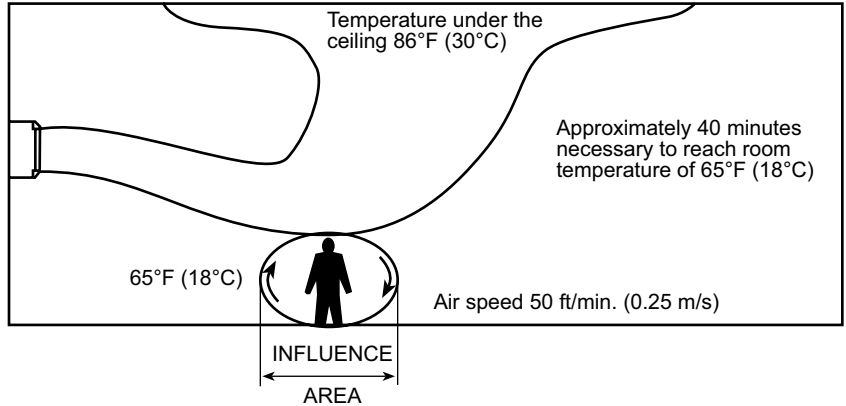

With the Optional Air Flow Induction Optimizer air flow and throw are better.

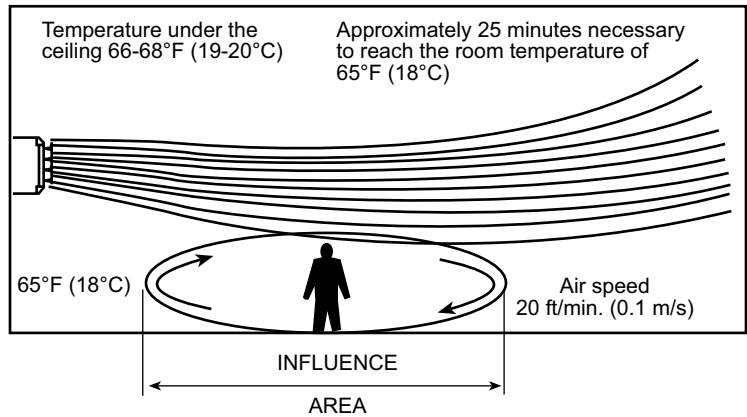

Increase in throw with the Optional Air Flow Induction Optimizer in feet (meters)

Size	Maximum Throw without Optimizer		Maximum Throw with Optimizer	
	Low Speed	High Speed	Low Speed	High Speed
18/24	16 (5)	23 (7)	26 (8)	36 (11)
23/33	16 (5)	25 (7.5)	26 (8)	39 (12)
44/62	18 (5.5)	26 (8)	30 (9)	43 (13)
60/85	25 (7.5)	36 (11)	43 (13)	52 (16)
78/110	33 (10)	46 (14)	49 (15)	62 (19)
96/120	33 (10)	46 (14)	49 (15)	62 (19)
140/175	39 (12)	52 (16)	56 (17)	75 (23)
190/238	46 (14)	59 (18)	62 (19)	79 (24)

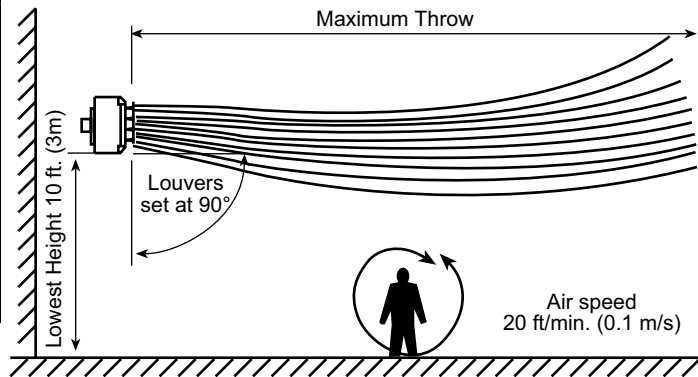

**GENERAL LAYOUT
INSTALLATION SUGGESTIONS**

Suggested layout for horizontal discharge suspended units with no options. Effective throw of the unit can be enhanced with vertical louvers or optional Air Flow Induction Optimizer.

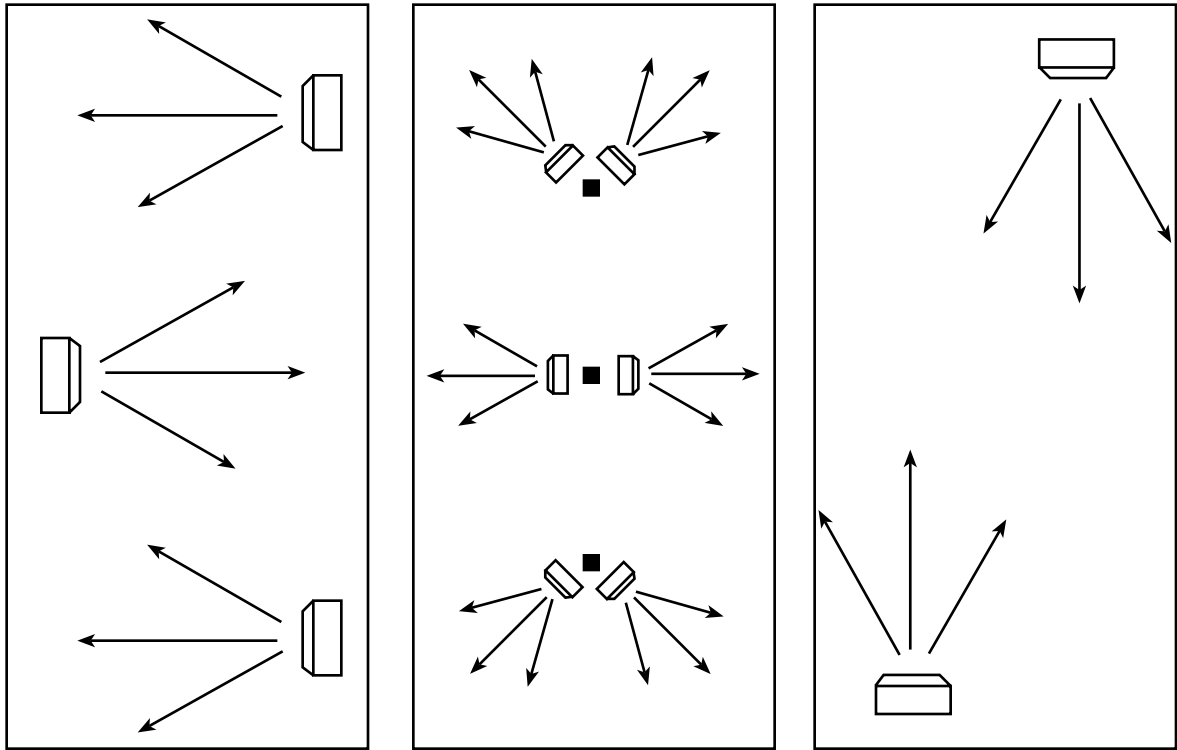

Suggested layout for vertical discharge suspended units with no options. Effective cover of the unit can be enhanced with vertical louvers.

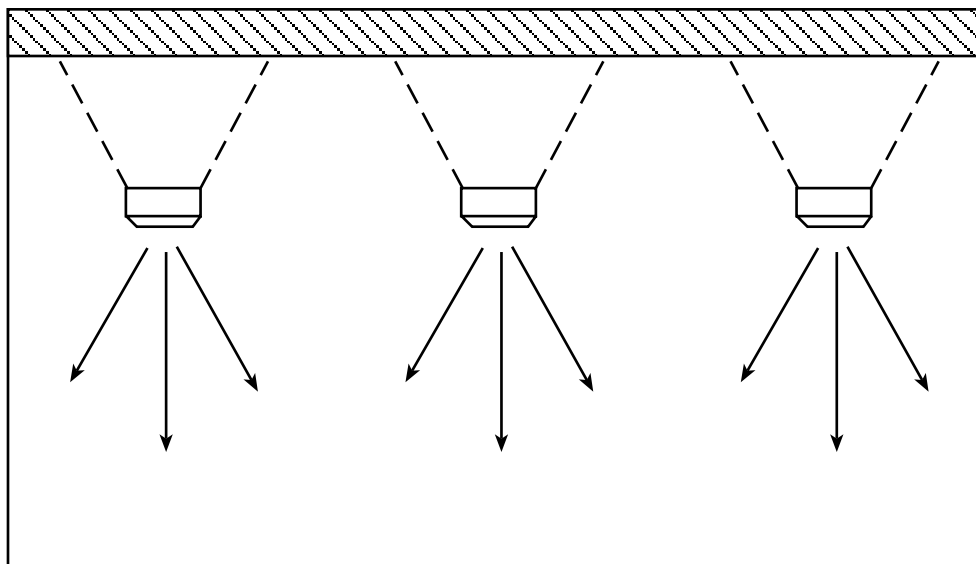

LIMITED PRODUCT WARRANTY

Reznor, LLC warrants to the original owner-user that this Reznor product will be free from defects in material or workmanship. This warranty is limited to twelve (12) months from the date of original installation, whether or not actual use begins on that date, or eighteen (18) months from date of shipment by Reznor, LLC, whichever occurs first.

EXTENDED WARRANTY

(Limited to the following Models, Components, and Applications.)

Model WS — Extended one (1) year non-prorated warranty on the heat exchanger assembly. If leaks or other failure occur within the warranty period, Reznor, LLC will pay up to \$50 for qualified contractor to make necessary repairs. If the heat exchanger cannot be repaired, Reznor, LLC will exchange the damaged unit for a new hydronic heater.

LIMITATIONS AND EXCLUSIONS

Reznor, LLC obligations under this warranty and the sole remedy for its breach are limited to repair, at its manufacturing facility, of any part or parts of its Reznor products which prove to be defective; or, in its sole discretion, replacement of such products. All returns of defective parts or products must include the product model number and serial number, and must be made through an authorized Reznor distributor or arranged through Reznor Customer Service. Authorized returns must be shipped prepaid. Repaired or replacement parts will be shipped by Reznor, LLC F.O.B. shipping point.

1. The warranty provided herein does not cover charges for labor or other costs incurred in the troubleshooting, repair, removal, installation, service or handling of parts or complete products.
2. All claims under the warranty provided herein must be made within ninety (90) days from the date of discovery of the defect. Failure to notify Reznor, LLC of a warranted defect within ninety (90) days of its discovery voids Reznor, LLC obligations hereunder.
3. The warranty provided herein shall be void and of no effect in the event that (a) the product has been operated outside its designed output capacity (heating, cooling, airflow); (b) the product has been subjected to misuse, neglect, accident, improper or inadequate maintenance, corrosive environments, environments containing airborne contaminants (silicone, aluminum oxide, etc.), or excessive thermal shock; (c) unauthorized modifications are made to the product; (d) the product is not installed or operated in compliance with the manufacturer's printed instructions; (e) the product is not installed and operated in compliance with applicable building, mechanical, plumbing and electrical codes; or (f) the serial number of the product has been altered, defaced or removed.
4. The warranty provided herein is for repair or replacement only. Reznor, LLC shall not be liable for any loss, cost, damage, or expense of any kind arising out of a breach of the warranty. Further, Reznor, LLC shall not be liable for any incidental, consequential, exemplary, special, or punitive damages, nor for any loss of revenue, profit or use, arising out of a breach of this warranty or in connection with the sale, maintenance, use, operation or repair of any Reznor product. In no event will Reznor, LLC be liable for any amount greater than the purchase price of a defective product. The disclaimers of liability included in this paragraph 4 shall remain in effect and shall continue to be enforceable in the event that any remedy herein shall fail of its essential purpose.
5. THIS WARRANTY IS THE SOLE AND EXCLUSIVE WARRANTY FOR REZNOR PRODUCTS, AND IS IN LIEU OF ALL OTHER EXPRESS AND IMPLIED WARRANTIES. REZNOR, LLC SPECIFICALLY DISCLAIMS ALL OTHER EXPRESS AND IMPLIED WARRANTIES, INCLUDING, BUT NOT LIMITED TO, ALL IMPLIED WARRANTIES OF MERCHANTABILITY AND FITNESS FOR A PARTICULAR PURPOSE. No person or entity is authorized to bind Reznor, LLC to any other warranty, obligation or liability for any Reznor product. Installation, operation or use of the Reznor product for which this warranty is issued shall constitute acceptance of the terms hereof.

REZNOR®

**Reznor® is your global source for heating,
ventilating and air conditioning equipment.**

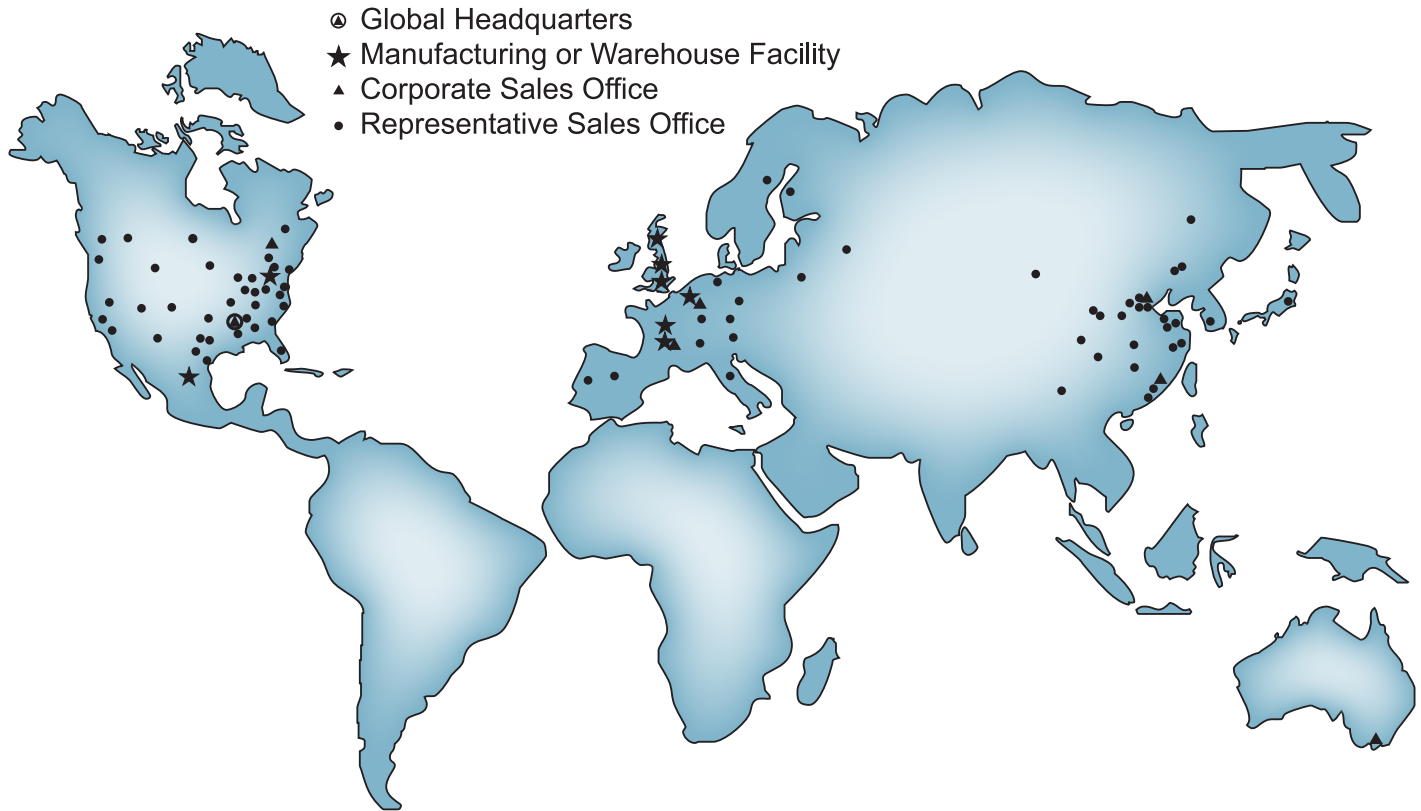

REZNOR®

**For more information on Reznor HVAC Equipment,
contact your local Reznor Representative by calling
800-695-1901.**

**Or, find us on the internet at
www.RezSpec.com**

Reznor is registered in at least the United States. All other marks are the property of their respective organizations.

© 2014 Reznor, LLC. All rights reserved. Printed in U.S.A.

MANUFACTURER OF GAS, OIL, ELECTRIC HEATING, COOLING AND VENTILATING EQUIPMENT

0514 YL POD

Form RZ-NA-C-HU

(Version C.2)