

# CURB HOLD DOWNS FOR CARRIER ROOFTOP UNIT

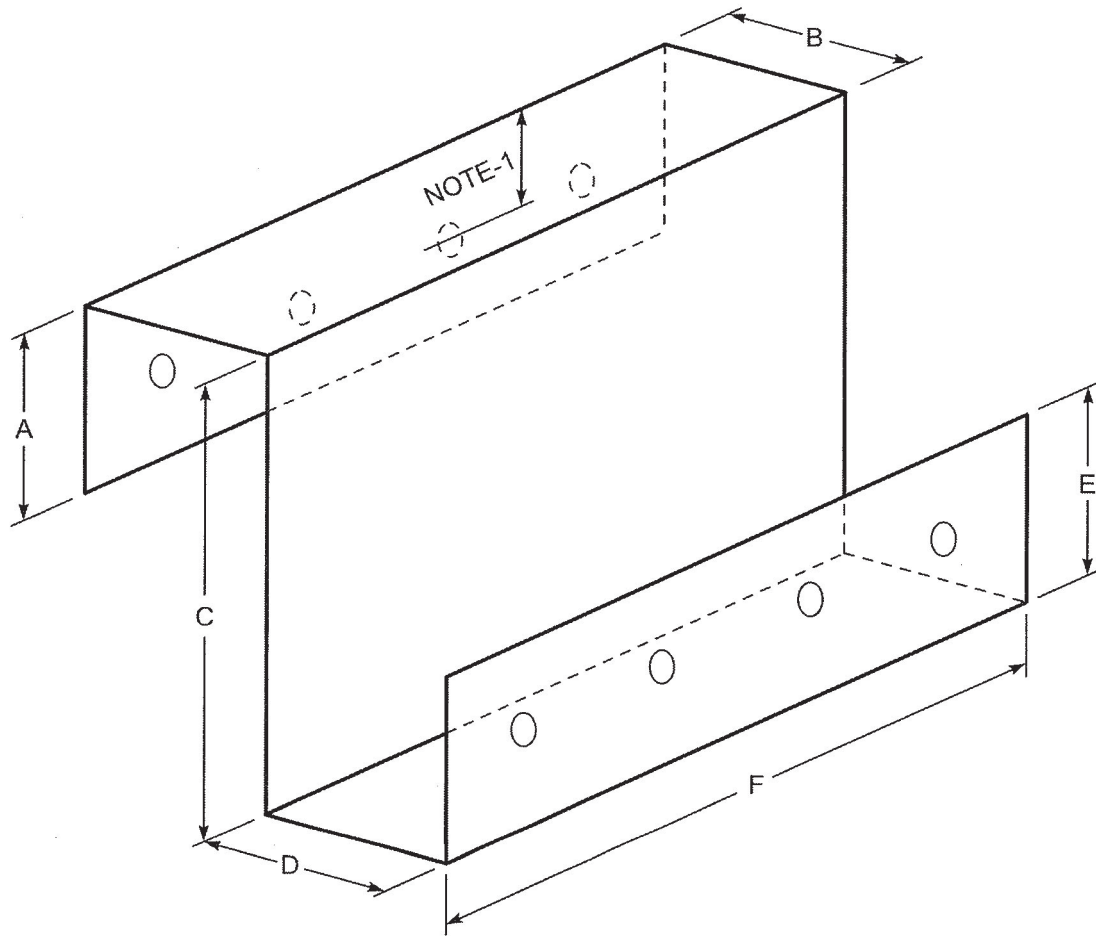

**NOTES:**

1. SCREW CENTERLINE TO BE MINIMUM OF 1 1/4" BELOW TOP
2. 16 GAUGE GALVANIZED STEEL

**INSTALLATION INSTRUCTIONS**

1. PLACE "B" DIMENSION CHANNEL OVER TOP FLANGE OF CURB.
2. ORGANIZE CLIPS SO THAT UNIT BASE RAIL WILL FIT IN "D" DIMENSION SPACE.
3. SECURE CLIPS TO CURB USING FIELD SUPPLIED TEK SCREWS. PLACE THE UNIT ON CURB PER MANUFACTURER SPECIFICATIONS AND SCREW CLIP TO UNIT BASE RAIL WITH TEK SCREWS.

**DIMENSIONAL DATA**

MODEL	PLENUMS INC. MODEL	A	B	C	D	E	F	QTY. REQUIRED
48/50TCA04-07 & 48/50HCA04-06 & 48/50TCQA04-07	CCSRH345	1 3/4"	1 3/4"	4 7/8"	3 1/8"	2"	6"	TBD
48/50TCA08-12/TCD08-14 & 48/50HCA07 48/50HCD08-12 & 50TCQD08-12	CCSRH812	1 3/4"	1 3/4"	4 7/8"	3 1/8"	2"	6"	TBD
		1 3/4"	1 3/4"	4 7/8"	6 1/4"	2"	6"	TBD
48/50 HCD14 & 48/50TCD16	CCSRH816	1 3/4"	1 3/4"	4 7/8"	2 7/8"	2"	6"	TBD
48/50TC-D17/20 & 48/50HC17 48/50TC-D24/28 & 48/50HC20/24	CCTSRH24	1 3/4"	1 3/4"	4 7/8"	3 3/8"	2"	6"	TBD
48/50HC-D28 & 48/50TC-D30	CCTSRH30	1 3/4"	1 3/4"	4 7/8"	3 3/8"	2"	6"	TBD
48/50A020-35	CEJSRH34	1 3/4"	1 3/4"	3"	3 3/8"	2"	6"	TBD



**P.O. BOX 1890 PINELLAS PARK, FL 33780-1890**

**PHONE: 800-237-2275 • FAX: 800-238-1819**

**www.plenums.com • admin@plenums.com**