

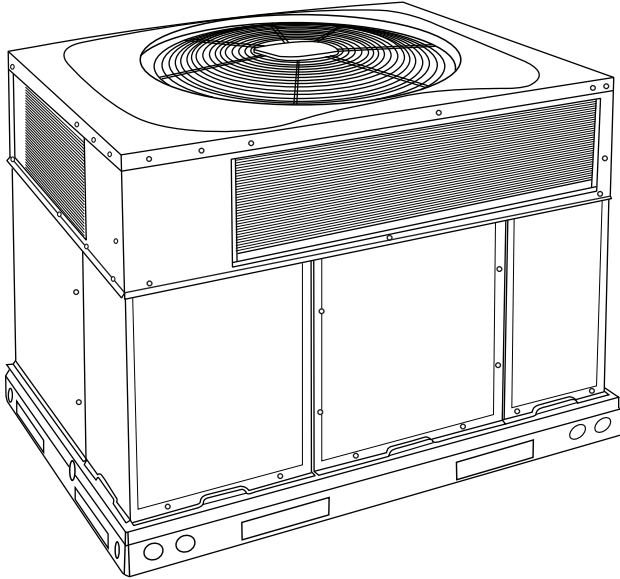

## Product Data



A09183

Fig. 1 - Unit PA4G--A

Single-Packaged Products with Energy-Saving Features and R-410A refrigerant.

- 14.2-14.5 SEER / 12.0 EER
- Factory-Installed TXV
- ECM Motor-Standard
- Low Sound Levels

### FEATURES/BENEFITS

One-piece cooling unit with optional electric heater, low sound levels, easy installation, low maintenance, and dependable performance.

#### Easy Installation

Factory-assembled package is a compact, fully self-contained, electric cooling unit that is prewired, pre-piped, and pre-charged for minimum installation expense. These units are available in a variety of standard cooling sizes with voltage options to meet residential and light commercial requirements. Units are lightweight and install easily on a rooftop or at ground level. The high tech composite base eliminates rust problems associated with ground level applications.

#### Innovative Unit Base Design

On the inside a high-tech composite material will not rust and incorporates a sloped drain pan which improves drainage and helps inhibit mold, algae and bacterial growth. On the outside metal base rails provide added stability as well as easier handling and rigging.

#### Convertible duct configuration

Unit is designed for use in either downflow or horizontal applications. Each unit is converted from horizontal to downflow and includes horizontal duct covers. Downflow operation is provided in the field to allow vertical ductwork connections. The basepan seals on the bottom openings to ensure a positive seal in the vertical airflow mode.

**Efficient operation High-efficiency design** offers SEER (Seasonal Energy Efficiency Ratios) of 14.2 to 14.5. (See page 4.)

#### Durable, dependable components

**Scroll Compressors** are designed for high efficiency. Each compressor is hermetically sealed against contamination to help promote longer life and dependable operation. Each compressor also has vibration isolation to provide quieter operation. All compressors have internal high pressure and overcurrent protection.

**ECM Motor** is standard on all models.

**Direct-drive PSC (Permanent Split Capacitor) condenser-fan motors** are designed to help reduce energy consumption and provide for cooling operation down to 40°F (4.4°C) outdoor temperature. Motormaster® II low ambient kit is available as a field-installed accessory.

**Thermostatic Expansion Valve** - A hard shutoff, balance port TXV maintains a constant superheat at the evaporator exit (cooling cycle) resulting in higher overall system efficiency.

**Refrigerant system** is designed to provide dependability. Liquid filter driers are used to promote clean, unrestricted operation. Each unit leaves the factory with a full refrigerant charge. Refrigerant service connections make checking operating pressures easier.

**High and Low Pressure Switches** provide added reliability for the compressor.

**Indoor and Outdoor coils** are computer-designed for optimum heat transfer and efficiency. The indoor coil is fabricated from copper tube and aluminum fins and is located inside the unit for protection against damage. The outdoor coil is internally mounted on the top tier of the unit.

**Low sound ratings** ensure a quiet indoor and outdoor environment with sound ratings as low as 73dBA. (See Page 4.)

**Easy to service cabinets** provide easy 3 panel accessibility to serviceable components during maintenance and installation. The basepan with integrated drain pan provides easy ground level installation with a mounting pad. A nesting feature ensures a positive basepan to roof curb seal when the unit is roof mounted. A convenient 3/4-in. (19.05 mm) wide perimeter flange makes frame mounting on a rooftop easy.

**Standard horizontal metal duct covers** with insulation come with the unit and cover the horizontal duct openings. These can be left in place if the units are converted to downflow.

**Cabinets** are constructed of heavyduty, phosphated, zinc-coated prepainted steel capable of withstanding 500 hours in salt spray. Interior surfaces of the evaporator/heat exchanger compartment are insulated with cleanable semi-rigid insulation board, which keeps the conditioned air from being affected by the outdoor ambient temperature and provides improved indoor air quality. (Conforms to American Society of Heating, Refrigeration and Air Conditioning Engineers No. 62P.) The sloped drain pan minimizes standing water in the drain. An external drain is provided.

## TABLE OF CONTENTS

FEATURES/BENEFITS .....	1
MODEL NUMBER NOMENCLATURE .....	3
AHRI CAPACITIES .....	4
PHYSICAL DATA .....	5
OPTIONS AND ACCESSORIES .....	6
BASE UNIT DIMENSIONS .....	8-9
ROOF CURB ACCESSORY .....	10
SELECTION PROCEDURE .....	11
PERFORMANCE DATA .....	12-24
TYPICAL PIPING AND WIRING .....	25
APPLICATION DATA .....	26
ELECTRICAL DATA .....	27
TYPICAL WIRING SCHEMATICS .....	29-34
CONTROLS .....	35
GUIDE SPECIFICATIONS .....	36

# MODEL NUMBER NOMENCLATURE

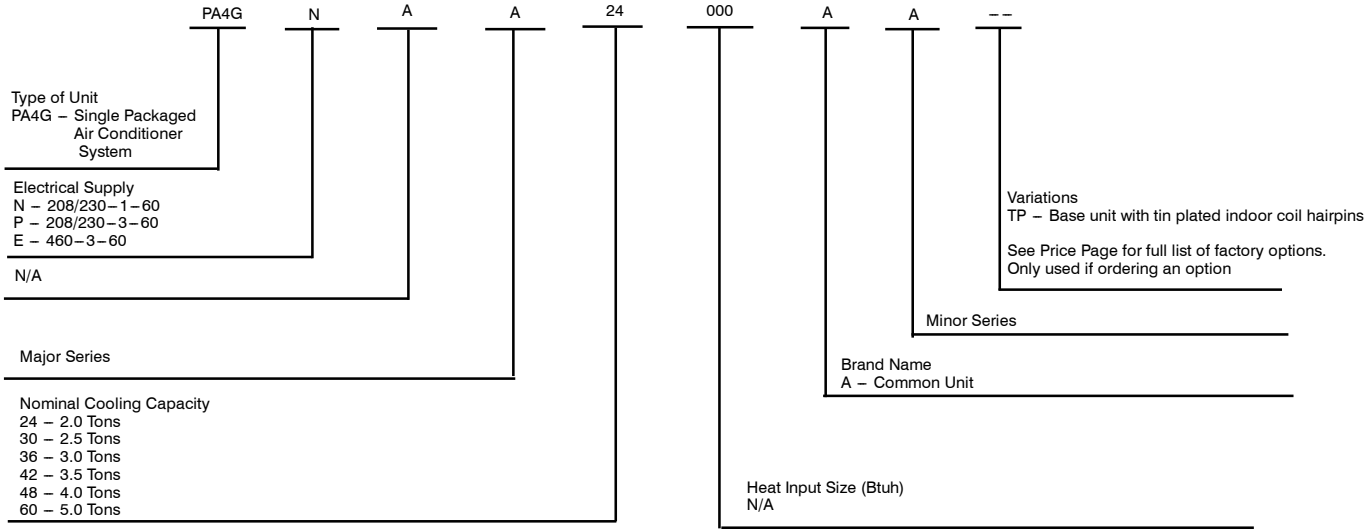

**PA4G**



Use of the AHRI Certified TM Mark indicates a manufacturer's participation in the program. For verification of certification for individual products, go to [www.ahridirectory.org](http://www.ahridirectory.org).



# AHRI\* CAPACITIES

## Cooling Capacities and Efficiencies

UNIT SIZE	NOMINAL TONS	STANDARD CFM	COOLING CAPACITY	EER	SEER
24	2	800	23600	12.0	14.5
30	2.5	1000	28600	12.0	14.5
36	3	1200	34200	12.0	14.5
42	3.5	1400	41000	12.0	14.5
48	4	1600	47000	12.0	14.2
60	5	1750	57000	12.0	14.2

**LEGEND**

**dB**—Sound Levels (decibels)

**db**—Dry Bulb

**SEER**—Seasonal Energy Efficiency Ratio

**wb**—Wet Bulb

**COP**—Coefficient of Performance

\* Air Conditioning, Heating & Refrigeration Institute.

\*\*At "A" conditions—80°F (26.7°C) indoor db/67°F (19.4°C) indoor wb & 95°F (35°C) outdoor db.

† Rated in accordance with U.S. Government DOE Department of Energy) test procedures and/or AHRI Standards 210/240.

**Notes:**

1. Ratings are net values, reflecting the effects of circulating fan heat.

Ratings are based on:

**Cooling Standard:** 80°F (26.7°C) db, 67°F wb (19.4°C) indoor entering—air temperature and 95°F db (35°C) outdoor entering—air temperature.

2. Before purchasing this appliance, read important energy cost and efficiency information available from your retailer.

PA4G

## A-WEIGHTED SOUND POWER LEVEL (dBA)

UNIT SIZE	SOUND RATING	TYPICAL OCTAVE BAND SPECTRUM (without tone adjustment)						
		125	250	500	1000	2000	4000	8000
24	76	58.0	65.5	71.5	71.0	65.5	60.5	53.0
30	73	62.0	64.0	67.5	67.5	65.0	60.0	54.5
36	76	64.5	66.5	70.0	70.0	67.5	61.0	54.0
42	77	70.5	68.0	70.5	70.5	68.0	62.5	58.0
48	77	71.5	65.0	71.0	67.5	67.5	63.0	57.5
60	77	73.5	65.5	68.5	67.5	66.5	62.0	58.0

NOTE: Tested in accordance with AHRI Standard 270—1995 (not listed in AHRI).

## PHYSICAL DATA

UNIT SIZE	24	30	36	42	48	60
<b>NOMINAL CAPACITY (ton)</b>	2	2-1/2	3	3-1/2	4	5
<b>SHIPPING WEIGHT* lb.</b>	295	307	365	421	439	467
<b>SHIPPING WEIGHT* (kg)</b>	134	139	166	191	199	212
<b>COMPRESSORS</b>	Scroll					
Quantity	1					
<b>REFRIGERANT (R-410A)</b>						
Quantity lb	6.0	5.6	9.5	8.8	9.5	12.3
Quantity (kg)	2.7	2.5	4.3	4.0	4.3	5.6
<b>REFRIGERANT METERING DEVICE</b>	TXV					
<b>OUTDOOR COIL</b>						
Rows...Fins/in.	1...21	1...21	2...21	2...21	2...21	2...21
Face Area (sq ft)	11.9	13.6	15.4	13.6	17.5	21.4
<b>OUTDOOR FAN</b>						
Nominal Cfm	2500	2700	2800	3000	3200	3600
Diameter in.	24	24	24	26	26	26
Diameter (mm)	609.6	609.6	609.6	660.4	660.4	660.4
Motor Hp (Rpm)	1/10 (810)	1/10 (810)	1/5 (810)	1/5 (810)	1/5 (810)	1/5 (810)
<b>INDOOR COIL</b>						
Rows...Fins/in.	3...17	3...17	3...17	3...17	3...17	3...17
Face Area (sq ft)	3.7	3.7	3.7	4.7	4.7	5.7
<b>INDOOR BLOWER</b>						
Nominal Cooling Airflow (Cfm)	800	1000	1200	1400	1600	1750
Size in.	10x10	10x10	11x10	11x10	11x10	11x10
Size (mm.)	254x254	254x254	279.4x254	279.4x254	279.4x254	279.4x254
Motor HP (RPM)	1/2 (1050)	1/2 (1050)	3/4 (1000)	3/4 (1075)	1.0 (1075)	1.0 (1040)
<b>HIGH - PRESSURE SWITCH (psig) Cut-out Reset (Auto)</b>	650 +/- 15 420 +/- 25					
<b>LOSS-OF-CHARGE / LOW-PRES-SURE SWITCH (Liquid Line) (psig) cut-out Reset (auto)</b>	20 +/- 5 45 +/- 10					
<b>RETURN-AIR FILTERS†‡</b>						
Throwaway Size in.	20x20x1	20x24x1	24x30x1	24x36x1		
Throwaway Size (mm)	508x508x25	508x610x25	610x762x25	610x914x25		

\*For 460 volt units add 14 lb (6.35 kg) to the shipping weight.

† Required filter sizes shown are based on the larger of the AHRI (Air Conditioning, Heating and Refrigeration Institute) rated cooling airflow or the heating airflow velocity of 300 ft/minute for throwaway type or 450 ft/minute for high-capacity type. Air filter pressure drop for non-standard filters must not exceed 0.08 in. W.C.

‡ If using accessory filter rack refer to the filter rack installation instructions for correct filter sizes and quantity.

PA4G

## Electric Heat Pressure Drop Tables (IN. W.C.)

### Small Cabinet: 24-36

STATIC	CFM											
	500	600	700	800	900	1000	1100	1200	1300	1400	1500	1600
<b>5 kW</b>	0.00	0.00	0.00	0.00	0.00	0.00	0.00	0.00	0.02	0.04	0.06	0.07
<b>10 kW</b>	0.00	0.00	0.00	0.00	0.00	0.02	0.04	0.06	0.07	0.09	0.10	0.11
<b>15 kW</b>	0.00	0.00	0.00	0.02	0.04	0.06	0.08	0.10	0.12	0.14	0.16	0.18
<b>20 kW</b>	0.00	0.00	0.02	0.04	0.06	0.08	0.09	0.11	0.13	0.15	0.17	0.19

### Large Cabinet: 42-60

STATIC	CFM														
	1100	1200	1300	1400	1500	1600	1700	1800	1900	2000	2100	2200	2300	2400	2500
<b>5 kW</b>	0.00	0.00	0.00	0.01	0.02	0.03	0.04	0.05	0.06	0.07	0.08	0.09	0.10	0.11	0.12
<b>10 kW</b>	0.00	0.00	0.01	0.02	0.03	0.04	0.05	0.06	0.07	0.08	0.09	0.10	0.11	0.12	0.13
<b>15 kW</b>	0.00	0.02	0.03	0.04	0.05	0.06	0.07	0.08	0.09	0.10	0.11	0.12	0.13	0.14	0.15
<b>20 kW</b>	0.02	0.03	0.04	0.05	0.06	0.07	0.08	0.09	0.10	0.11	0.12	0.13	0.14	0.15	0.16

## OPTIONS AND ACCESSORIES

ITEM	DESCRIPTION	FACTORY INSTALLED OPTION	FIELD INSTALLED ACCESSORY
Coil Options	Base unit with tin plated indoor coil hairpins	X	
Compressor Start Kit	Compressor Start Kit assists compressor start-up by providing additional starting torque on single phase units only.		X
Corporate Thermostats	Thermostats provide control for the system heating and cooling functions.		X
Crankcase Heater	Crankcase Heater provides anti-floodback protection for low-load cooling applications.		X*
Economizer	Horizontal Economizer with solid state controls and barometric relief dampers includes filter racks and provide outdoor air during cooling and reduce compressor operation.		X
	Vertical Economizer with solid state controls and barometric relief dampers includes filter racks and provide outdoor air during cooling and reduce compressor operation.		X
Electric Heaters	Electric Heat Supplement		X
Filter Rack	Filter Rack features easy installation, serviceability, and high-filtering performance for vertical applications. Includes 1-in. filter.		X
Flat Roof Curbs	Flat Roof Curbs in both 11-in (279 mm) and 14-in. (356 mm) sizes are available for roof mounted applications.		X
Low Ambient Kit	Low Ambient Kit (Motormaster II Control) allows the use of mechanical cooling down to outdoor temperatures as low as 0°F (-18°C) when properly installed.		X
Manual Outside Air Damper	Manual Outside Air Damper includes hood and filter rack with adjustable damper blade for up to 25% outdoor air.		X
Square-to-Round Duct Transition Kit	Square-to-Round Duct Transition Kit enable 24-48 size units to be fitted to 14 in (356 mm) round ductwork.		X
Time Guard II	Automatically prevents the compressor from restarting for at least 4 minutes and 45 seconds after shutdown of the compressor. Not required when a corporate programmable thermostat is applied or with a RTU-MP control.		X
Dual Point Electric Heaters	Allows you to power the electric heater and unit contactor separately by having two individual field power supply circuits connected respectively.		X

\*Refer to Price Page for application detail.

## Electric Heaters

CATALOG ORDERING NO.	NOMINAL CAPACITY (kW)	FUSE QTY	USED WITH SIZES					
			24	30	36	42	48	60
<b>ELECTRIC HEATERS (208/230 — SINGLE PHASE — 60 Hz)</b>								
CPHEATER052A0*	5.0	—	X	X	X	X	X	X
CPHEATER064A0*	5.0	4	X	X	X	X	X	X
CPHEATER069A0*	7.2	—	X	X	X	X	X	X
CPHEATER070A0*	7.2	4	X	X	X	X	X	X
CPHEATER065A0*	10.0	—	X	X	X	X		
CPHEATER050A0*	10.0	4	X	X	X	X	X	X
CPHEATER051A0*	15.0	4		X	X	X		
CPHEATER066A0*	15.0	6		X	X	X	X	X
CPHEATER053A0*	20.0	6				X		
CPHEATER054A0*	20.0	6				X	X	X
<b>ELECTRIC HEATERS (208/230 — THREE PHASE — 60 Hz)</b>								
CPHEATER055A0*	5.0	—		X	X	X	X	X
CPHEATER056A0*	10.0	—		X	X	X	X	X
CPHEATER068A0*	10.0	6		X	X	X	X	X
CPHEATER057A0*	15.0	—		X	X	X	X	X
CPHEATER058A0*	20.0	6		X	X	X	X	X
CPHEATER059A0*	20.0	6				X	X	X
<b>ELECTRIC HEATERS (460 — THREE PHASE — 60 Hz)</b>								
CPHEATER061A0*	10.0	—			X	X	X	X
CPHEATER062A0*	15.0	—			X	X	X	X
CPHEATER063A0*	20.0	—				X	X	X

**NOTE:** Electric heaters are rated at 240v. Refer to Multiplication Factors table for other voltages.

X = Approved combinations.

## Minimum Airflow for Safe Electric Heater Operation (CFM)

SIZE	24	30	36	42	48	60
Cfm	800	1000	1200	1400	1600	1750

# ECONOMIZER

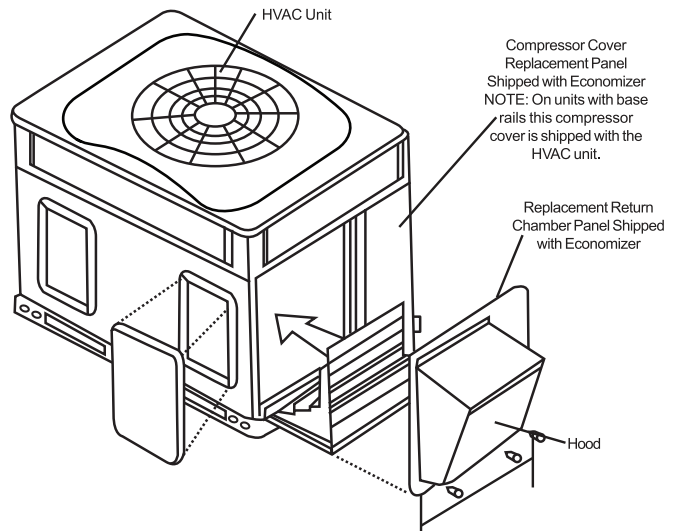
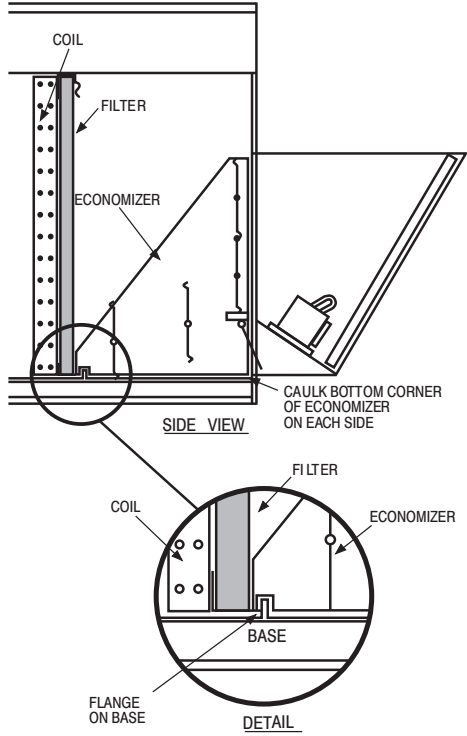

Vertical Economizer

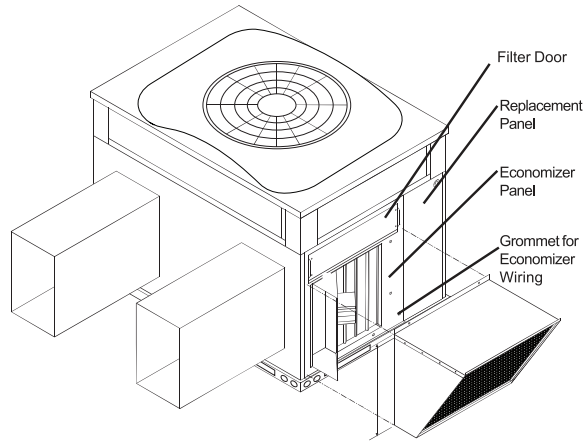

Horizontal Economizer

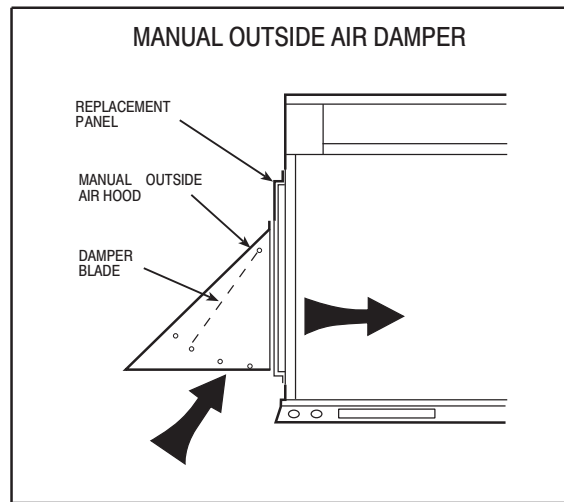
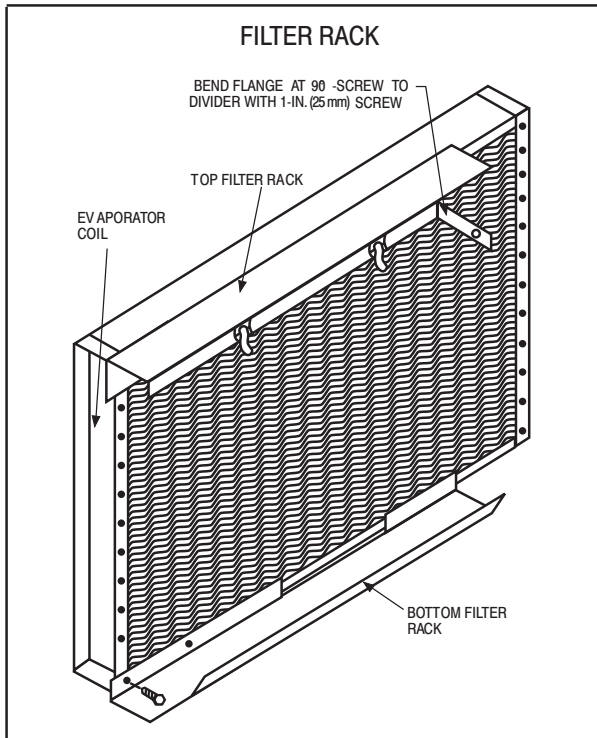

A09421

PA4G

# UNIT DIMENSIONS - 24-36

**PA4G**

UNIT	ELECTRICAL CHARACTERISTICS	UNIT WT.		CENTER OF GRAVITY IN/MM			
		LB	KG	"A"	X	Y	Z
PA4GMA24000AA	208/230-1-60	272	123.3	42-1/8 [1070]	20-1/2 [520.7]	15-3/4 [400.1]	16-1/2 [419.1]
PA4G(N,P)AA36000AA	208/230-1,208/230-3-60	277	125.5	44-1/8 [1121]	20-1/2 [520.7]	15-3/4 [400.1]	16-13/16 [427.0]
PA4G(N,P)AA36000AA	208/230-1,208/230-3-60	283	128.3	46-1/8 [1172]	20-1/2 [520.7]	15-3/4 [400.1]	17 [431.8]
PA4GEAA36000AA	460-3-60	297	134.6	46-1/8 [1172]	20-1/2 [520.7]	15-3/4 [400.1]	17 [431.8]

UNITS	VOLTAGE	CORNER WEIGHT LB/KG		
		"1"	"2"	"3"
PA4GMA24000AA	208/230	54.4 [24.7]	43.5 [19.7]	65.2 [29.6]
PA4G(N,P)AA36000AA	208/230	55.4 [25.1]	44.3 [20.1]	66.4 [30.2]
PA4G(N,P)AA36000AA	208/230	56.6 [25.7]	45.2 [20.5]	67.9 [30.8]
PA4GEAA36000AA	460	56.6 [25.7]	45.2 [20.5]	67.9 [30.8]

NOTE: ALL TABLE DATA RELEVANT FOR ALL FACTORY INSTALLED OPTIONS EXCEPT ECONOMIZER

**REQUIRED CLEARANCES TO COMBUSTIBLE MATL.**

INCHES (MM)

TOP OF UNIT.....14 [355.6]  
 DUCT SIDE OF UNIT.....2 [50.8]  
 SIDE OPPOSITE DUCTS.....14 [355.6]  
 BOTTOM OF UNIT.....0 [0.0]  
 ELECTRICAL PANEL.....36 [914.4]

**NEC. REQUIRED CLEARANCES**

INCHES (MM)

BETWEEN UNITS: POWER ENTRY SIDE.....42 [1066.8]  
 UNIT AND UNGROUNDED SURFACES, POWER ENTRY SIDE.....42 [1066.8]  
 UNIT AND BLOCK OR CONCRETE WALLS AND OTHER GROUNDED SURFACES, POWER ENTRY SIDE.....42 [1066.8]

**REQUIRED CLEARANCE FOR OPERATION AND SERVICING**

INCHES (MM)

EVAP. COIL ACCESS SIDE.....56 [1414.4]  
 POWER ENTRY SIDE.....42 [1066.8]  
 (EXCEPT FOR NEC REQUIREMENTS)  
 UNIT TOP (NEC REQUIREMENTS).....48 [1219.2]  
 SIDE OPPOSITE DUCTS.....36 [914.0]  
 DUCT PANEL.....12 [304.8]

\*MINIMUM DISTANCES-IF UNIT IS PLACED LESS THAN 12 [304.8] FROM WALL SYSTEM, THEN SYSTEM PERFORMANCE MAYBE COMPROMISED.

DIMENSIONS IN [ ] ARE IN MILLIMETERS

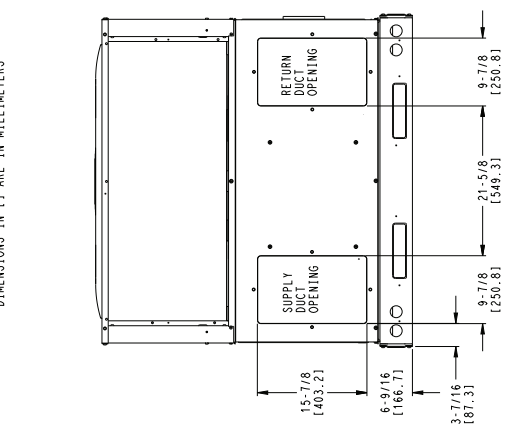
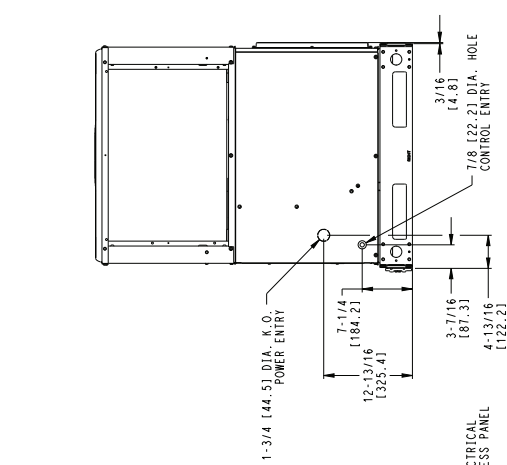
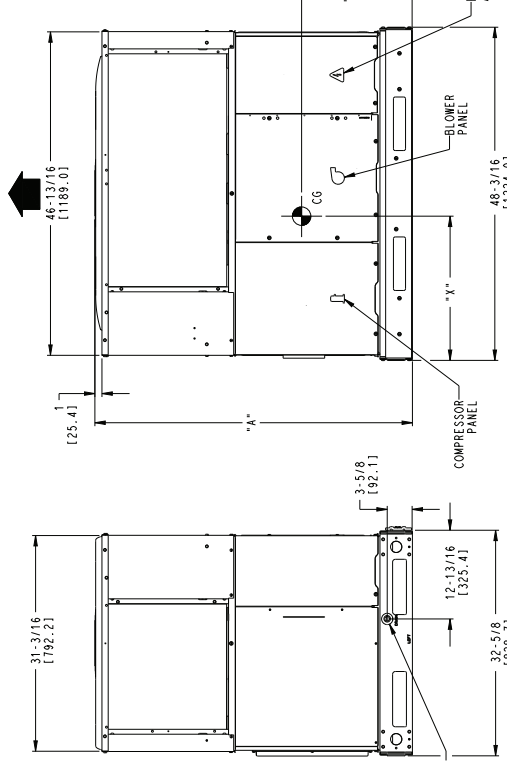
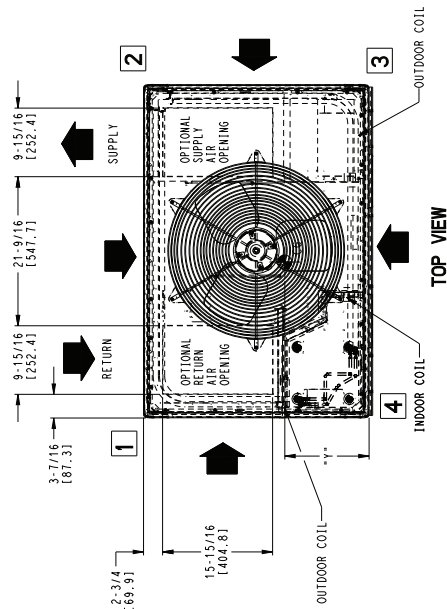

**FRONT VIEW**

**RIGHT SIDE VIEW**

**REAR VIEW**

REV -  
50VL500495



# UNIT DIMENSIONS - 42-60

UNIT	ELECTRICAL CHARACTERISTICS	UNIT WT.				UNIT HEIGHT				CENTER OF GRAVITY IN/MM				
		LB	KG	"A"	"B"	"A"	"B"	X	Y	Z	"A"	"B"	X	Y
PA4G(N, P)AA42000AA	208/230-1, 208/230-3-60	369	167.5	44-3/4	1137	44-3/4	1137	44-3/4	1137	17-1/2	444.5	17-1/8	435.0	
PA4GEAA42000AA	460-3-60	383	173.8	44-3/4	1137	44-3/4	1137	44-3/4	1137	17-1/2	444.5	17-1/8	435.0	
PA4G(N, P)AA48000AA	208/230-1, 208/230-3-60	375	170.2	48-3/4	1238	46-3/4	1187	46-3/4	1187	17-1/2	444.5	17-3/8	441.3	
PA4GEAA48000AA	460-3-60	389	176.6	48-3/4	1238	46-3/4	1187	46-3/4	1187	17-1/2	444.5	17-3/8	441.3	
PA4G(N, P)AA60000AA	208/230-1, 208/230-3-60	397	180.2	52-3/4	1340	46-3/4	1187	46-3/4	1187	17-1/2	444.5	17-5/8	447.7	
PA4GEAA60000AA	460-3-60	411	186.5	52-3/4	1340	46-3/4	1187	46-3/4	1187	17-1/2	444.5	17-5/8	447.7	

UNITS	VOLTAGE	CORNER WEIGHT LB/KG							
		"1"	"2"	"3"	"4"				
PA4G(N, P)AA42000AA	208/230	73.8	33.5	59.1	26.8	88.6	40.2	147.7	67.1
PA4GEAA42000AA	460	73.8	33.5	59.1	26.8	88.6	44.3	152.7	69.3
PA4G(N, P)AA48000AA	208/230	75.0	34.1	60.0	27.3	90.1	40.9	150.1	68.1
PA4GEAA48000AA	460	75.0	34.1	60.0	27.3	99.1	45.0	155.1	70.4
PA4G(N, P)AA60000AA	208/230	79.4	36.1	63.6	28.9	95.3	43.3	158.9	72.1
PA4GEAA60000AA	460	79.4	36.1	63.6	28.9	104.3	47.4	163.9	74.4

NOTE: ALL TABLE DATA RELEVANT FOR ALL FACTORY INSTALLED OPTIONS EXCEPT ECONOMIZER

	INCHES [MM]
REQUIRED CLEARANCES TO COMBUSTIBLE MATL.	
TOP OF UNIT.....	14 [355.6]
DUCT SIDE OF UNIT.....	12 [304.8]
SIDE OPPOSITE DUCTS.....	14 [355.6]
BOTTOM OF UNIT.....	10 [254.0]
ELECTRICAL PANEL.....	36 [914.4]
NEC. REQUIRED CLEARANCES.	
BETWEEN UNITS, POWER ENTRY SIDE.....	32 [812.8]
UNIT AND UNGROUNDED SURFACES, POWER ENTRY SIDE.....	36 [914.4]
UNIT AND BLOCK OR CONCRETE WALLS AND OTHER GROUNDED SURFACES, POWER ENTRY SIDE.....	42 [1066.8]
REQUIRED CLEARANCE FOR OPERATION AND SERVICING	
EVAP. COIL, ACCESS SIDE.....	35 [889.0]
POWER ENTRY SIDE.....	35 [889.0]
(EXCEPT FOR NEC REQUIREMENTS)	42 [1066.8]
UNIT TOP OPPOSITE DUCTS.....	48 [1219.2]
SIDE OPPOSITE DUCTS.....	38 [965.2]
DUCT PANEL.....	12 [304.8]

\*MINIMUM DISTANCES: IF UNIT IS PLACED LESS THAN 12 (304.8) FROM WALL SYSTEM, THEN SYSTEM PERFORMANCE MAY BE COMPROMISED. DIMENSIONS IN ( ) ARE IN MM

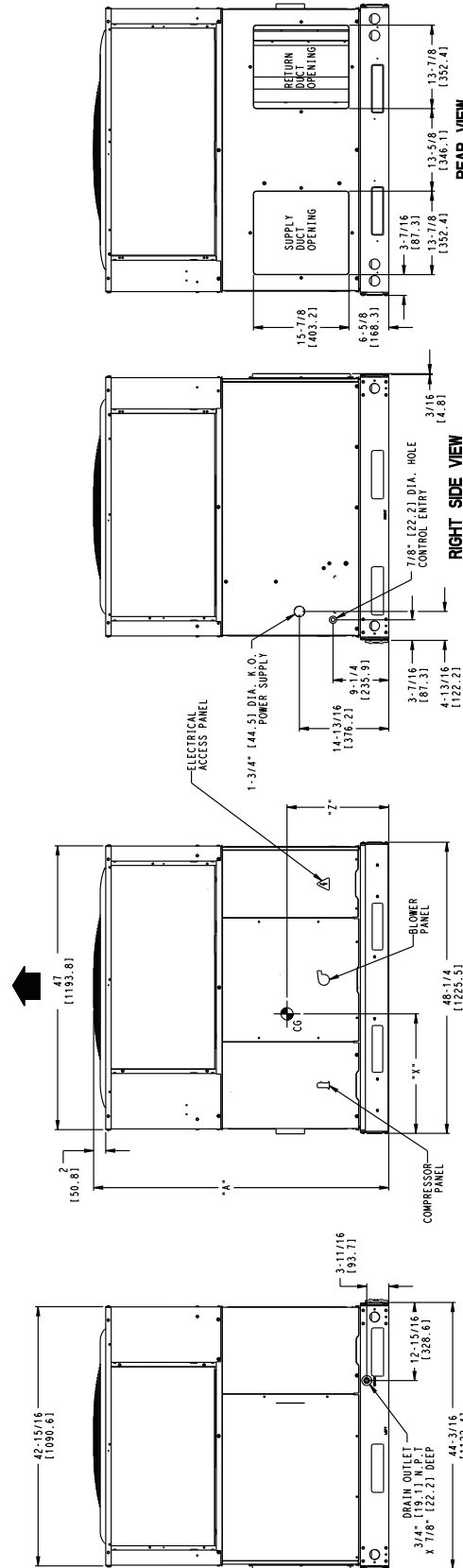
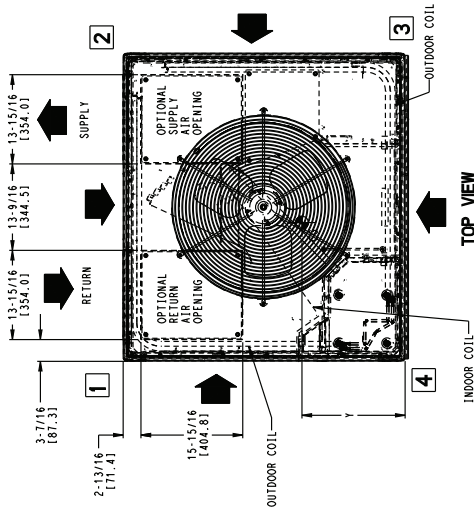

REV --  
50VL500496

PA4G

# ROOF CURB ACCESSORY - 24-60

PA4G

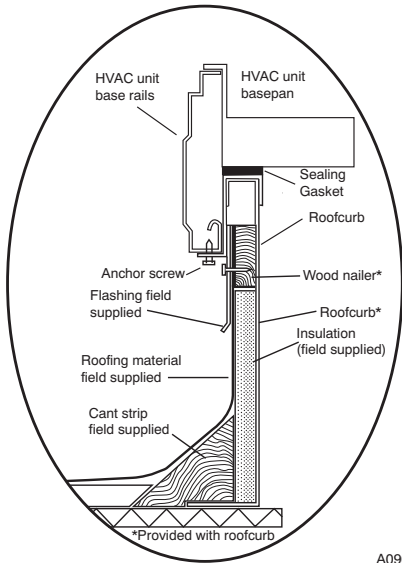

A09090

ROOF CURB DETAIL

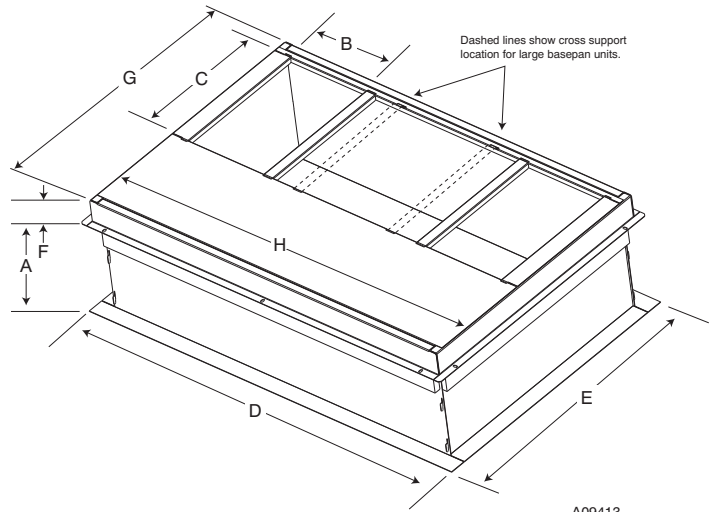

SMALL/COMMON CURB

A09413

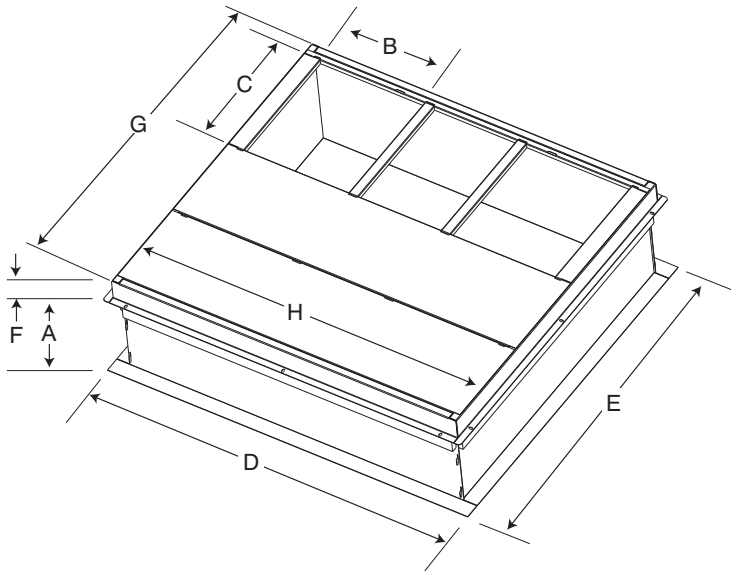

A09415

LARGE CURB

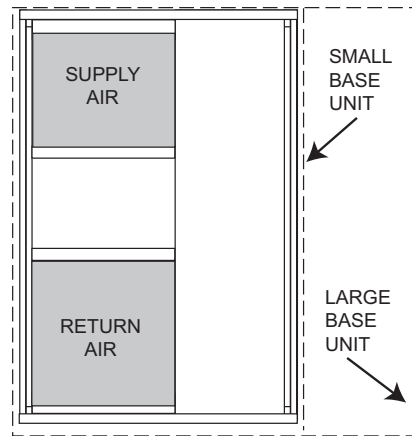

UNIT PLACEMENT ON COMMON CURB

A09094

SMALL OR LARGE BASE UNIT

A09414

UNIT SIZE	CATALOG NUMBER	A IN. (mm)	B (small/common base) IN. (mm)*	B (large base) IN. (mm)*	C IN. (mm)	D IN. (mm)	E IN. (mm)	F IN. (mm)	G IN. (mm)	H IN. (mm)
Small or Large	CPRFCURB010A00	11 (279)	10 (254)	14 (356)	16 (406)	47.8 (1214)	32.4 (822)	2.7 (69)	30.6 (778)	46.1 (1170)
	CPRFCURB011A00	14 (356)					43.9 (1116)			
Large	CPRFCURB012A00	11 (279)	14 (356)				43.9 (1116)		42.2 (1072)	
	CPRFCURB013A00	14 (356)								

\* Part Numbers CPRFCURB010A00 and CPRFCURB011A00 can be used on both small and large basepan units. The cross supports must be located based on whether the unit is a small basepan or a large basepan.

NOTES:

1. Roof curb must be set up for unit being installed.
2. Seal strip must be applied, as required, to unit being installed.
3. Roof curb is made of 16-gauge steel.
4. Attach ductwork to curb (flanges of duct rest on curb).
5. Insulated panels: 1-in. (25.4 mm) thick fiberglass 1 lb. density.

## SELECTION PROCEDURE (WITH EXAMPLE)

### 1. Determine cooling and heating requirements at design conditions:

Given:

Required Cooling Capacity (TC)	34,000 Btuh
Sensible Heat Capacity (SHC)	24,000 Btuh
Required Heating Capacity	12,500 Btuh
Condenser Entering Air Temperature	95°F(35°C)
Indoor-Air Temperature	80°F (26°C) edb 67°F (19°C) ewb
Evaporator Air Quantity	1200 CFM
External Static Pressure	0.20 IN. W.C.
Electrical Characteristics	230-1-60

### 2. Select unit based on required cooling capacity.

Enter Net Cooling Capacities table at condenser entering temperature of 95°F (35°C), indoor air entering at 1200 cfm and 67°F (19°C) ewb (entering wet bulb). The unit will provide a total capacity of 34,200 Btuh and a SHC of 24,500 Btuh.

### 3. Select electric heat.

The required heating capacity is 15,000 Btuh.

Determine additional electric heat capacity in kW.

$$\frac{15,000 \text{ Btuh}}{3,414 \text{ Btuh/kW}} = 4.4 \text{ kW of heat required}$$

Enter the electric Heater Packages table for 208/240, single-phase, 36 unit. The 5 kW heater at 240v most closely satisfies the heating required. To calculate kW at the 208v, multiply the heater kW by multiplication factor 0.75 found in the Wattage Multiplication Factors table.

$$5 \text{ kW} \times 0.75 = 3.75 \text{ kW}$$

$$3.75 \text{ kW} \times 3414 = 12802.50 \text{ Btuh}$$

### 4. Determine fan speed and power requirements at design conditions.

Before entering the air delivery tables, calculate the total static pressure required. From the given example, the Wet Coil Pressure Drop Table, and the Filter Pressure Drop Table:

External Static Pressure	0.200 IN. W.C.
Filter	0.000 IN. W.C.
Wet Coil Pressure Drop	<u>0.130 IN. W.C.</u>
Total Static Pressure	0.330 IN. W.C.

Enter the table for Wet Coil Air Delivery—horizontal discharge, 230. At 0.33 IN. W.C. ESP (external static pressure) and medium speed, the fan will deliver 1293 cfm. Adjusting for 208v, the motor delivers 114 cfm (deduct 10%).

### 5. Select unit that corresponds to power source available.

The Electrical Data Table shows that the unit is designed to operate at 208-1-60.

PERFORMANCE DATA

24 SIZE

EVAPORATOR AIR		CONDENSER ENTERING AIR TEMPERATURES ° F (° C)																															
		75 (23.9)			85 (29.4)			95 (35)			105 (40.6)			115 (46.1)			125 (51.7)																
		CFM/BF	EWB ° F (° C)	Capacity MBtuh	Total Sys KW	Capacity MBtuh	Total Sys KW	Capacity MBtuh	Total Sys KW	Capacity MBtuh	Total Sys KW	Capacity MBtuh	Total Sys KW	Capacity MBtuh	Total Sys KW	Capacity MBtuh	Total Sys KW																
		Total	Sens	Total	Sens	Total	Sens	Total	Sens	Total	Sens	Total	Sens	Total	Sens	Total	Sens																
		24 Outdoor Section With NONE Indoor Section																															
700/0.02	57 (13.8)	22.98	22.98	1.47	1.68	20.31	20.31	1.90	18.78	18.78	1.90	18.78	18.78	1.90	18.78	18.78	1.90	18.78	18.78	2.14	2.14	17.08	17.08	2.40	2.40	15.36	15.36	2.40	2.40	15.36	15.36	2.68	2.68
	62 (16.6)	23.82	21.37	1.48	1.68	20.58	19.70	1.91	18.81	18.81	1.91	18.81	18.81	1.91	18.81	18.81	1.91	18.81	18.81	2.14	2.14	17.11	17.11	2.40	2.40	15.39	15.39	2.40	2.40	15.39	15.39	2.68	2.68
	63* (17.2)	24.35	17.47	1.49	1.69	21.04	15.94	1.91	19.13	15.07	1.91	19.13	15.07	1.91	19.13	15.07	1.91	19.13	15.07	2.15	2.15	16.92	14.08	2.39	2.39	14.70	13.09	2.44	2.44	16.58	14.01	2.71	2.71
	67 (19.4)	26.42	18.21	1.49	1.71	23.03	16.75	1.95	21.14	15.93	1.95	21.14	15.93	1.95	21.14	15.93	1.95	21.14	15.93	2.20	2.20	18.89	14.98	2.42	2.42	16.58	14.01	2.42	2.42	16.58	14.01	2.71	2.71
	72 (22.2)	28.85	14.79	1.50	1.72	25.63	13.61	1.96	23.80	12.93	1.96	23.80	12.93	1.96	23.80	12.93	1.96	23.80	12.93	2.23	2.23	21.65	12.14	2.52	2.52	19.22	11.24	2.52	2.52	19.22	11.24	2.79	2.79
800/0.03	57 (13.8)	24.12	24.12	1.50	1.71	21.34	21.34	1.94	19.80	19.80	1.94	19.80	19.80	1.94	19.80	19.80	1.94	19.80	19.80	2.18	2.18	17.99	17.99	2.43	2.43	16.19	16.19	2.43	2.43	16.19	16.19	2.72	2.72
	62 (16.6)	24.50	23.07	1.50	1.71	21.38	21.38	1.94	19.84	19.84	1.94	19.84	19.84	1.94	19.84	19.84	1.94	19.84	19.84	2.18	2.18	18.02	18.02	2.44	2.44	16.22	16.22	2.44	2.44	16.22	16.22	2.72	2.72
	63* (17.2)	25.00	18.69	1.50	1.72	21.58	17.12	1.94	19.66	16.24	1.94	19.66	16.24	1.94	19.66	16.24	1.94	19.66	16.24	2.18	2.18	17.37	15.21	2.42	2.42	15.09	14.18	2.42	2.42	15.09	14.18	2.69	2.69
	67 (19.4)	27.05	19.46	1.51	1.72	23.60	18.00	1.97	21.66	17.17	1.97	21.66	17.17	1.97	21.66	17.17	1.97	21.66	17.17	2.23	2.23	19.36	16.20	2.47	2.47	17.00	15.20	2.47	2.47	17.00	15.20	2.74	2.74
	72 (22.2)	29.34	15.47	1.53	1.74	26.14	14.36	1.98	24.31	13.70	1.98	24.31	13.70	1.98	24.31	13.70	1.98	24.31	13.70	2.25	2.25	22.19	12.94	2.54	2.54	19.67	12.02	2.54	2.54	19.67	12.02	2.83	2.83
900/0.04	57 (13.8)	25.11	25.11	1.52	1.74	22.22	22.22	1.97	20.65	20.65	1.97	20.65	20.65	1.97	20.65	20.65	1.97	20.65	20.65	2.22	2.22	18.78	18.78	2.47	2.47	16.90	16.90	2.47	2.47	16.90	16.90	2.76	2.76
	62 (16.6)	25.16	25.16	1.52	1.74	22.26	22.26	1.97	20.68	20.68	1.97	20.68	20.68	1.97	20.68	20.68	1.97	20.68	20.68	2.22	2.22	18.81	18.81	2.47	2.47	16.93	16.93	2.47	2.47	16.93	16.93	2.76	2.76
	63* (17.2)	25.49	19.84	1.52	1.74	22.01	18.25	1.97	20.08	17.36	1.97	20.08	17.36	1.97	20.08	17.36	1.97	20.08	17.36	2.21	2.21	17.74	16.30	2.45	2.45	15.43	15.18	2.45	2.45	15.43	15.18	2.72	2.72
	67 (19.4)	27.52	20.63	1.53	1.74	24.04	19.20	1.98	22.07	18.37	1.98	22.07	18.37	1.98	22.07	18.37	1.98	22.07	18.37	2.25	2.25	19.75	17.37	2.50	2.50	17.35	16.33	2.50	2.50	17.35	16.33	2.77	2.77
	72 (22.2)	29.68	16.09	1.55	1.76	26.50	15.05	2.00	24.67	14.41	2.00	24.67	14.41	2.00	24.67	14.41	2.00	24.67	14.41	2.27	2.27	22.61	13.70	2.57	2.57	20.03	12.76	2.57	2.57	20.03	12.76	2.86	2.86

See Legend and Notes on Page 18.

# PERFORMANCE DATA (CONT)

## 30 SIZE

EVAPORATOR AIR		CONDENSER ENTERING AIR TEMPERATURES °F (°C)																	
		75 (23.9)			85 (29.4)			95 (35)			105 (40.6)			115 (46.1)			125 (51.7)		
		Capacity MBtuh	Total Sys KW	Total Capacity MBtuh	Total Sys KW	Total Capacity MBtuh	Total Sys KW	Total Capacity MBtuh	Total Sys KW	Total Capacity MBtuh	Total Sys KW	Total Capacity MBtuh	Total Sys KW	Total Capacity MBtuh	Total Sys KW	Total Capacity MBtuh	Total Sys KW		
<b>CFM/BF</b>	<b>EWB °F (°C)</b>	<b>30 Outdoor Section With NONE Indoor Section</b>																	
		57 (13.8)	26.99	1.86	26.03	2.08	24.84	2.31	23.28	2.55	21.63	2.82	20.84	2.82	19.83	2.82	19.83	3.11	
		62 (16.6)	27.80	1.87	26.54	2.08	25.04	2.31	23.33	2.55	21.67	2.82	20.84	2.82	19.87	2.82	19.87	3.11	
		63* (17.2)	28.37	1.87	27.09	2.09	25.54	2.32	23.41	2.55	21.13	2.81	20.84	2.81	18.66	2.81	18.66	3.08	
		67 (19.4)	30.73	1.86	29.48	2.10	27.98	2.35	25.91	2.59	18.78	2.85	21.10	2.85	17.72	2.85	17.72	3.13	
72 (22.2)	33.46	1.87	32.40	2.10	31.09	2.36	29.42	2.64	15.10	2.93	24.52	2.93	14.14	2.93	14.14	3.21			
<b>875/0.03</b>	57 (13.8)	28.26	1.89	27.27	2.12	26.09	2.36	24.45	2.59	22.72	2.87	20.84	2.87	20.84	2.87	20.84	3.16		
	62 (16.6)	28.57	1.89	27.32	2.13	26.13	2.36	24.49	2.60	22.76	2.87	20.87	2.87	20.87	2.87	20.87	3.16		
	63* (17.2)	29.05	1.89	27.73	2.13	26.16	2.36	23.97	2.59	21.65	2.85	19.13	2.85	17.84	2.85	17.84	3.12		
	67 (19.4)	31.37	1.89	30.12	2.12	28.60	2.38	26.53	2.63	24.15	2.89	21.60	2.89	19.20	2.89	19.20	3.18		
	72 (22.2)	33.95	1.90	32.92	2.14	31.61	2.39	30.05	2.68	27.65	2.98	25.04	2.98	25.04	2.98	25.04	3.26		
<b>1000/0.04</b>	57 (13.8)	29.32	1.92	28.31	2.15	27.10	2.41	25.45	2.64	23.65	2.91	21.70	2.91	21.70	2.91	21.70	3.21		
	62 (16.6)	29.36	1.92	28.35	2.15	27.14	2.41	25.49	2.64	23.68	2.92	21.73	2.92	21.73	2.92	21.73	3.21		
	63* (17.2)	29.55	1.92	28.22	2.15	26.63	2.40	24.43	2.62	22.07	2.88	19.66	2.88	19.66	2.88	19.66	3.17		
	67 (19.4)	31.84	1.92	30.59	2.15	29.08	2.41	27.00	2.68	24.60	2.93	22.02	2.93	22.02	2.93	22.02	3.22		
	72 (22.2)	34.29	1.94	33.28	2.17	31.97	2.43	30.44	2.71	28.11	3.01	25.43	3.01	25.43	3.01	25.43	3.31		

See Legend and Notes on Page 18.



PERFORMANCE DATA (CONT)

36 SIZE

EVAPORATOR AIR CFM/BF	EWB °F (°C)	CONDENSER ENTERING AIR TEMPERATURES °F (°C)																	
		75 (23.9)			85 (29.4)			95 (35)			105 (40.6)			115 (46.1)			125 (51.7)		
		Capacity MBtuh	Total Sys KW	Sens	Capacity MBtuh	Total Sys KW	Sens	Capacity MBtuh	Total Sys KW	Sens	Capacity MBtuh	Total Sys KW	Sens	Capacity MBtuh	Total Sys KW	Sens	Capacity MBtuh	Total Sys KW	Sens
<b>36 Outdoor Section With NONE Indoor Section</b>																			
<b>1050/0.04</b>	<sup>57</sup> (13.8)	32.04	2.19	31.05	2.46	29.67	2.74	27.89	3.04	25.97	3.38	23.86	3.76						
	<sup>62</sup> (16.6)	32.91	2.20	31.59	2.46	29.83	2.74	27.93	3.04	26.01	3.38	23.90	3.76						
	<sup>63*</sup> (17.2)	33.62	2.21	32.24	2.47	30.40	2.75	27.88	3.04	25.18	3.37	22.23	3.72						
	<sup>67</sup> (19.4)	36.45	2.21	35.13	2.49	33.48	2.80	30.96	3.09	28.22	3.42	25.24	3.78						
	<sup>72</sup> (22.2)	39.67	2.22	38.63	2.50	37.24	2.81	35.25	3.16	32.48	3.51	29.45	3.88						
<b>1200/0.05</b>	<sup>57</sup> (13.8)	33.50	2.25	32.48	2.53	31.16	2.81	29.25	3.11	27.24	3.46	25.04	3.83						
	<sup>62</sup> (16.6)	33.79	2.25	32.53	2.53	31.22	2.82	29.30	3.11	27.28	3.46	25.08	3.84						
	<sup>63*</sup> (17.2)	34.36	2.25	32.96	2.53	31.14	2.81	28.52	3.10	25.75	3.43	22.79	3.79						
	<sup>67</sup> (19.4)	37.19	2.25	35.85	2.54	34.20	2.85	31.64	3.16	28.84	3.49	25.80	3.85						
	<sup>72</sup> (22.2)	40.13	2.27	39.14	2.55	37.77	2.86	35.97	3.21	33.15	3.58	30.03	3.95						
<b>1350/0.06</b>	<sup>57</sup> (13.8)	34.72	2.30	33.67	2.58	32.38	2.89	30.42	3.18	28.32	3.53	26.03	3.91						
	<sup>62</sup> (16.6)	34.77	2.30	33.72	2.58	32.42	2.89	30.47	3.19	28.36	3.53	26.07	3.91						
	<sup>63*</sup> (17.2)	34.95	2.30	33.50	2.58	31.73	2.88	29.03	3.16	26.24	3.49	23.49	3.85						
	<sup>67</sup> (19.4)	37.71	2.30	36.39	2.58	34.73	2.90	32.19	3.22	29.33	3.55	26.31	3.92						
	<sup>72</sup> (22.2)	40.41	2.32	39.47	2.60	38.09	2.91	36.46	3.26	33.65	3.64	30.47	4.02						

See Legend and Notes on Page 18.

# PERFORMANCE DATA (CONT)

## 42 SIZE

EVAPORATOR AIR CFM/BF	EWB °F (°C)	CONDENSER ENTERING AIR TEMPERATURES °F (°C)																	
		75 (23.9)			85 (29.4)			95 (35)			105 (40.6)			115 (46.1)			125 (51.7)		
		Capacity MBtuh	Total Sens	Total Sys KW	Capacity MBtuh	Total Sens	Total Sys KW	Capacity MBtuh	Total Sens	Total Sys KW	Capacity MBtuh	Total Sens	Total Sys KW	Capacity MBtuh	Total Sens	Total Sys KW	Capacity MBtuh	Total Sens	Total Sys KW
		<b>42 Outdoor Section With NONE Indoor Section</b>																	
<b>1225/0.03</b>	57 (13.8)	39.61	39.61	2.72	37.75	37.75	3.11	35.18	35.18	3.47	32.60	32.60	3.87	29.87	29.87	4.29	27.01	27.01	4.72
	62 (16.6)	41.07	38.45	2.67	38.75	36.39	3.09	35.55	33.89	3.46	32.66	32.66	3.87	29.92	29.92	4.29	27.06	27.06	4.72
	63* (17.2)	41.95	31.44	2.64	39.60	29.62	3.07	36.33	27.46	3.45	32.90	25.32	3.87	29.27	23.19	4.30	25.42	21.06	4.73
	67 (19.4)	45.37	32.67	2.53	43.06	30.92	2.96	39.97	28.94	3.40	36.45	26.82	3.83	32.72	24.71	4.27	28.81	22.62	4.72
	72 (22.2)	49.27	26.39	2.42	46.93	24.87	2.85	44.47	23.37	3.31	41.33	21.77	3.74	37.56	19.92	4.23	33.52	18.06	4.71
<b>1400/0.04</b>	57 (13.8)	41.50	41.50	2.69	39.58	39.58	3.11	36.97	36.97	3.49	34.25	34.25	3.90	31.39	31.39	4.32	28.40	28.40	4.76
	62 (16.6)	42.21	41.36	2.67	39.89	39.13	3.10	37.03	37.03	3.49	34.31	34.31	3.89	31.45	31.45	4.32	28.45	28.45	4.76
	63* (17.2)	42.97	33.53	2.65	40.58	31.68	3.08	37.25	29.48	3.49	33.72	27.26	3.90	29.98	25.02	4.34	26.10	22.75	4.77
	67 (19.4)	46.35	34.80	2.54	43.98	33.00	2.97	41.00	31.10	3.42	37.31	28.90	3.87	33.50	26.70	4.31	29.50	24.50	4.76
	72 (22.2)	50.00	27.51	2.44	47.63	26.00	2.87	45.07	24.46	3.33	42.19	23.04	3.76	38.40	21.21	4.25	34.25	19.32	4.76
<b>1575/0.05</b>	57 (13.8)	43.07	43.07	2.68	41.12	41.12	3.10	38.51	38.51	3.52	35.67	35.67	3.92	32.70	32.70	4.36	29.59	29.59	4.80
	62 (16.6)	43.17	43.17	2.68	41.17	41.17	3.10	38.57	38.57	3.52	35.73	35.73	3.92	32.75	32.75	4.36	29.63	29.63	4.80
	63* (17.2)	43.75	35.51	2.67	41.32	33.62	3.10	37.99	31.40	3.52	34.37	29.08	3.94	30.58	26.74	4.37	26.77	26.77	4.81
	67 (19.4)	47.03	36.77	2.56	44.64	34.95	2.99	41.77	33.12	3.44	38.00	30.88	3.90	34.12	28.58	4.35	30.10	26.23	4.80
	72 (22.2)	50.51	28.53	2.47	48.10	27.01	2.90	45.48	25.44	3.37	42.80	24.21	3.79	39.02	22.42	4.27	34.83	20.52	4.79

See Legend and Notes on Page 18.

PERFORMANCE DATA (CONT)

48 SIZE

EVAPORATOR AIR CFM/BF	EWB °F (°C)	CONDENSER ENTERING AIR TEMPERATURES °F (°C)																		
		75 (23.9)			85 (29.4)			95 (35)			105 (40.6)			115 (46.1)			125 (51.7)			
		Capacity MBtuh	Total Sys KW	Sens	Capacity MBtuh	Total Sys KW	Sens	Capacity MBtuh	Total Sys KW	Sens	Capacity MBtuh	Total Sys KW	Sens	Capacity MBtuh	Total Sys KW	Sens	Capacity MBtuh	Total Sys KW	Sens	
<b>48 Outdoor Section With NONE Indoor Section</b>																				
<b>1400/0.04</b>	57 (13.8)	45.84	2.98	43.32	3.39	40.27	3.79	36.93	4.23	33.57	4.70	30.16	5.21							
	62 (16.6)	47.63	3.00	44.58	3.40	40.96	3.80	36.99	4.23	33.63	4.70	30.21	5.21							
	63* (17.2)	48.63	3.00	45.52	3.41	41.85	3.82	37.52	4.23	33.20	4.69	28.77	5.18							
	67 (19.4)	52.66	2.99	49.43	3.41	46.02	3.86	41.50	29.66	4.31	37.03	4.77	32.47	5.27						
	72 (22.2)	57.51	2.99	54.21	3.41	50.75	3.86	46.93	24.09	4.35	42.34	4.88	37.63	5.42						
	57 (13.8)	47.96	3.06	45.32	3.47	42.32	3.89	38.76	38.76	4.32	35.24	4.80	31.66	5.31						
<b>1600/0.05</b>	62 (16.6)	48.90	3.06	45.80	3.47	42.41	3.89	38.82	4.32	35.30	4.80	31.72	5.32							
	63* (17.2)	49.79	3.06	46.56	3.47	42.93	3.90	38.42	4.31	33.97	4.77	29.47	5.26							
	67 (19.4)	53.81	3.05	50.48	3.46	47.00	3.92	42.43	31.88	4.39	37.88	4.86	33.20	5.35						
	72 (22.2)	58.37	3.05	55.05	3.47	51.47	3.93	47.81	25.40	4.41	43.22	4.94	38.39	5.50						
	57 (13.8)	49.74	3.12	47.00	3.53	44.06	3.98	40.29	4.41	36.64	4.89	32.92	5.41							
	62 (16.6)	50.02	3.11	47.06	3.53	44.13	3.98	40.35	4.41	36.69	4.89	32.97	5.41							
<b>1800/0.06</b>	63* (17.2)	50.68	3.11	47.38	3.53	43.79	3.98	39.13	4.38	34.61	4.84	30.08	5.33							
	67 (19.4)	54.66	3.10	51.27	3.52	47.75	3.97	43.18	4.47	38.53	4.93	33.83	5.44							
	72 (22.2)	58.98	3.11	55.61	3.53	51.97	3.99	48.35	4.48	43.87	4.99	38.98	5.56							

See Legend and Notes on Page 18.



# PERFORMANCE DATA (CONT)

## 60 SIZE

EVAPORATOR AIR		CONDENSER ENTERING AIR TEMPERATURES °F (°C)																	
		75 (23.9)			85 (29.4)			95 (35)			105 (40.6)			115 (46.1)			125 (51.7)		
		Capacity MBtuh	Total Sys KW	Sens	Capacity MBtuh	Total Sys KW	Sens	Capacity MBtuh	Total Sys KW	Sens	Capacity MBtuh	Total Sys KW	Sens	Capacity MBtuh	Total Sys KW	Sens	Capacity MBtuh	Total Sys KW	Sens
<b>1750/0.19</b>	57 (13.8)	57.97	3.80	55.02	4.21	51.93	4.68	48.68	5.21	45.23	5.81	41.56	6.49						
	62 (16.6)	59.45	3.82	55.93	4.22	49.43	4.68	48.74	5.21	45.29	5.81	41.61	6.49						
	63* (17.2)	60.48	3.83	56.84	4.23	39.89	4.69	49.17	5.21	45.08	5.80	40.81	6.47						
	67 (19.4)	65.05	3.88	61.08	4.29	41.50	4.75	52.75	5.27	48.31	5.86	43.70	6.52						
	72 (22.2)	71.36	3.97	66.97	4.38	33.17	4.83	57.72	5.35	52.82	5.94	47.74	6.59						
	57 (13.8)	60.36	3.91	57.19	4.32	53.88	4.79	50.41	5.31	46.72	5.91	42.83	6.59						
	62 (16.6)	60.82	3.91	57.29	4.32	53.96	4.79	50.47	5.32	46.78	5.92	42.88	6.59						
<b>2000/0.23</b>	63* (17.2)	61.65	3.92	57.84	4.33	53.93	4.78	49.88	5.30	45.65	5.89	41.27	6.56						
	67 (19.4)	66.24	3.98	62.11	4.39	44.46	4.85	53.47	5.36	48.88	6.03	44.14	6.61						
	72 (22.2)	72.62	4.06	68.04	4.47	63.32	4.93	58.45	5.45	53.38	6.03	48.15	6.68						
	57 (13.8)	62.35	4.01	58.99	4.43	55.49	4.89	51.82	5.42	47.93	6.02	43.84	6.69						
	62 (16.6)	62.44	4.01	59.07	4.43	55.56	4.89	51.88	5.42	47.99	6.02	43.88	6.69						
	63* (17.2)	62.51	4.01	58.59	4.42	54.57	4.87	50.40	5.39	46.08	5.98	41.62	6.65						
	67 (19.4)	67.13	4.07	62.86	4.48	58.50	4.94	53.98	5.46	49.29	6.04	44.47	6.70						
72 (22.2)	73.55	4.16	68.82	4.57	63.97	5.02	58.95	5.54	53.76	6.12	48.40	6.77							

## PERFORMANCE DATA (CONT)

\* At 75°F (24°C) entering dry bulb – Tennessee Valley Authority (TVA) rating conditions; all others at 80°F (27°C) dry bulb.

### LEGEND

BF—Bypass Factor  
 edb—Entering Dry—Bulb  
 Ewb—Entering Wet—Bulb  
 kW—Total Unit Power Input  
 SHC—Sensible Heat Capacity (1000 Btuh)  
 TC—Total Capacity (1000 Btuh) (net)  
 rh—Relative Humidity

### COOLING NOTES:

1. Ratings are net; they account for the effects of the evaporator—fan motor power and heat.
2. Direct interpolation is permissible. Do not extrapolate.
3. The following formulas may be used:

$$t_{ldb} = t_{edb} - \frac{\text{Sensible capacity (Btuh)}}{1.10 \times \text{cfm}}$$

$$t_{lwb} = \text{Wet-bulb temperature corresponding to enthalpy air leaving evaporator coil } (h_{lwb}) \quad h_{lwb} = h_{ewb} - \frac{\text{total capacity (Btuh)}}{4.5 \times \text{cfm}}$$

Where:  $h_{ewb}$  = Enthalpy of air entering evaporator coil

4. The SHC is based on 805 F (26.6°C) edb temperature of air entering evaporator coil. Below 80°F (26.6°C) edb, subtract (corr factor x cfm) from SHC. Above 80°F (26.6°C) edb, add (corr factor x cfm) to SHC.

Correction Factor =  $1.10 \times (1 + BF) \times (edb - 80)$ .

5. Integrated capacity is maximum (instantaneous) capacity less the effect of frost on the outdoor coil and the heat required to defrost it.

# PERFORMANCE DATA (CONT)

## Multiplication Factors

HEATER KW RATING		VOLTAGE DISTRIBUTION V/3/60				MULTIPLICATION FACTOR			
240		200	0.89						
		208	0.75						
		230	0.92						
		240	1.00						

## Dry Coil Air Delivery\* - Horizontal Discharge - Unit 24-60

UNIT SIZE	MOTOR SPEED	WIRE COLOR	EXTERNAL STATIC PRESSURE (IN. W.C.)																	
			0.1	0.2	0.3	0.4	0.5	0.6	0.7	0.8	0.9									
24	Low	Blue	CFM	754	650	538	429	---	---	---	---	---	---	---	---	---	---	---	---	---
	Med-Low	Pink	CFM	851	777	675	591	475	---	---	---	---	---	---	---	---	---	---	---	---
	Medium <sup>1</sup>	Red	CFM	941	851	774	684	576	479	---	---	---	---	---	---	---	---	---	---	---
	Med-High	Orange	CFM	1009	917	840	759	667	577	479	---	---	---	---	---	---	---	---	---	---
	High	Black	CFM	1241	1167	1111	1036	969	881	818	731	640	---	---	---	---	---	---	---	---
	Low	Blue	CFM	741	638	547	415	---	---	---	---	---	---	---	---	---	---	---	---	---
	Med-Low	Pink	CFM	973	887	823	733	665	538	451	---	---	---	---	---	---	---	---	---	---
	Medium	Red	CFM	1088	1023	954	881	800	723	658	563	461	---	---	---	---	---	---	---	---
	Med-High <sup>1</sup>	Orange	CFM	1140	1064	996	915	840	758	687	564	480	---	---	---	---	---	---	---	---
	High	Black	CFM	1202	1140	1082	1015	961	881	810	732	631	---	---	---	---	---	---	---	---
30	Low	Blue	CFM	1234	1168	1093	1021	961	894	825	759	687	---	---	---	---	---	---	---	---
	Med-Low	Pink	CFM	1290	1223	1154	1090	1027	977	894	828	762	---	---	---	---	---	---	---	---
	Medium <sup>1</sup>	Red	CFM	1354	1290	1226	1158	1102	1046	981	918	843	---	---	---	---	---	---	---	---
	Med-High	Orange	CFM	1606	1546	1489	1430	1371	1316	1258	1208	1140	---	---	---	---	---	---	---	---
	High	Black	CFM	1630	1580	1517	1463	1407	1339	1277	1210	1131	---	---	---	---	---	---	---	---
	Low	Blue	CFM	1295	1234	1182	1126	1075	1016	955	898	857	---	---	---	---	---	---	---	---
	Med-Low	Pink	CFM	1345	1282	1235	1194	1140	1095	1027	974	921	---	---	---	---	---	---	---	---
	Medium	Red	CFM	1505	1452	1413	1358	1323	1282	1234	1169	1130	---	---	---	---	---	---	---	---
	Med-High <sup>1</sup>	Orange	CFM	1545	1492	1449	1411	1362	1313	1278	1231	1188	---	---	---	---	---	---	---	---
	High	Black	CFM	1705	1643	1607	1568	1518	1483	1448	1404	1360	---	---	---	---	---	---	---	---
42	Low	Blue	CFM	1402	1351	1311	1263	1224	1172	1136	1080	1041	---	---	---	---	---	---	---	---
	Med-Low	Pink	CFM	1457	1404	1367	1318	1284	1233	1197	1144	1104	---	---	---	---	---	---	---	---
	Medium <sup>1</sup>	Red	CFM	1736	1695	1642	1601	1553	1512	1465	1427	1381	---	---	---	---	---	---	---	---
	Med-High	Orange	CFM	2149	2111	2062	2026	1980	1945	1905	1864	1793	---	---	---	---	---	---	---	---
	High	Black	CFM	2344	2306	2259	2203	2141	2070	1991	1902	1803	---	---	---	---	---	---	---	---
	Med-Low	Pink	CFM	1678	1635	1602	1558	1513	1474	1438	1404	1349	---	---	---	---	---	---	---	---
	Medium <sup>1</sup>	Red	CFM	1962	1915	1880	1843	1794	1753	1711	1675	1628	---	---	---	---	---	---	---	---
	Med-High	Orange	CFM	2131	2088	2065	2013	1982	1941	1888	1860	1785	---	---	---	---	---	---	---	---
	High	Black	CFM	2461	2409	2339	2286	2192	2140	2062	1968	1874	---	---	---	---	---	---	---	---

\* Air delivery values are without air filter and are for dry coil (See Wet Coil Pressure Drop table).

<sup>1</sup> Factory-shipped cooling speed

Note: Duct field-supplied air filter pressure drop and wet coil pressure drop to obtain external static pressure available for ducting.

Shaded areas indicate speed/static combinations that are not permitted for dehumidification speed.

Note: Duct 10% for 208 volt operation.



**Dry Coil Air Delivery - Downflow Discharge**

UNIT SIZE	MOTOR SPEED	WIRE COLOR		EXTERNAL STATIC PRESSURE (IN. W.C.)															
				0.10	0.20	0.30	0.40	0.50	0.60	0.70	0.80	0.90	1.0						
24	Low	Blue	CFM	809	664	554	447	--	--	--	--	--	--	--	--	--	--	--	
			WATTS	85	82	87	95	--	--	--	--	--	--	--	--	--	--	--	--
	MedLow	Pink	BHP	0.09	0.09	0.09	0.10	--	--	--	--	--	--	--	--	--	--	--	
			CFM	875	787	693	612	498	392	--	--	--	--	--	--	--	--	--	--
				WATTS	101	111	115	125	131	142	--	--	--	--	--	--	--	--	--
				BHP	0.11	0.12	0.12	0.13	0.14	0.15	--	--	--	--	--	--	--	--	--
				CFM	939	860	748	663	591	472	399	--	--	--	--	--	--	--	--
				WATTS	119	124	134	138	147	155	164	--	--	--	--	--	--	--	--
				BHP	0.13	0.13	0.14	0.15	0.16	0.17	0.18	--	--	--	--	--	--	--	--
				1026	1026	949	873	786	694	604	516	--	--	--	--	--	--	--	--
				146	146	151	161	167	177	183	195	--	--	--	--	--	--	--	--
				BHP	0.16	0.16	0.17	0.18	0.19	0.20	0.21	--	--	--	--	--	--	--	--
			1264	1264	1202	1134	1070	1002	931	870	806	699	610	--	--	--	--	--	
			250	250	261	274	279	290	296	308	319	328	332	--	--	--	--	--	
			BHP	0.27	0.28	0.29	0.30	0.31	0.32	0.33	0.34	0.35	0.36	--	--	--	--	--	
			CFM	756	669	548	457	--	--	--	--	--	--	--	--	--	--	--	--
			WATTS	84	90	96	106	--	--	--	--	--	--	--	--	--	--	--	
			BHP	0.09	0.10	0.10	0.11	--	--	--	--	--	--	--	--	--	--	--	--
30	Low	Blue	CFM	1002	928	842	733	660	560	450	--	--	--	--	--	--	--	--	
			WATTS	144	155	161	173	185	192	203	--	--	--	--	--	--	--	--	--
	MedLow	Pink	BHP	0.15	0.17	0.17	0.19	0.20	0.21	0.22	--	--	--	--	--	--	--	--	
			CFM	1110	1025	967	879	814	706	611	509	--	--	--	--	--	--	--	--
				WATTS	188	195	205	211	223	236	243	255	--	--	--	--	--	--	--
				BHP	0.20	0.21	0.22	0.23	0.24	0.25	0.26	0.27	--	--	--	--	--	--	--
				CFM	1160	1091	1004	945	866	804	699	615	496	--	--	--	--	--	--
				WATTS	213	225	232	243	249	261	273	285	291	--	--	--	--	--	--
				BHP	0.23	0.24	0.25	0.26	0.27	0.28	0.29	0.31	0.31	--	--	--	--	--	--
				CFM	1240	1173	1110	1031	966	902	821	726	626	--	--	--	--	--	--
				WATTS	254	266	274	284	295	302	315	327	331	--	--	--	--	--	--
				BHP	0.27	0.29	0.29	0.30	0.32	0.32	0.34	0.35	0.35	--	--	--	--	--	--

**Dry Coil Air Delivery - Downflow Discharge**

UNIT SIZE	MOTOR SPEED	WIRE COLOR	EXTERNAL STATIC PRESSURE (IN. W.C.)									
			0.10	0.20	0.30	0.40	0.50	0.60	0.70	0.80	0.90	1.0
36	Low	CFM	1277	1215	1147	1094	1045	992	932	874	826	757
		WATTS	285	289	299	305	314	319	328	335	347	352
		BHP	0.31	0.31	0.32	0.33	0.34	0.34	0.35	0.36	0.37	0.38
	MedLow	CFM	1312	1260	1203	1153	1095	1050	995	943	889	829
		WATTS	314	324	329	340	344	355	361	372	382	387
		BHP	0.34	0.35	0.35	0.36	0.37	0.38	0.39	0.40	0.41	0.42
	Medium <sup>1</sup>	CFM	1381	1326	1269	1212	1161	1121	1070	1019	974	912
		WATTS	358	365	375	383	391	395	406	418	424	434
		BHP	0.38	0.39	0.40	0.41	0.42	0.42	0.44	0.45	0.45	0.47
	MedHigh	CFM	1631	1579	1525	1477	1423	1372	1336	1284	1233	1166
		WATTS	567	576	581	592	598	609	617	619	613	598
		BHP	0.61	0.62	0.62	0.63	0.64	0.65	0.66	0.66	0.66	0.64
High	CFM	1681	1633	1575	1526	1478	1415	1366	1312	1249	1159	
	WATTS	618	626	636	644	652	653	649	642	627	602	
	BHP	0.66	0.67	0.68	0.69	0.70	0.70	0.70	0.69	0.67	0.65	
42	Low	CFM	1365	1324	1284	1233	1181	1127	1084	1039	984	939
		WATTS	177	189	201	210	222	236	248	261	269	281
		BHP	0.19	0.20	0.22	0.23	0.24	0.25	0.27	0.28	0.29	0.30
	MedLow	CFM	1425	1384	1339	1301	1254	1199	1151	1104	1065	1015
		WATTS	197	210	223	235	248	257	271	284	296	305
		BHP	0.21	0.23	0.24	0.25	0.27	0.28	0.29	0.30	0.32	0.33
	Medium	CFM	1582	1549	1509	1469	1433	1392	1346	1300	1249	1213
		WATTS	267	280	294	308	322	336	344	359	374	387
		BHP	0.29	0.30	0.32	0.33	0.35	0.36	0.37	0.38	0.40	0.42
	MedHigh <sup>1</sup>	CFM	1623	1586	1553	1511	1470	1433	1393	1350	1309	1261
		WATTS	285	299	312	324	335	349	363	378	393	407
		BHP	0.31	0.32	0.33	0.35	0.36	0.37	0.39	0.41	0.42	0.44
High	CFM	1775	1736	1696	1660	1622	1588	1557	1516	1472	1426	
	WATTS	371	386	401	410	424	439	453	468	483	497	
	BHP	0.40	0.41	0.43	0.44	0.45	0.47	0.49	0.50	0.52	0.53	

**PA4G**

**Dry Coil Air Delivery - Downflow Discharge**

UNIT SIZE	MOTOR SPEED	WIRE COLOR	CFM	EXTERNAL STATIC PRESSURE (IN. W.C.)									
				0.10	0.20	0.30	0.40	0.50	0.60	0.70	0.80	0.90	1.0
48	Low	Blue	CFM	1503	1457	1423	1374	1330	1287	1241	1199	1153	1111
			WATTS	225	233	246	254	269	282	292	307	314	329
			BHP	0.24	0.25	0.26	0.27	0.29	0.30	0.31	0.33	0.34	0.35
	MedLow	Pink	CFM	1556	1508	1461	1432	1388	1346	1302	1256	1221	1188
			WATTS	244	261	268	281	290	305	319	330	345	353
			BHP	0.26	0.28	0.29	0.30	0.31	0.33	0.34	0.35	0.37	0.38
	Medium <sup>1</sup>	Red	CFM	1861	1822	1786	1758	1716	1688	1660	1619	1583	1559
			WATTS	400	417	426	441	452	467	482	492	507	519
			BHP	0.43	0.45	0.46	0.47	0.48	0.50	0.52	0.53	0.54	0.56
	MedHigh	Orange	CFM	2319	2291	2255	2230	2193	2166	2118	2057	1992	1887
			WATTS	758	769	787	799	808	823	822	805	780	737
			BHP	0.81	0.82	0.84	0.86	0.87	0.88	0.88	0.86	0.84	0.79
High	Black	CFM	2532	2487	2444	2391	2330	2259	2179	2111	2033	1949	
		WATTS	1014	1022	1015	994	965	935	898	858	823	786	
		BHP	1.09	1.10	1.09	1.07	1.03	1.00	0.96	0.92	0.88	0.84	
Low	Blue	CFM	1479	1436	1387	1346	1298	1253	1206	1160	1114	1061	
		WATTS	224	239	247	262	270	284	300	307	319	330	
		BHP	0.24	0.26	0.26	0.28	0.29	0.30	0.32	0.33	0.34	0.35	
MedLow	Pink	CFM	1841	1796	1761	1724	1690	1651	1616	1578	1527	1478	
		WATTS	425	434	453	460	476	485	501	508	525	542	
		BHP	0.46	0.47	0.49	0.49	0.51	0.52	0.54	0.54	0.56	0.58	
Medium <sup>1</sup>	Red	CFM	1944	1913	1872	1838	1801	1771	1731	1698	1655	1613	
		WATTS	486	501	511	529	537	554	565	578	595	603	
		BHP	0.52	0.54	0.55	0.57	0.58	0.59	0.61	0.62	0.64	0.65	
MedHigh	Orange	CFM	2178	2148	2105	2073	2036	2002	1967	1919	1845	1751	
		WATTS	674	691	703	717	733	743	758	754	734	701	
		BHP	0.72	0.74	0.75	0.77	0.79	0.80	0.81	0.81	0.79	0.75	
High	Black	CFM	2480	2432	2375	2322	2236	2161	2085	2006	1917	1808	
		WATTS	1029	1012	995	975	941	908	869	836	796	751	
		BHP	1.10	1.09	1.07	1.05	1.01	0.97	0.93	0.90	0.85	0.81	

\*Air delivery values are without air filter and are for dry coil (See Wet Coil Pressure Drop table).

<sup>1</sup> Factory-shipped cooling speed.

**NOTE:** Duct field-supplied air filter pressure drop and wet coil pressure drop to obtain external static pressure available for ducting. Shaded areas indicate speed/static combinations that are not permitted.

**PERFORMANCE DATA (CONT)**

**Wet Coil Pressure Drop (IN. W.C.)**

UNIT SIZE	STANDARD CFM (SCFM)																
	600	700	800	900	1000	1100	1200	1300	1400	1500	1600	1700	1800	1900	2000	2100	2200
24	0.03	0.04	0.04	0.05	0.06												
30				0.05	0.06	0.07	0.08	0.11									
36				0.06	0.06	0.09	0.10	0.11	0.14								
42					0.05	0.05	0.06	0.07	0.08	0.08	0.09	0.09	0.11				
48							0.04	0.06	0.09	0.10	0.10	0.11	0.12	0.13	0.14		
60								0.06	0.09	0.10	0.07	0.01	0.08	0.09	0.10	0.12	0.13

**Economizer with 1-in. Filter Pressure Drop (IN. W.C.)**

FILTER SIZE IN. (MM)	COOLING TONS	STANDARD CFM (SCFM)																
		600	700	800	900	1000	1100	1200	1300	1400	1500	1600	1700	1800	1900	2000	2100	2200
600-1400CFM 12x20x1+12x20x1 (305x508x25+305x508x25)	2.0,	-	-	-	0.09	0.14	0.16	0.18	0.25	0.28	0.3	-	-	-	-	-	-	-
	2.5,																	
	3.0																	
1200-1800 CFM 16x24x1+14x24x1 (406x610x25+356x610x25)	3.5,	-	-	-	-	-	-	-	0.10	0.11	0.12	0.13	0.14	0.16	-	-	-	-
	4.0																	
1500-2200 CFM 16x24x1+18x24x1 (406x610x25+457x610x25)	5.0	-	-	-	-	-	-	-	-	-	-	0.15	0.17	0.18	0.20	0.21	0.22	0.23

**Horizontal and Downflow Filter Pressure Drop Table (IN. W.C.)**

FILTER SIZE IN. (MM)	COOLING TONS	STANDARD CFM (SCFM)																
		600	700	800	900	1000	1100	1200	1300	1400	1500	1600	1700	1800	1900	2000	2100	2200
600-1400CFM 12x20x1+12x20x1 (305x508x25+305x508x25)	2.0,	0.03	0.05	0.06	0.08	0.10	0.10	0.11	0.13	0.14	0.16	-	-	-	-	-	-	-
	2.5,																	
	3.0																	
1200-1800 CFM 16x24x1+14x24x1 (406x610x25+356x610x25)	3.5,	-	-	-	-	-	-	-	0.07	0.08	0.09	0.09	0.10	0.11	0.12	-	-	-
	4.0																	
1500-2200 CFM 16x24x1+18x24x1 (406x610x25+457x610x25)	5.0	-	-	-	-	-	-	-	-	-	-	0.04	0.06	0.08	0.10	0.11	0.13	0.15

**Electric Heat Pressure Drop Tables (IN. W.C.)  
Small Cabinet: 24-36**

STATIC	STANDARD CFM (SCFM)															
	500	600	700	800	900	1000	1100	1200	1300	1400	1500	1600				
5 kW	0.00	0.00	0.00	0.00	0.00	0.00	0.00	0.00	0.02	0.02	0.04	0.04	0.06	0.06	0.07	0.07
10 kW	0.00	0.00	0.00	0.00	0.00	0.02	0.04	0.06	0.06	0.07	0.09	0.10	0.10	0.10	0.11	0.11
15 kW	0.00	0.00	0.00	0.02	0.04	0.06	0.08	0.10	0.12	0.12	0.14	0.14	0.16	0.16	0.18	0.18
20 kW	0.00	0.00	0.02	0.04	0.06	0.08	0.09	0.11	0.13	0.15	0.17	0.17	0.19	0.19	0.21	0.21

**Large Cabinet: 42-60**

STATIC	STANDARD CFM (SCFM)															
	1100	1200	1300	1400	1500	1600	1700	1800	1900	2000	2100	2200	2300	2400	2500	
5 kW	0.00	0.00	0.00	0.01	0.02	0.03	0.04	0.05	0.06	0.07	0.08	0.09	0.10	0.11	0.12	
10 kW	0.00	0.00	0.01	0.02	0.03	0.04	0.05	0.06	0.07	0.08	0.09	0.10	0.11	0.12	0.13	
15 kW	0.00	0.02	0.03	0.04	0.05	0.06	0.07	0.08	0.09	0.10	0.11	0.12	0.13	0.14	0.15	
20 kW	0.02	0.03	0.04	0.05	0.06	0.07	0.08	0.09	0.10	0.11	0.12	0.13	0.14	0.15	0.16	



# TYPICAL PIPING AND WIRING

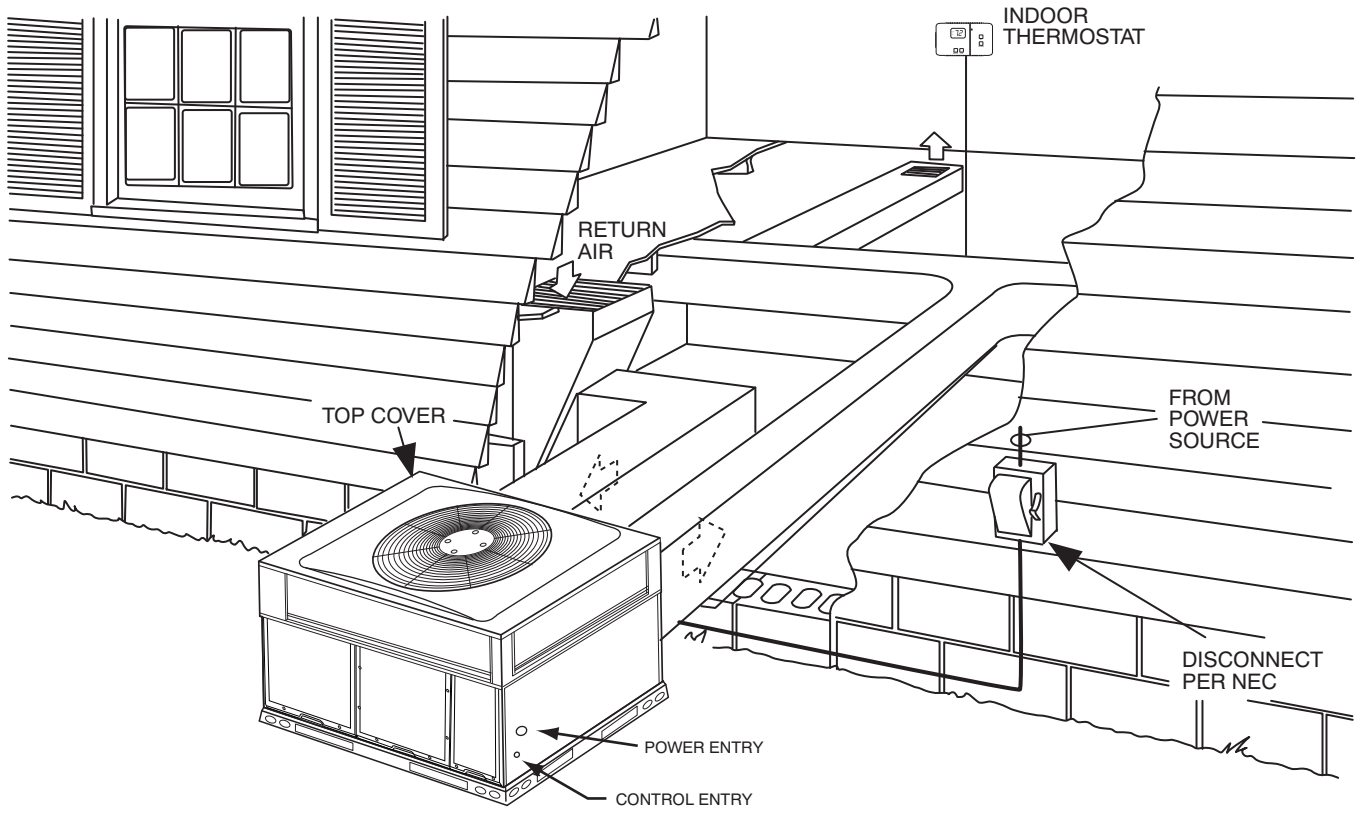

PA4G

A09423

## APPLICATION DATA

**Condensate trap** — A 2-in. (50.8 mm) condensate trap must be field supplied.

**Ductwork** — Secure downflow discharge ductwork to roof curb. For horizontal discharge applications, attach ductwork to unit with flanges.

**To convert a unit to downflow discharge** — Units are equipped with factory-installed inserts in the downflow openings. Removal of the inserts is similar to removing an electrical knock-out.

**Maximum cooling airflow** — To minimize the possibility of condensate blow-off from the evaporator, airflow through the units should not exceed 450 cfm per ton.

**Minimum cooling airflow** — Minimum cooling airflow is 350 cfm per ton.

**Minimum ambient cooling operation temperature** — All standard units have a minimum ambient operating temperature of 40°F (4°C). With accessory low ambient temperature kit, units can operate at temperatures down to 0°F (-17°C).

# ELECTRICAL DATA

NOMINAL SIZE	V-Ph-Hz	VOLTAGE RANGE		COMPRESSOR		OFM	IFM	ELECTRIC HEAT		POWER SUPPLY	
		MIN	MAX	RLA	LRA	FLA	FLA	NOMINAL KW	FLA	MCA	MOCP
24	208/230-1-60	197	253	13.5	58.3	0.7	4.1	-/-	-/-	21.7	30
								3.8/5	18.1/20.8	27.8/31.1	30/35
								5.4/7.2	25.9/30	37.5/42.6	40/45
								7.5/10	36.1/41.7	50.3/57.3	60/60
30	208/230-1-60	197	253	12.8	64	0.7	4.1	-/-	-/-	20.8	30
								3.8/5	18.1/20.8	27.8/31.1	30/35
								5.4/7.2	25.9/30	37.5/42.6	40/45
								7.5/10	36.1/41.7	50.3/57.3	60/60
	208/230-3-60	197	253	8.3	77	0.7	4.1	-/-	-/-	15.2	20
								3.8/5	10.4/12	18.1/20.1	20/25
								7.5/10	20.8/24.1	31.1/35.3	35/40
								11.3/15	31.2/36.1	44.1/50.3	45/60
36	208/230-1-60	197	253	14.1	77	1.2	6.0	-/-	-/-	24.8	35
								3.8/5	18.1/20.8	30.1/33.5	35/35
								5.4/7.2	25.9/30	39.9/45	40/45
								7.5/10	36.1/41.7	52.6/59.6	60/60
	208/230-3-60	197	253	9	77	1.2	6.0	-/-	-/-	18.5	25
								3.8/5	10.4/12	20.5/22.5	25/25
								7.5/10	20.8/24.1	33.5/37.6	35/40
								11.3/15	31.2/36.1	46.5/52.6	50/60
	460-3-60	414	506	5.6	38	0.5	3.0	-/-	-/-	10.5	15
								3.8/5	6	11.3/11.3	15
								7.5/10	12	18.8/18.8	20
								11.3/15	18	26.3/26.3	30
42	208/230-1-60	197	253	17.9	112	1.2	6.0	-/-	-/-	29.6	40
								3.8/5	18.1/20.8	30.1/33.5	40/40
								5.4/7.2	25.9/30	39.9/45	40/45
								7.5/10	36.1/41.7	52.6/59.6	60/60
	208/230-3-60	197	253	13.5	112	1.2	6.0	-/-	-/-	24.1	35
								3.8/5	10.4/12	24.1/24.1	35/35
								7.5/10	20.8/24.1	33.5/37.6	35/40
								11.3/15	31.2/36.1	46.5/52.6	50/60
	460-3-60	414	506	6	44	0.5	3.0	-/-	-/-	11.0	15
								3.8/5	6	11.3/11.3	15
								7.5/10	12	18.8/18.8	20
								11.3/15	18	26.3/26.3	30
48	208/230-1-60	197	253	21.8	117	1.2	7.6	-/-	-/-	36.1	50
								3.8/5	18.1/20.8	36.1/36.1	50/50
								5.4/7.2	25.9/30	41.9/47	50/50
								7.5/10	36.1/41.7	54.6/61.6	60/70
	208/230-3-60	197	253	13.7	117	1.2	7.6	-/-	-/-	25.9	35
								3.8/5	10.4/12	25.9/25.9	35/35
								7.5/10	20.8/24.1	35.5/39.6	40/40
								11.3/15	31.2/36.1	48.5/54.6	50/60
	460-3-60	414	506	6.2	41	0.5	3.8	-/-	-/-	12.1	15
								3.8/5	6	12.3/12.3	15
								7.5/10	12	19.8/19.8	20
								11.3/15	18	27.3/27.3	30
60	208/230-1-60	197	253	26.4	134	1.2	7.6	-/-	-/-	41.8	60
								3.8/5	18.1/20.8	41.8/41.8	60/60
								5.4/7.2	25.9/30	41.9/47	60/60
								7.5/10	36.1/41.7	54.6/61.6	60/70
	208/230-3-60	197	253	16	134	1.2	7.6	-/-	-/-	28.8	40
								3.8/5	10.4/12	28.8/28.8	40/40
								7.5/10	20.8/24.1	35.5/39.6	40/40
								11.3/15	31.2/36.1	48.5/54.6	50/60

PA4G

## ELECTRICAL DATA (CONT)

UNIT	V-Ph-Hz	VOLTAGE RANGE		COMPRESSOR		OFM	IFM	ELECTRIC HEAT		POWER SUPPLY	
		MIN	MAX	RLA	LRA	FLA	FLA	NOMINAL kW	FLA	MCA	MOCP
60	460-3-60	414	506	7.8	52	0.5	3.8	-/-	-/-	14.1	20
								3.8/5	6	14.1/14.1	20
								7.5/10	12	19.8/19.8	20
								11.3/15	18	27.3/27.3	30
								15/20	24.1	34.9/34.9	35

### LEGEND

FLA - Full Load Amps  
 IDM - Inducer Motor  
 IFM - Indoor Fan Motor  
 LRA - Locked Rotor Amps  
 MCA - Minimum Circuit Amps  
 MOCP - Maximum Over Current Protection  
 OFM - Outdoor Fan Motor  
 RLA - Rated Load Amps

### NOTES:

- In compliance with NEC (National Electrical Code) requirements for multimotor and combination load equipment (refer to NEC Articles 430 and 440), the overcurrent protective device for the unit shall be Power Supply fuse or circuit breaker.
- Minimum wire size is based on 60 C copper wire. If other than 60 C wire is used, or if length exceeds wire length in table, determine size from NEC.
- Unbalanced 3-Phase Supply Voltage  
*Never operate a motor where a phase imbalance in supply voltage is greater than 2%.* Use the following formula to determine the percentage of voltage imbalance

% Voltage imbalance

$$= 100 \times \frac{\text{max voltage deviation from average voltage}}{\text{average voltage}}$$

EXAMPLE: Supply voltage is 230-3-60.

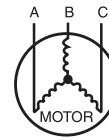

AB = 228 v  
 BC = 231 v  
 AC = 227 v

$$\begin{aligned}
 \text{Average Voltage} &= \frac{228 + 231 + 227}{3} \\
 &= \frac{686}{3} \\
 &= 229
 \end{aligned}$$

Determine maximum deviation from average voltage.

(AB) 229 - 228 = 1 v  
 (BC) 231 - 229 = 2 v  
 (AC) 229 - 227 = 2 v

Maximum deviation is 2 v.

Determine percent of voltage imbalance

$$\begin{aligned}
 \% \text{ Voltage Imbalance} &= 100 \times \frac{2}{229} \\
 &= 0.8\%
 \end{aligned}$$

This amount of phase imbalance is satisfactory as it is below the maximum allowable 2%.

**IMPORTANT:** If the supply voltage phase imbalance is more than 2%, contact your local electric utility company immediately.

A06564

# CONNECTION WIRING SCHEMATIC 208/230-1-60

## CONNECTION WIRING DIAGRAM

DANGER: ELECTRICAL SHOCK HAZARD DISCONNECT POWER BEFORE SERVICING

SCHEMATIC  
230-1-60

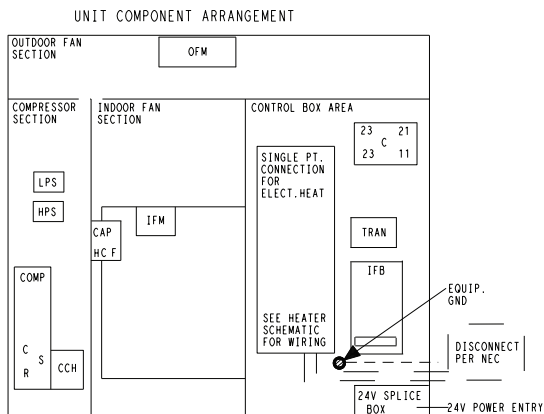
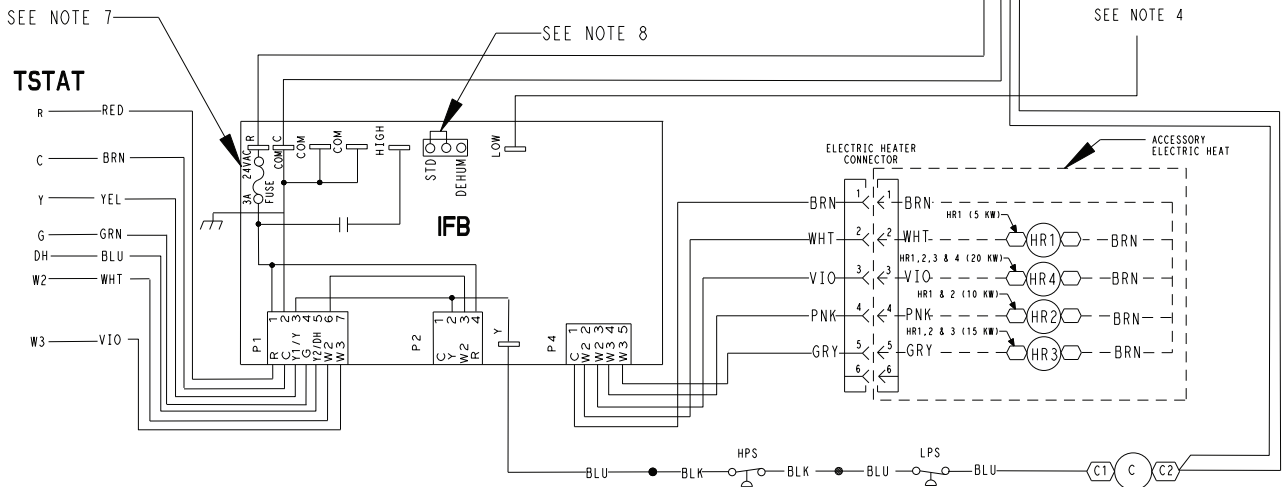
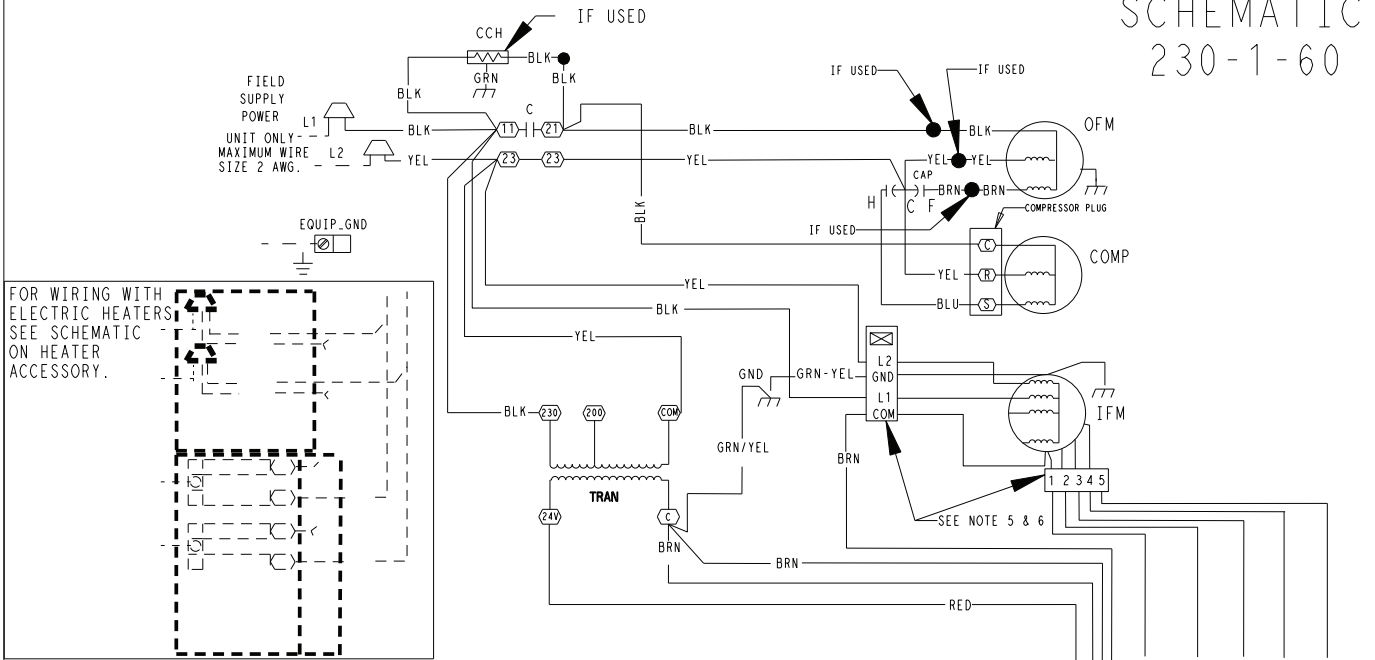

### LEGEND

△	FIELD SPLICE	C	CONTACTOR
○	TERMINAL (MARKED) ENERGIZED	CAP	CAPACITOR
○	TERMINAL (UNMARKED)	CCH	CRANK CASE HEATER
●	SPLICE (IF USED)	COMP	COMPRESSOR MOTOR
○	SPLICE (MARKED)	DEHUM	DEHUMIDIFICATION MODE
—	FACTORY WIRING	GND	GROUND
- - -	FIELD CONTROL WIRING	HPS	HIGH PRESSURE SWITCH
- - -	FIELD POWER WIRING	HR	HEATER RELAY
- - -	ACCESSORY OR OPTIONAL WIRING	IFB	INTERFACE FAN BOARD
—	TO INDICATE COMMON	IFM	INDOOR FAN MOTOR
—	POTENTIAL ONLY:	LPS	LOW PRESSURE SWITCH
—	NOT TO REPRESENT WIRING	OFM	OUTDOOR FAN MOTOR
		STD	STANDARD
		TRAN	TRANSFORMER

### NOTES:

- IF ANY OF THE ORIGINAL WIRES FURNISHED ARE REPLACED, IT MUST BE REPLACED WITH TYPE 90 DEGREE C WIRE OR IT'S EQUIVALENT.
- SEE PRICE PAGES FOR THERMOSTAT AND SUBBASES.
- USE 75 DEGREE COPPER CONDUCTORS FOR FIELD INSTALLATION.
- REFER TO INSTALLATION INSTRUCTIONS FOR CORRECT SPEED SELECTION OF IFM.
- RELOCATION OF SPEED TAPS MAY BE REQUIRED WHEN USING FIELD INSTALLED ELECTRIC HEATERS. CONSULT INSTALLATION INSTRUCTIONS TO DETERMINE CORRECT SPEED TAP SETTING.
- "DO NOT DISCONNECT PLUG UNDER LOAD."
- THIS FUSE IS MANUFACTURED BY LITTELFUSE, P/N 257003.
- UNIT FACTORY-SHIPED IN STD. MODE.

PA4G

# LADDER WIRING SCHEMATIC 208/230-1-60

## LADDER WIRING DIAGRAM

DANGER: ELECTRICAL SHOCK HAZARD DISCONNECT POWER BEFORE SERVICING

PA4G

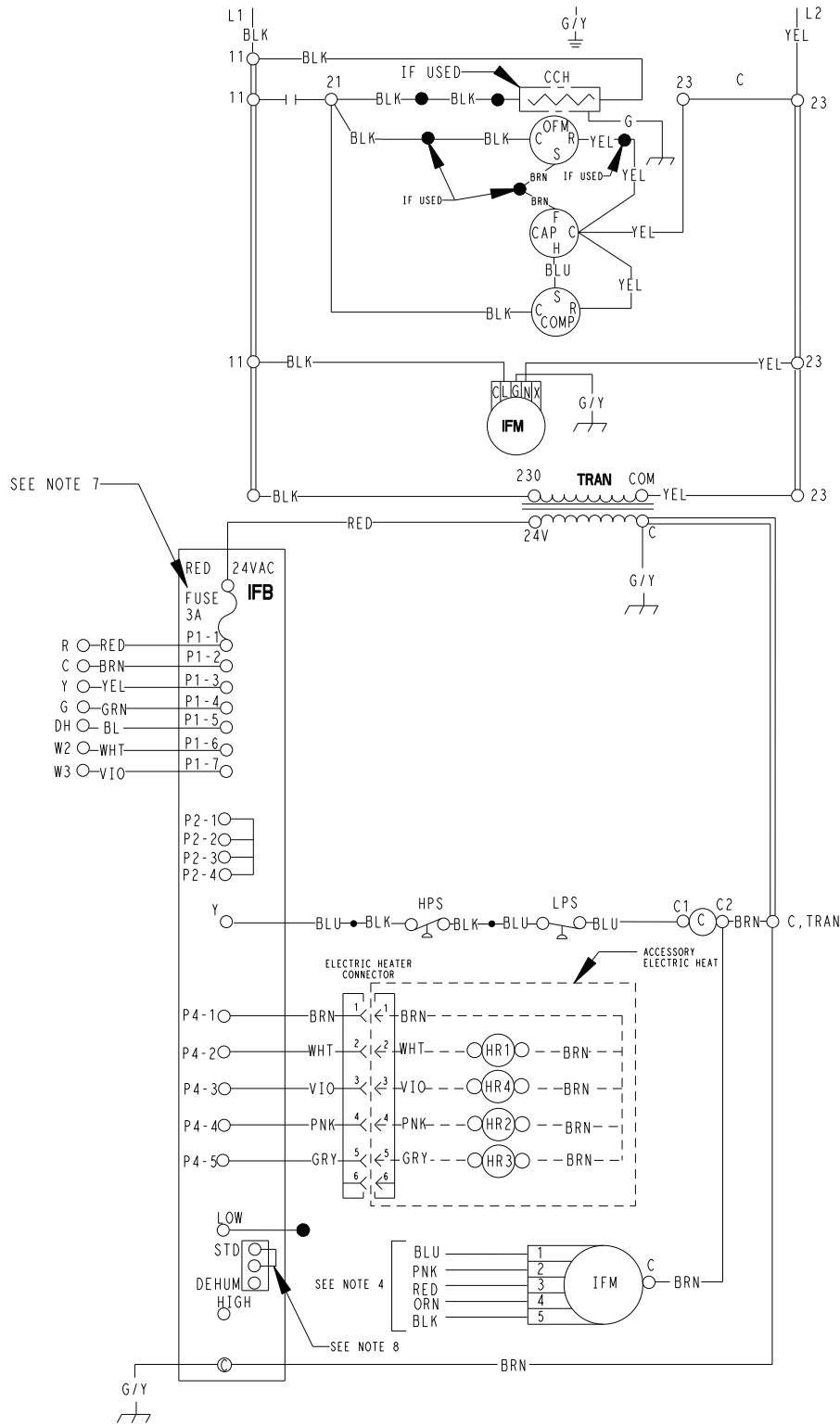

50VL500269

E

A11003

# CONNECTION WIRING SCHEMATIC 208/230-3-60

## CONNECTION WIRING DIAGRAM

DANGER: ELECTRICAL SHOCK HAZARD DISCONNECT POWER BEFORE SERVICING

SCHEMATIC  
230-3-60

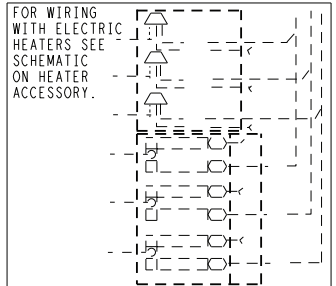
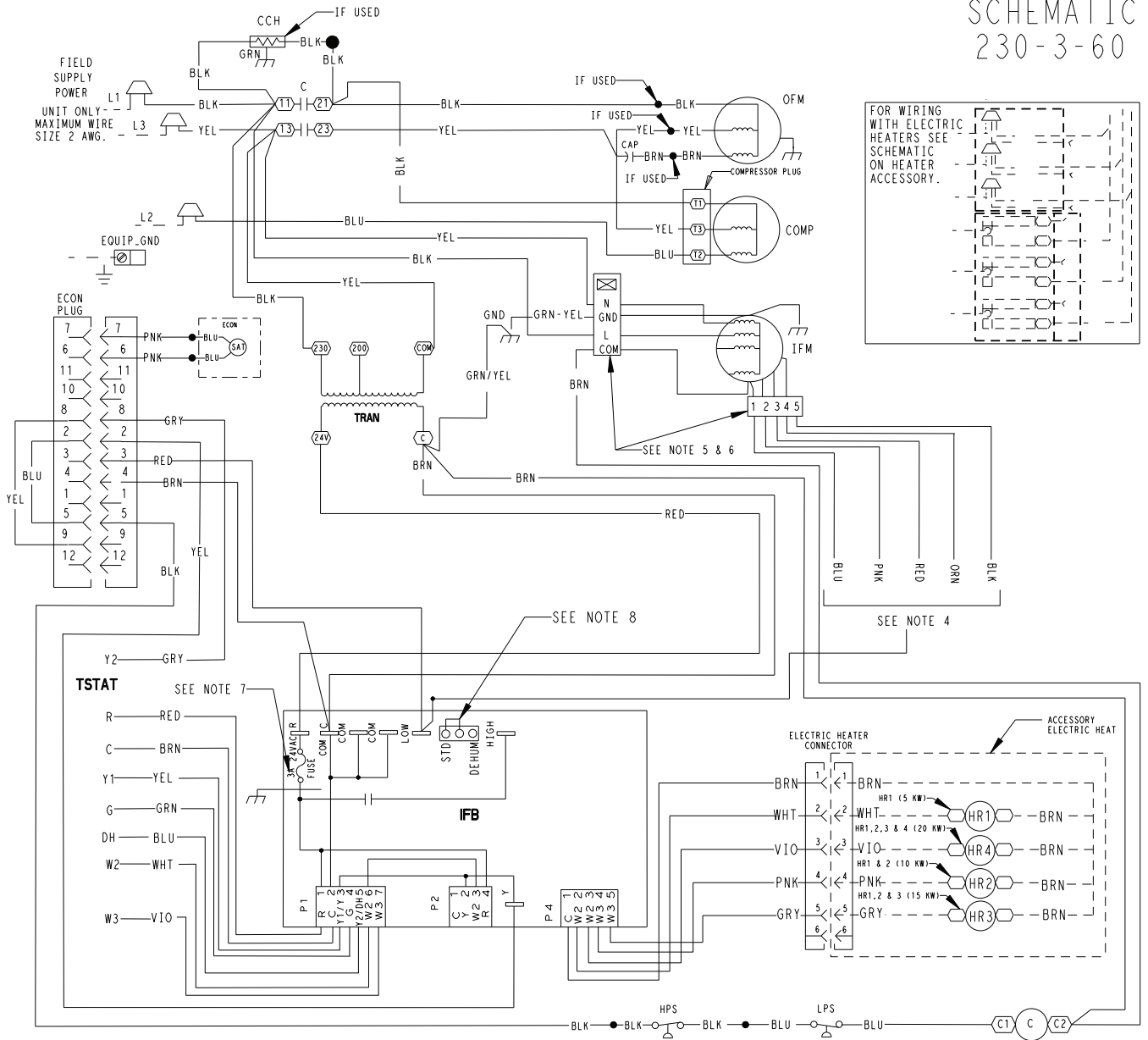

PA4G

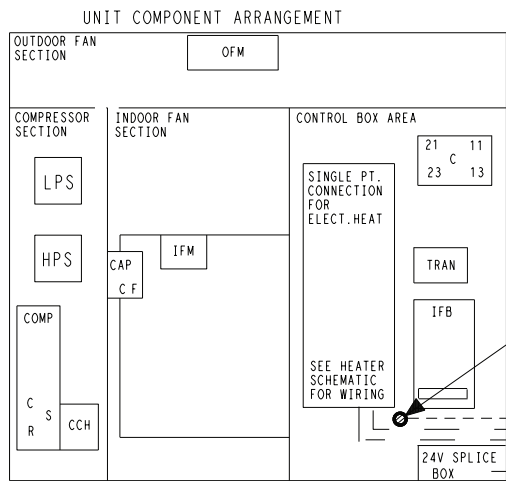

**LEGEND**

△	FIELD SPLICE	C	CONTACTOR
○	TERMINAL (MARKED) ENERGIZED	CAP	CAPACITOR
○	TERMINAL (UNMARKED)	CCH	CRANK CASE HEATER
●	SPLICE (IF USED)	COMP	COMPRESSOR MOTOR
○	SPLICE (MARKED)	DH	DEHUMIDIFICATION MODE
—	FACTORY WIRING	ECON	ECONOMIZER
---	FIELD CONTROL WIRING	GND	GROUND
---	FIELD POWER WIRING	HPS	HIGH PRESSURE SWITCH
---	ACCESSORY OR OPTIONAL WIRING	HR	HEATER RELAY
---	TO INDICATE COMMON	IFB	INTERFACE FAN BOARD
---	POTENTIAL ONLY:	IFM	INDOOR FAN MOTOR
---	NOT TO REPRESENT WIRING	LPS	LOW PRESSURE SWITCH
		OFM	OUTDOOR FAN MOTOR
		STD	STANDARD MODE
		TRAN	TRANSFORMER

- NOTES:**
- IF ANY OF THE ORIGINAL WIRES FURNISHED ARE REPLACED, THEY MUST BE REPLACED WITH THE SAME WIRE OR IT'S EQUIVALENT.
  - SEE PRICE PAGES FOR THERMOSTATS.
  - USE 75 DEGREE COPPER CONDUCTORS FOR FIELD INSTALLATION.
  - REFER TO INSTALLATION INSTRUCTIONS FOR CORRECT SPEED SELECTION OF IFM.
  - RELOCATION OF SPEED TAPS MAY BE REQUIRED WHEN USING FIELD INSTALLED ELECTRIC HEATERS, CONSULT INSTALLATION INSTRUCTIONS TO DETERMINE CORRECT SPEED TAP SETTING.
  - DO NOT DISCONNECT PLUG UNDER LOAD.
  - THIS FUSE IS MANUFACTURED BY LITTELFUSE, P/N 257003
  - DEHUM FEATURE CANNOT BE USED WHEN ECONOMIZER IS INSTALLED. UNIT FACTORY-SHIPED IN STD MODE.

# LADDER WIRING SCHEMATIC 208/230-3-60

## LADDER WIRING DIAGRAM

DANGER: ELECTRICAL SHOCK HAZARD DISCONNECT POWER BEFORE SERVICING

PA4G

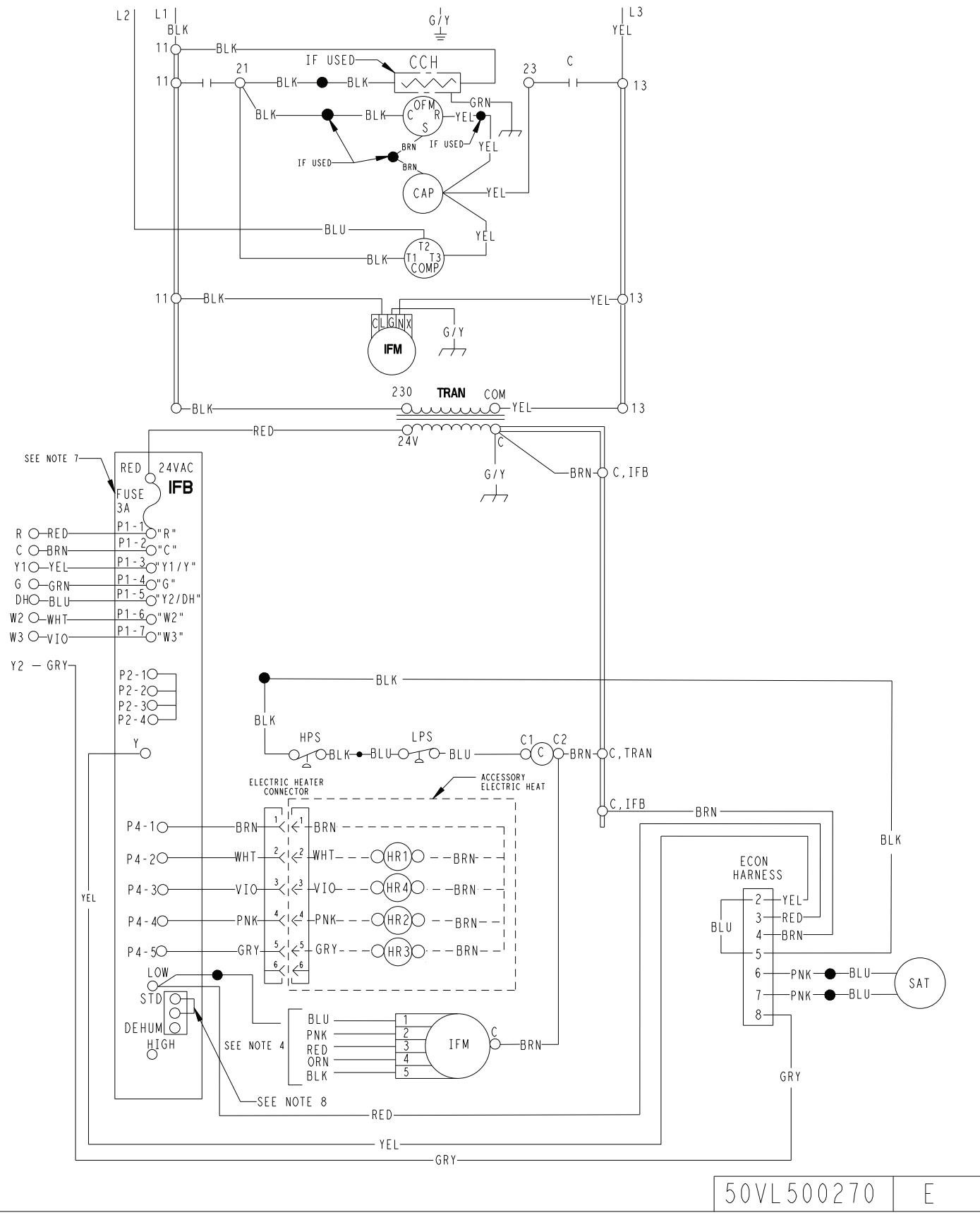

50VL500270

E



# CONNECTION WIRING SCHEMATIC 460-3-60

## CONNECTION WIRING DIAGRAM

DANGER: ELECTRICAL SHOCK HAZARD DISCONNECT POWER BEFORE SERVICING

SCHEMATIC  
460-3-60

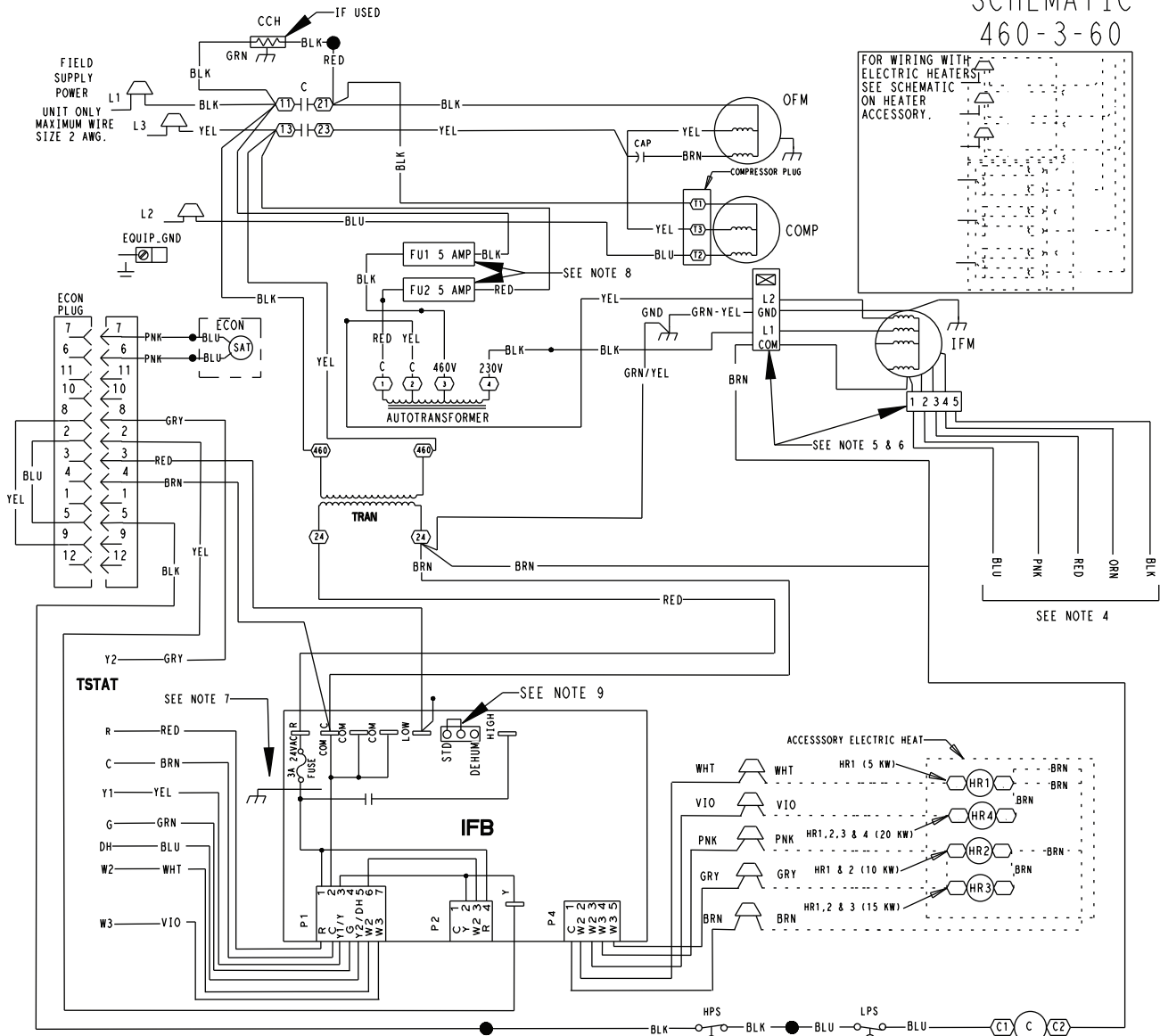

PA4G

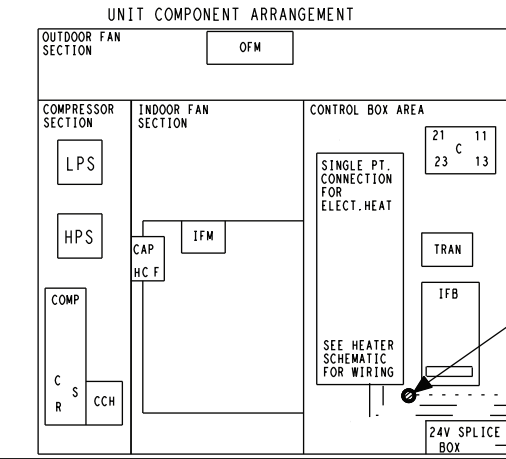

**LEGEND**

△	FIELD SPLICE	C	CONTACTOR
○	TERMINAL (UNMARKED)	CAP	CAPACITOR
●	TERMINAL (MARKED) ENERGIZED	COMP	COMPRESSOR MOTOR
○	SPLICE (IF USED)	DH	DEHUMIDIFICATION MODE
○	SPLICE (MARKED)	DEHUM	DEHUMIDIFICATION MODE
—	FACTORY WIRING	ECON	ECONOMIZER
- - -	FIELD CONTROL WIRING	GND	GROUND
- · - · -	FIELD POWER WIRING	HPS	HIGH PRESSURE SWITCH
- · - · -	ACCESSORY OR OPTIONAL WIRING	HR	HEATER RELAY
—	TO INDICATE COMMON POTENTIAL ONLY: NOT TO REPRESENT WIRING	IFB	INTERFACE FAN BOARD
		IFM	INDOOR FAN MOTOR
		LPS	LOW PRESSURE SWITCH
		OFM	OUTDOOR FAN MOTOR
		STD	STANDARD WIRE
		TRAN	TRANSFORMER

- NOTES:**
- IF ANY OF THE ORIGINAL WIRES FURNISHED ARE REPLACED, IT MUST BE REPLACED WITH TYPE 90 DEGREE C WIRE OR IT'S EQUIVALENT.
  - SEE PRICE PAGES FOR THERMOSTAT AND SUBBASES.
  - USE 75 DEGREE COPPER CONDUCTORS FOR FIELD INSTALLATION.
  - REFER TO INSTALLATION INSTRUCTIONS FOR CORRECT SPEED SELECTION OF IFM.
  - RELOCATION OF SPEED TAPS MAY BE REQUIRED WHEN USING FIELD INSTALLED ELECTRIC HEATERS. CONSULT INSTALLATION INSTRUCTIONS TO DETERMINE CORRECT SPEED TAP SETTING.
  - "DO NOT DISCONNECT PLUG UNDER LOAD."
  - THIS FUSE IS MANUFACTURED BY LITTELFUSE, P/N 257003
  - THESE FUSES ARE MANUFACTURED BY COOPER BUSSMAN, P/N FNO-R-5
  - DEHUM FEATURE CANNOT BE USED WHEN ECONOMIZER IS INSTALLED. UNIT FACTORY-SHIPED IN STD. MODE.

A10204C

# LADDER WIRING SCHEMATIC 460-3-60

## LADDER WIRING DIAGRAM

DANGER: ELECTRICAL SHOCK HAZARD DISCONNECT POWER BEFORE SERVICING

PA4G

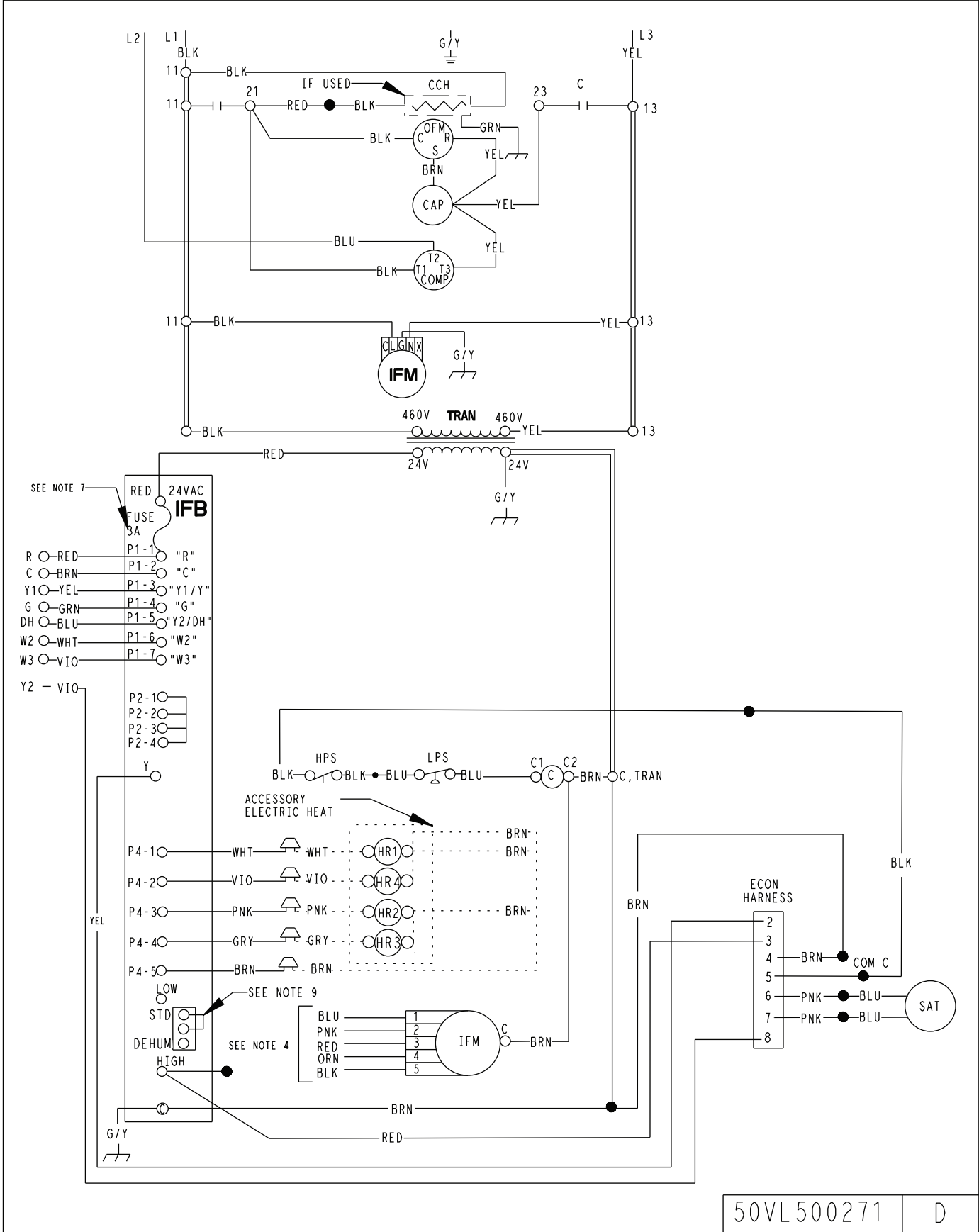

A10204L

## CONTROLS

### Operating sequence

**Cooling** — When the system thermostat calls for cooling, 24 V is supplied to the “Y” and “G” terminals of the thermostat. This completes the circuit to the contactor coil (C) and indoor (evaporator) fan relay (IFR). The normally open contacts of energized C close and complete the circuit through compressor motor (COMP) to outdoor (condenser) fan motor (OFM). Both motors start instantly. The set of normally open contacts of energized IFR close and complete the circuit through IFM. The IFM starts instantly.

On the loss of the thermostat call for cooling, 24 V is removed from both the “Y” and “G” terminals (provided the fan switch is in the “AUTO” position) de-energizing the compressor contactor and opening the contacts supplying power to compressor/OFM. After a 90-second delay, the IFM shuts off. If the thermostat fan selector switch is in the “ON” position, the IFM will run continuously. For the 460 V units there is a step down autotransformer supplying 230 V to the Indoor Fan Motor.

**NOTE:** On units with a Time Guard® II device: Once the compressor has started and then stopped, it cannot be restarted again until 5 minutes have elapsed.

**Heating** — If accessory electric heaters are installed, on a call for heat, circuit R-W is made through the thermostat contacts. Circuit R-G is made which energizes the IFR. If the heaters are staged, then the thermostat closes a second set of contacts (W2) when second stage is required. When thermostat is satisfied, contacts open, deenergizing the heater relay and the IFR.

# GUIDE SPECIFICATIONS

## Packaged Air Conditioner System Constant Volume Application HVAC Guide Specifications

Size Range: **2 to 5 Tons, Nominal Cooling**

### SYSTEM DESCRIPTION

Outdoor rooftop mounted or ground mounted, electric cooling unit utilizing a hermetic scroll compressor for cooling duty. Unit shall discharge supply air vertically or horizontally as shown on contract drawings. Condenser fan/coil section shall have a draw-thru design with vertical discharge for minimum sound levels.

### QUALITY ASSURANCE

- A. Unit shall be rated in accordance with AHRI Standards 210/240 and 270-1995.**
- B. Unit shall be designed in accordance with UL Standard 1995.**
- C. Unit shall be manufactured in a facility registered to ISO 9001 manufacturing quality standard.**
- D. Unit shall be UL listed and c-UL certified as a total package for safety requirements.**
- E. Roof curb shall be designed to conform to NRCA Standards.**
- F. Insulation and adhesives shall meet NFPA 90A requirements for flame spread and smoke generation.**
- G. Cabinet insulation shall meet ASHRAE Standard 62P.**

### DELIVERY, STORAGE AND HANDLING

Unit shall be stored and handled per manufacturer's recommendations.

### Part 2 — Products

#### EQUIPMENT

##### A. General:

Factory-assembled, single-piece, heating and cooling unit. Contained within the enclosure shall be all factory wiring, piping, controls, refrigerant charge with R-410A refrigerant, and special features required prior to field start-up.

##### B. Unit Cabinet:

- 1. Unit cabinet shall be constructed of phosphated, zinc-coated, pre-painted steel capable of with-standing 500 hours in salt spray.
- 2. Normal service shall be through a single removable cabinet panel.
- 3. The unit shall be constructed on a rust proof unit base that has an externally trapped, integrated sloped drain.
- 4. Evaporator fan compartment top surface shall be insulated with a minimum 1/2-in. (12.7 mm) thick, flexible fiberglass insulation, coated on the air side and retained by adhesive and mechanical means. The evaporator wall sections will be insulated with a minimum semi-rigid foil-faced board capable of being wiped clean. Aluminum foil-faced fiberglass insulation shall be used in the entire indoor air cavity section.
- 5. Unit shall have a field-supplied condensate trap.

##### C. Fans:

- 1. The evaporator fan shall be an ECM Motor.
- 2. Fan wheel shall be made from steel, be double-inlet type with forward curved blades with corrosion resistant finish. Fan wheel shall be dynamically balanced.
- 3. Condenser fan shall be direct drive propeller type with aluminum blades riveted to corrosion resistant steel spiders, be dynamically balanced, and discharge air vertically.

##### D. Compressor:

- 1. Fully hermetic compressors with factory-installed vibration isolation.
- 2. Scroll compressors shall be standard on all units.

##### E. Coils:

Evaporator and condenser coils shall have aluminum plate fins mechanically bonded to seamless copper tubes with all joints brazed. Tube sheet openings shall be belled to prevent tube wear.

##### F. Refrigerant Components:

Refrigerant expansion device shall be of the TXV (thermostatic expansion valve) type.

##### G. Filters:

Filter section shall consist of field-installed, throwaway, 1-in. (25 mm) thick fiberglass filters of commercially available sizes.

##### H. Controls and Safeties:

- 1. Unit controls shall be complete with a self-contained low voltage control circuit.
- 2. Compressors shall incorporate a solid-state compressor protector that provides reset capability.

##### I. Operating Characteristics:

- 1. Unit shall be capable of starting and running at 125°F (51°C) ambient outdoor temperature per maximum load criteria of AHRI Standard 210.
- 2. Compressor with standard controls shall be capable of operation down to 40°F (4°C) ambient outdoor temperature.
- 3. Units shall be provided with fan time delay to prevent cold air delivery before the heat exchanger warms up.
- 4. Unit shall be provided with 90-second fan time delay after the thermostat is satisfied.

##### J. Electrical Requirements:

All unit power wiring shall enter the unit cabinet at a single location.

##### K. Motors:

- 1. Compressor motors shall be of the refrigerant-cooled type with line-break thermal and current overload protection.
- 2. All fan motors shall have permanently lubricated bearings, and inherent, automatic reset, thermal overload protection.

##### L. Special Features:

- 1. Coil Options:
  - Base unit with tin plated indoor coil hairpins.
- 2. Compressor Start Kit (single phase units only):
  - Shall provide additional starting torque for single-phase compressors.
- 3. Thermostat:
  - To provide for one-stage heating and cooling in addition manual or automatic changeover and indoor fan control.
- 4. Crankcase Heater:
  - Shall provide anti-floodback protection for low-load cooling applications.
- 5. Economizer:
  - (Horizontal - Field installed accessory)
  - (Vertical - Field installed accessory or factory installed option.)
    - a. Economizer controls capable of providing free cooling using outside air.
    - b. Equipped with low leakage dampers not to exceed 3% leakage, at 1.0 IN. W.C. pressure differential.
    - c. Spring return motor shuts off outdoor damper on power failure.

## GUIDE SPECIFICATIONS (CONT)

6. Electric Heaters:
  - a. Electric heater shall be available as a field-installed option.
  - b. Heater elements shall be open wire type, adequately supported and insulated with ceramic bushings.
  - c. Electric heater packages must provide single point power connection capability.
7. Filter Rack Kit:

Shall provide filter mounting for downflow applications. Offered as an accessory or a factory installed option.
8. Flat Roof Curb:

Curbs shall have seal strip and a wood nailer for flashing and shall be installed per manufacturer's instructions.
9. Low Ambient Package:

Shall consist of a solid-state control and condenser coil temperature sensor for controlling condenser-fan motor operation, which shall allow unit to operate down to 0°F (-17.7°C) outdoor ambient temperature when properly installed.
10. Manual Outdoor Air Damper:

Package shall consist of damper, birdscreen, and rainhood which can be preset to admit outdoor air for year-round ventilation.
11. Square-To-Round Duct Transitions (24-48 size):

Shall have the ability to convert the supply and return openings from rectangular to round.
12. Time Guard II  
Automatically prevents the compressor from restarting for at least 4 minutes and 45 seconds after shutdown of the compressor. Not required when a corporate programmable thermostat is applied or with a RTU-MP control.
13. Dual Point Electric Heaters  
Allows you to power the electric heater and unit contactor separately by having two individual field power supply circuits connected respectively.

