

- Durable polyethylene construction.
- Has funnel top for easy filling.
- Utilizes a metal striking plate to prevent premature fatigue on the pump cap.
- The 3.5 gallon tank holds 3 gallons of solution which provides good capacity without being too big to handle.
- Built-in air pump allows good working pressure to be obtained within moments.
- The extension tube and 5 feet of hose permits reaching difficult areas.
- The spray nozzle gives a complete range of spray patterns.

General Description

The No. 300P Poly Sprayer is constructed of high-density polyethylene. It has a funnel-top which provides easy chemical pouring and has a 3.5 gallon capacity (3 gallon working capacity). It comes with a 10" polypropylene pump, brass handle and extension tube with adjustable nozzle and five feet of wear-resistant hose.

Principal Uses

The No. 300P Poly Sprayer can be used for spraying solutions of CalClean®, Special HD CalClean®, Alka-Brite®, Nu-Brite®, Coil Pow'r® and Evap Pow'r®-C on air conditioning cooling coils, air-cooled condensers, finned heating coils, refrigeration case or cooler coils, permanent air filters and other greasy, dirty surfaces.

Packaging

1 each 4772-0

Main Features

OPERATION

1. Inspect sprayer, and insure the hose is securely attached to the tank and to the shut-off handle.
2. Remove pump assembly from tank by turning counterclockwise.
3. To minimize foaming when preparing cleaning solution, add water to the tank before adding CalClean. Fill tank to fill line on side of tank.

Sprayers

No. 300P Poly Sprayer



4. Close tank by inserting pump assembly through opening. Turn cap right (clockwise) until pump is sealed tightly into the tank (hand-tighten only).
5. Pump plunger to compress air and create pressure in tank. Twenty strokes of plunger provides a good working pressure. As pressure drops during use, recharge with 20 or more pump strokes. More strokes will be needed if the tank is not full, or as the sprayer is used and the pressure drops.
6. Nozzle tip may be adjusted to provide a single needle stream (tip screwed all the way out) or a fine mist (tip screwed all the way in). Spraying time will vary from about 5 minutes with the needle spray to about 12-15 minutes with the fine mist. The needle spray should be used on finned coils to reach the third and fourth banks better. Mist is better for cleaning permanent filters.
7. Allow cleaning solution to remain in contact with dirty surfaces for about 15 minutes, then flush with water from a hose. If a hose is not available, fill sprayer with water and flush using a course spray.

Relieving Pressure

1. To minimize foaming when cleaning solution, add water to the tank before adding CalClean. Fill tank to fill line on side of tank.
2. Close tank by inserting pump assembly through opening. Turn cap right (clockwise) until pump is

sealed tightly into the tank (hand-tighten only).

NOTE: Never stand with head or body over pump when operating or removing pump. If pump does not turn freely when removing, make sure there is no pressure in tank.

Care for Sprayer

1. Do not leave solution in tank after using
2. After using, rinse with clear water and drain completely.
3. Store upside down in a dry place. Remove pump and hang up separately.
4. Pump works easier and faster if you oil it occasionally. Squirt any clean oil through opening around pump rod.

Troubleshooting

If you cannot build up pressure:

Remove pump. Hold rubber check valve on end of pump closed and operate pump. If little or no resistance is felt on down stroke, the plunger cup or its check valve are probably at fault. Pull plunger cup to top of cylinder and squirt a little clean oil onto the cylinder wall and edge of cup. If this does not correct the problem, unscrew (counterclockwise) the pump cap from the top of the pump cylinder. Pull out plunger

assembly and inspect cup for scoring, cracking, or dirt under cup check valve. To replace plunger cup, unscrew old cup and screw new cup on until top of cup just touches bump on side of rod. Check that rod has not entered cup so far that is pushing check valve out of cup. Inspect pump cylinder gasket and check valve for damage or dirt. Carefully insert plunger assembly into cylinder. Fit the notches of the cam plate into the notches on top of the pump cylinder, then screw the pump cap onto pump cylinder.

If shut-off leaks:

Leaks at threads can be cured by further tightening or sealing with pipe joint compound. For other leaks or failure to shut off properly, disassemble and check for dirt or damage to seals and spring.

Incorrect spray pattern:

This is almost always caused by dirt inside nozzle. After long use, nozzle cap may wear and should be replaced if necessary.

Read and understand the product's label and Material Safety Data Sheet ("MSDS") for precautionary and first aid information.

The MSDS is available on the Nu-Calgon website at www.nucalgon.com.

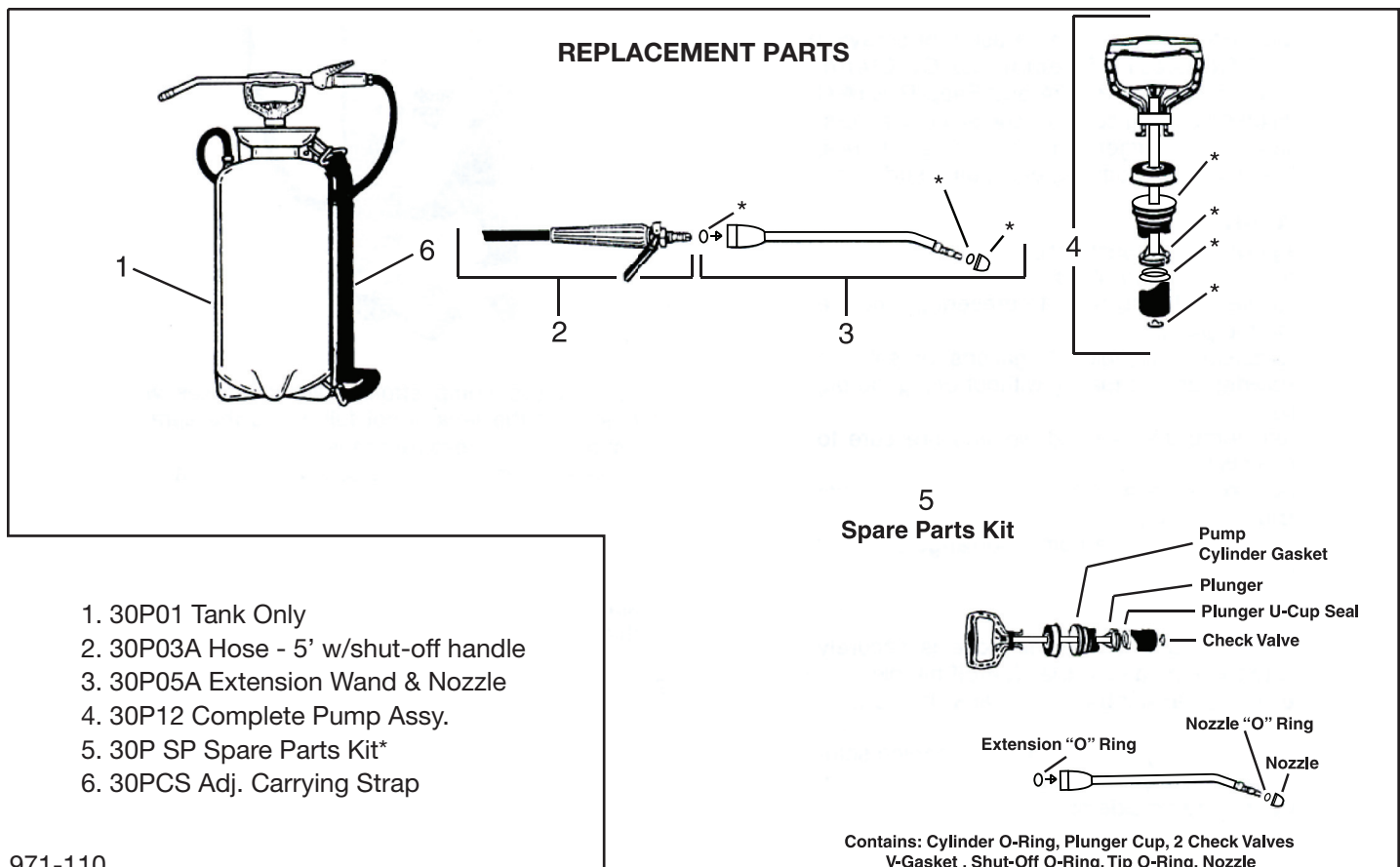

971-110

