

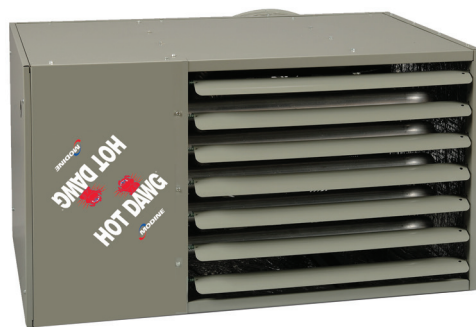

GAS-FIRED SEPARATED COMBUSTION UNIT HEATERS



MODEL HDS



MODEL HDC



MODEL PTS / BTS

TABLE OF CONTENTS



Modine's separated combustion unit heaters are designed for the heating requirements of commercial and industrial buildings with select models available for residential garage heating as well. The separated combustion units draw combustion air from outside to ensure that the unit will always have plenty of fresh, clean air for combustion, reducing common concerns about dusty, dirty, humid, or negative space pressure applications. In addition, by drawing the combustion air from the outside, the overall heating efficiency is increased.

With 13 propeller and 11 blower model sizes available, the units cover a wide variety of applications with input ranges from 30,000 to 400,000 Btu/Hr in either natural or propane gas. This catalog describes the design benefits, construction features, performance data, unit selection procedure, and the optional and accessory devices available.

Table of Contents

Page

Design Features - All Models	3-5
General Performance Data - Propeller Models HDS/PTS	6
General Performance Data - Blower Models HDC/BTS	7
Blower Performance Data - Blower Model HDC	8
Blower Performance Data - Blower Model BTS	9-11
Gas Control Data - All Models	12
Field Installed Accessories	13
Downturn Hood Performance Data - Propeller Models HDS/PTS	14
Downturn Hood Performance Data - Blower Model HDC/BTS	15
Unit Selection	16-17
Dimensional Data - Models HDS/HDC	18
Dimensional Data - Model PTS	19
Dimensional Data - Model BTS	20
Specifications - All Models	21-22
Model Nomenclature - All Models	23

! WARNING
Do not locate ANY gas-fired unit in areas where chlorinated, halogenated or acid vapors are present in the atmosphere.

! WARNING
Appliances must not be installed where they may be exposed to a potentially explosive or flammable atmosphere.

As Modine Manufacturing Company has a continuous product improvement program, it reserves the right to change design and specifications without notice.



The Modine Breeze® AccuSpec is the fastest way to generate performance data based on actual job conditions. The Breeze® AccuSpec program is a web-based sizing and selection program. The program provides a series of step-by-step questions that allow for the easy configuration of Modine products. After a model has been configured, the program can generate Submittal Schedules, Submittal Data (including performance and dimensional drawings), and Specifications.

DESIGN FEATURES - ALL MODELS



Separated Combustion Unit Heaters, 30-125MBH

For residential, commercial or industrial applications that require a low profile unit, Modine offers the Hot Dawg®. Capable of being installed just one inch below the ceiling, the superior quality of the Hot Dawg makes it a preferred choice for a variety of applications, including garages and workshops.

Separated Combustion Unit Heaters, 150-400MBH

For commercial or industrial applications that require higher input ratings, the PTS/BTS is available in ratings that range from 150,000 to 400,000 Btu/Hr in either natural or propane gas.

Figure 3.1 - Hot Dawg Propeller Unit Heater



Figure 3.2 - Hot Dawg Blower Unit Heater

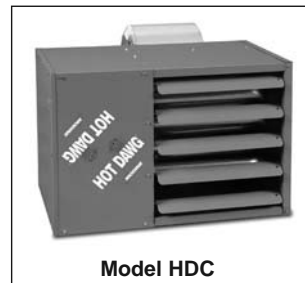

Figure 3.3 - Propeller Unit Heater

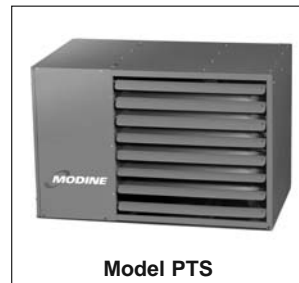

Figure 3.4 - Blower Unit Heater

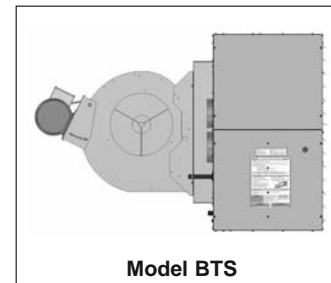
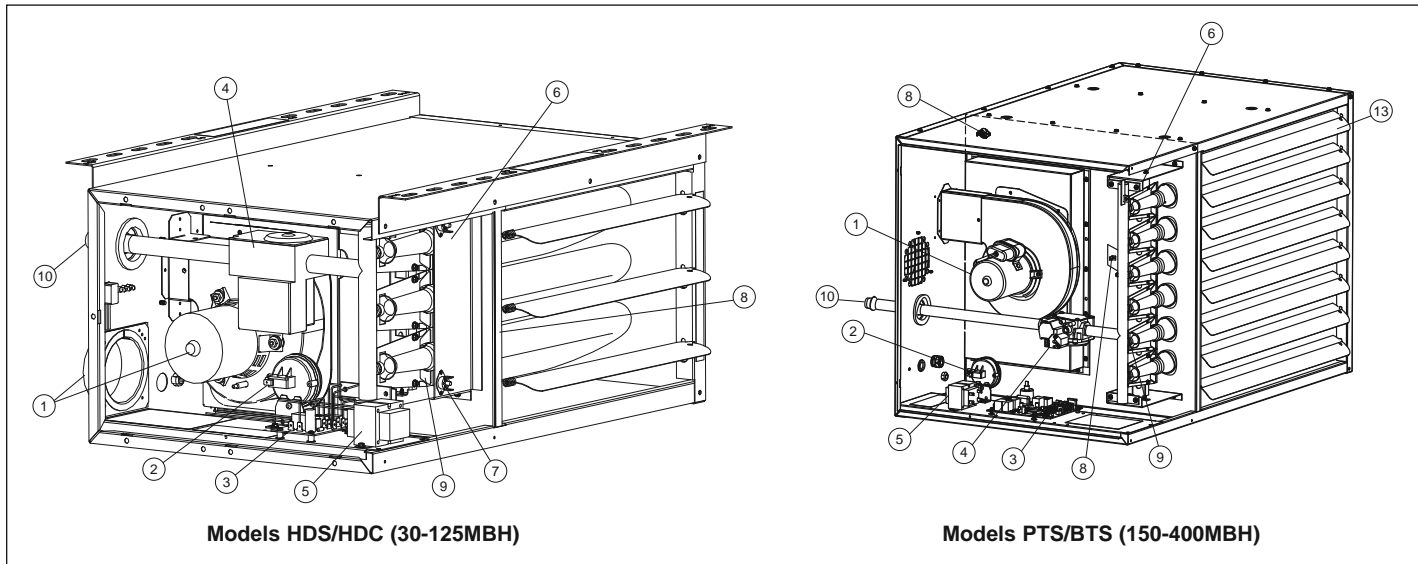

Table 3.1 - Standard Features and Factory Options ①

	Feature	Model			
		HDS	HDC	PTS	BTS
Cabinet and Air Mover	Aluminized steel cabinet (gauge indicated)	22 ga.	22 ga.	20 ga.	20 ga.
	Low profile casing design	•	•		
	Baked-on polyester powder paint for durability and corrosion resistance	•	•	•	•
	Adjustable air-deflector blades	•	•	•	•
	Fans engineered for quiet operation	•	•	•	•
	Totally enclosed fan/blower motors for maximum durability (model sizes 100 and above)	•		•	•
	Fingerproof fan guard (optional on PTS units)	•	•	•	
	Two L-shaped mounting brackets (optional on sizes 100/125)	•	•		
	Multi-tap 3-speed motors, certified to 0.8" W.C. external static pressure		•		
	Adjustable motor sheaves, certified to 0.7" W.C. external static pressure				•
Heat Exchanger and Burner	82% thermally efficient	•	•	•	•
	Aluminized steel heat exchanger (409 stainless steel optional)	•	•	•	•
	Tubular heat exchanger for superior durability	•	•	•	•
	In-shot burner on each heat exchanger tube for reliable performance, ease of serviceability and low sound level on flame ignition/extinction	•	•	•	•
Controls	ETL certification for commercial and industrial use in the US and Canada	•	•	•	•
	ETL certification for residential use in the US and Canada	•	•		
	Factory-installed power exhauster	•	•	•	•
	Controls for natural gas (propane optional)	•	•	•	•
	Single stage gas controls (two stage optional)	•	•	•	•
	High limit safety control	•	•	•	•
	Differential pressure switch for proof of venting	•	•	•	•
	Flame roll-out safety switch	•	•		
	Direct spark ignition with continuous retry control system	•	•	•	•
	Control terminal board and low voltage terminal connections	•	•	•	•
	Gas control step down transformer with 24V gas controls	•	•	•	•
Fan delay timer	•	•	•	•	

① See page 13 for Field Installed Accessories

Figure 4.1 - Factory Mounted Standard and Optional Features



① **Power Exhauster (STD)**

All units are supplied with a round vent pipe and combustion air inlet pipe connections.

② **Pressure Switch (STD)**

An automatic reset vent pressure switch is supplied on all units and is designed to prevent operation of the main burner in the event there is restricted venting of flue products. This restriction may occur due to an improper vent diameter, long vent runs, un-approved vent terminal, high winds, high negative pressure within space, etc. After the cause of the restriction has been corrected, the pressure switch will reset automatically.

③ **Integrated Direct Spark Control Board (STD)**

The integrated direct spark ignition control combines all furnace control functions. The integrated board provides digital control of the air mover, inducer, ignition, gas valve and flame sense as well as monitoring the safety circuit at all times. The board includes LED diagnostics for trouble shooting and a fused power supply.

④ **Gas Valve - (See Table 12.2)**

a) **Single Stage Gas Valve - (STD)**

The main gas valve is factory installed on the unit heater gas train. The main gas valve provides regulator, main gas, and manual shutoff functions. The valve is redundant and provides 100% shut off.

b) **Two Stage Gas Valve - (OPT)**

The two-stage gas valve is factory installed on the unit heater gas train. The two stage gas valve provides the regulator, main gas (100% and 50% fire), and manual shutoff functions. The valve is redundant and provides 100% shut off.

⑤ **Control Step Down Transformer - (STD)**

The control step down transformer is located in the electrical junction box. The transformer is used to step down from 115V to 24V for the gas controls, fan delay relay, field supplied motor starter, etc. An additional field installed transformer is required if the supply voltage is 208V, 230V, 460V, or 575V. To determine the control transformer supplied as well as any accessory/field supplied transformers required, refer to Table 12.1

⑥ **Flame Sensor (hidden) - (STD)**

Remote flame sensor verifies ignition of all burners, monitors the flame signal and communicates with the integrated circuit board.

⑦ **Flame Roll Out Switch (HDS/HDC models only) - (STD)**

Flame roll out switches are mounted near the burners and will shut off the gas supply in the event of an unsafe flame roll out condition.

⑧ **High Limit Switch (hidden) - (STD)**

The limit control is mounted in the air stream and will shut off the gas supply in the event of overheating.

⑨ **Direct Spark Igniter (hidden) - (STD)**

Provides spark for direct ignition of the burners.

⑩ **Gas Pipe Connection - (STD)**

Easy access to factory installed gas pipe connection stubbed to outside of unit casing.

Figure 5.1 - Factory Mounted Standard and Optional Features

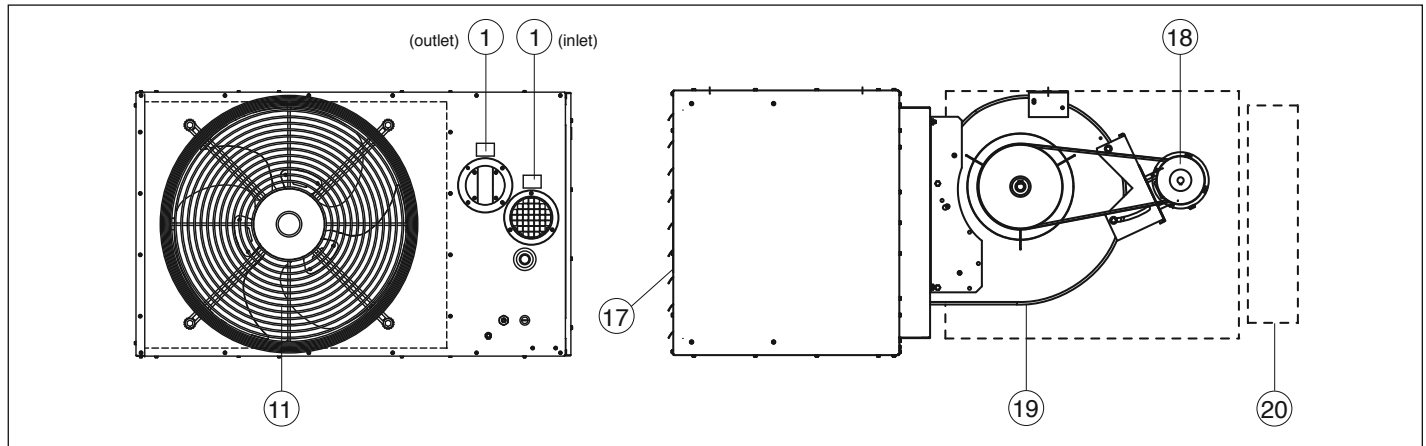

⑪ Finger Proof Fan Guard (STD thru 125, OPT 150-400)

Propeller units may be equipped with an optional finger proof fan guard for added protection. The finger proof fan guard is installed at the factory in place of the standard fan guard.

⑫ Blower Motor - (STD for HDC/BTS Models)

The blower motor is factory installed on the blower housing. Blower motors smaller than 3 HP are factory installed on the blower housing. Motors 3 HP and above are shipped loose for field installation to prevent damage during shipment. For blower models 60-125, the blower is direct driven by a 3-speed motor. For blower models 150-400, the blower motor is supplied with an adjustable sheave that can be used to increase/decrease the blower RPM, and the blower motor can be provided in a variety of supply voltages and motor horsepowers.

⑬ Horizontal Air Deflector Blades (STD)

Factory mounted on the discharge of the unit, the blades can be adjusted to provide horizontal (up and down) delivery control of the heated air. Vertical deflector blades are available as a field installed accessory.

⑭ Blower Enclosure (OPT for HDC/BTS Models)

⑮ Filter Rack (OPT for HDC/BTS Models)

Provides filtration of air to be heated. Must include Blower Enclosure accessory.

GENERAL PERFORMANCE DATA - MODELS HDS & PTS



Table 6.1 - Propeller Unit Model HDS and PTS General Performance Data

	Model HDS Sizes						Model PTS Sizes						
	30	45	60	75	100	125	150	175	200	250	300	350	400
Btu/Hr Input ①	30,000	45,000	60,000	75,000	100,000	125,000	150,000	175,000	200,000	250,000	300,000	350,000	400,000
Btu/Hr Ouput ①	24,600	36,900	49,200	61,500	82,000	102,500	123,000	143,500	164,000	205,000	246,000	287,000	328,000
Entering Airflow (CFM) @ 70°F	505	720	990	1160	1490	1980	2140	2725	2870	3995	4545	5280	5995
Outlet Velocity (FPM)	523	725	653	769	565	747	711	607	643	721	824	748	851
Air Temp. Rise (°F)	44	46	45	48	50	47	53	48	52	47	50	50	51
Max. Mounting Height (Ft.) ②	10	10	12	14	12	16	15	14	15	18	19	18	21
Heat Throw (Ft.) @ Max Mtg Ht ②	25	27	36	38	42	56	51	50	53	62	69	65	74
Motor Type ③	SP	SP	PSC	PSC	SP	PSC	PSC	PSC	PSC	PSC	PSC	PSC	PSC
Motor HP	1/15	1/15	1/12	1/12	1/12	1/8	1/6	1/6	1/3	1/3	1/2	1/2	3/4
Motor RPM	1550	1550	1625	1625	1050	1625	1075	1075	1075	1075	1075	1125	1125

① Ratings shown are for elevations up to 2,000 ft. For elevations above 2,000 feet, ratings should be reduced at the rate of 4% for each 1,000 feet above sea level. (In Canada see rating plate.) Reduction of ratings requires use of a high altitude kit.

② Data taken at 55°F air temperature rise. At 65°F ambient and unit fired at full-rated input. Mounting height as measured from bottom of unit, and without deflector hoods.

③ All motors used are produced, rated and tested by reputable manufacturers in accordance with NEMA standards and carry the standard warranty of both the motor manufacturer and Modine. Motors on model sizes 100 and above are totally enclosed (Model size 75 and below are open drip proof) and all single phase motors have built in thermal overload protection.

Table 6.2 - Propeller Unit Model HDS and PTS Operating Electrical Data ④

Supply Voltage	Power Code		Model HDS Sizes						Model PTS Sizes						
			30	45	60	75	100	125	150	175	200	250	300	350	400
115V 1 Phase	01 (115V)	Motor Amps	2.40	2.40	1.95	1.95	2.50	2.20	2.50	2.50	4.60	4.60	7.00	7.00	8.80
		Total Amps	3.75	3.75	3.3	3.3	5.05	4.75	5.05	5.05	7.15	7.15	8.11	8.65	10.45
		Transformer kVA	n/a	n/a	n/a	n/a	n/a	n/a	n/a	n/a	n/a	n/a	n/a	n/a	n/a
208V 1 Phase	01 (115V) with Transformer	Transformer kVA	0.50	0.50	0.50	0.50	1.00	1.00	1.00	1.00	1.00	1.00	1.00	1.00	1.50
		208V Total Amps	2.05	2.05	1.80	1.80	2.79	2.63	2.79	2.79	4.20	3.95	4.48	4.78	5.78
230V 1 Phase	01 (115V) with Transformer	Transformer kVA	0.50	0.50	0.50	0.50	0.75	0.75	0.75	0.75	1.00	1.00	1.00	1.00	1.50
		230V Total Amps	1.85	1.85	1.63	1.63	2.53	2.38	2.53	2.53	3.80	3.58	4.06	4.33	5.23
208V 3 Phase	01 (115V) with Transformer	Transformer kVA	0.50	0.50	0.50	0.50	1.00	1.00	1.00	1.00	1.00	1.00	1.00	1.00	1.50
		208V Total Amps	2.05	2.05	1.80	1.80	2.79	2.63	2.79	2.79	4.20	3.95	4.48	4.78	5.78
230V 3 Phase	01 (115V) with Transformer	Transformer kVA	0.50	0.50	0.50	0.50	0.75	0.75	0.75	0.75	1.00	1.00	1.00	1.00	1.50
		230V Total Amps	1.85	1.85	1.63	1.63	2.53	2.38	2.53	2.53	3.80	3.58	4.06	4.33	5.23
460V 3 Phase	01 (115V) with Transformer	Transformer kVA	0.50	0.50	0.50	0.50	0.75	0.75	0.75	0.75	1.00	1.00	1.00	1.00	1.50
		460V Total Amps	0.93	0.93	0.81	0.81	1.26	1.19	1.26	1.26	1.90	1.79	2.03	2.16	2.61
575V 3 Phase	01 (115V) with Transformer	Transformer kVA	0.50	0.50	0.50	0.50	0.50	0.50	0.50	0.50	0.50	0.50	0.50	0.50	0.50
		575V Total Amps	0.74	0.74	0.65	0.65	1.01	0.95	1.01	1.01	1.52	1.43	1.62	1.73	2.09

④ Amp draw data shown is operating amp draw at incoming power. For units that use a field installed accessory step-down transformer as noted, the amp draw shown is the primary side operating amp draw. For sizing of circuit protection for equipment with transformers, please refer to the National Electric Code.

GENERAL PERFORMANCE DATA - MODELS HDC & BTS



Table 7.1 - Blower Unit Model HDC and BTS General Performance Data

	Model HDC Sizes				Model BTS Sizes						
	60	75	100	125	150	175	200	250	300	350	400
Btu/Hr Input ①	60,000	75,000	100,000	125,000	150,000	175,000	200,000	250,000	300,000	350,000	400,000
Btu/Hr Output ①	49,200	61,500	82,000	102,500	123,000	143,500	164,000	205,000	246,000	287,000	328,000
Entering Airflow Range (CFM)	635-1111	794-1389	1140-2116	1235-2058	1587-2778	1852-3241	2116-3704	2646-4630	3175-5556	3704-6481	4233-7407
Outlet Velocity (FPM)	437-726	546-908	443-781	488-773	543-903	428-711	489-813	497-826	596-991	543-903	621-1032
Air Temp. Rise (°F)	40-70	40-70	35-65	45-75	40-70	40-70	40-70	40-70	40-70	40-70	40-70
Max. Mounting Height (Ft.) ②	7-13	7-16	8-19	8-17	9-21	8-18	9-21	10-22	11-26	11-26	13-29
Heat Throw (Ft.) @ Max Mtg Ht ②	20-45	24-57	27-68	27-59	33-75	28-65	32-74	34-78	40-94	39-90	44-102
Motor Type ③	P.S.C.	P.S.C.	P.S.C.	P.S.C.	T.E	T.E	T.E	T.E	T.E	T.E	T.E
Motor HP	1/4	1/3	1/2	1/2	See Table 9.1						
Motor RPM	Max 1100	Max 1100	Max 1100	Max 1100	1725	1725	1725	1725	1725	1725	1725

Table 7.2 - Blower Unit Model HDC and BTS Operating Electrical Data

Supply Voltage	Power Code		Model HDC Sizes				Model BTS Sizes						
			60	75	100	125	150	175	200	250	300	350	400
115V 1 Phase	01 (115V)	Motor Amps	5.70	7.10	9.50	9.50	See Tables 7.3 through 7.5						
		Total Amps	7.05	8.45	12.05	12.05							
		Transformer kVA	n/a	n/a	n/a	n/a							
208V 1 Phase	01 (115V) with Transformer	Transformer kVA	1.00	1.00	1.50	1.50							
		208V Total Amps	3.87	4.64	6.66	6.66							
230V 1 Phase	01 (115V) with Transformer	Transformer kVA	1.00	1.00	1.50	1.50							
		230V Total Amps	3.50	4.20	6.03	6.03							
208V 3 Phase	01 (115V) with Transformer	Transformer kVA	1.00	1.00	1.50	1.50							
		208V Total Amps	3.87	4.64	6.66	6.66							
230V 3 Phase	01 (115V) with Transformer	Transformer kVA	1.00	1.00	1.50	1.50							
		230V Total Amps	3.50	4.20	6.03	6.03							
460V 3 Phase	01 (115V) with Transformer	Transformer kVA	1.00	1.00	1.50	1.50							
		460V Total Amps	1.75	2.10	3.01	3.01							
575V 3 Phase	01 (115V) with Transformer	Transformer kVA	1.00	1.00	1.50	1.50							
		575V Total Amps	1.40	1.68	2.41	2.41							

Table 7.3 - Blower Model BTS Motor Amp Draw ④ ⑤

Motor HP	Supply Voltage					
	115V/1ph	230V/1ph	208V/3ph	230V/3ph	460V/3ph	575V/3ph
1/4	3.70	-	-	-	-	-
1/3	5.00	2.50	1.10	1.10	0.60	0.60
1/2	7.20	3.60	2.10	2.20	1.10	0.80
1	12.00	6.00	3.20	3.20	1.60	1.30
1-1/2	15.00	7.50	4.60	4.80	2.40	1.90
2	-	-	6.00	5.80	2.90	2.30
3	-	-	8.40	7.80	3.90	3.20
5	-	-	13.60	12.30	6.20	5.10

Table 7.4 - Blower Model BTS Control Circuit Amp Draw ④ ⑤

Model Size	Supply Voltage					
	115V/1ph	230V/1ph	208V/3ph	230V/3ph	460V/3ph	575V/3ph
150-250	2.55	1.28	1.41	1.28	0.64	0.51
300	1.11	0.56	0.61	0.56	0.28	0.22
350-400	1.65	0.83	0.91	0.83	0.41	0.33

Table 7.5 - Blower Model BTS Accessory Transformer Size (kVA) ⑥

Model Size	Supply Voltage			
	208V	230V	460V	575V
	3 ph	1 or 3 ph	3 ph	3 ph
150-250	0.50	0.50	0.50	0.50
300-400	0.50	0.25	0.25	0.25

① Ratings shown are for elevations up to 2,000 ft. For elevations above 2,000 feet, ratings should be reduced at the rate of 4% for each 1,000 feet above sea level. (In Canada see rating plate.) Reduction of ratings requires use of a high altitude kit.

② Data taken at 55°F air temperature rise. At 65°F ambient and unit fired at full-rated input. Mounting height as measured from bottom of unit, and without deflector hoods.

③ All motors used are produced, rated and tested by reputable manufacturers in accordance with NEMA standards and carry the standard warranty of both the motor manufacturer and Modine. Model HDC motors are open drip proof, while model BTS motors are totally enclosed and all single phase motors have built-in thermal overload protection.

④ Amp draw data shown is operating amp draw at incoming power. For units that use a field installed accessory step-down transformer as noted, the amp draw shown is the primary side operating amp draw. For sizing of circuit protection for equipment with transformers, please refer to the National Electric Code.

⑤ For BTS models, add the Motor Amp Draw and Control Circuit Amp Draw to get the Total Unit Amp Draw.

⑥ Transformers for blower models are typically smaller than those used for propeller models, as the transformer is not needed for the blower motor. Size 300-400 use a PSC power exhaustor motor, further reducing the required transformer size.



Table 8.1 - Power Code Description - HDC Models

Power Code	Unit Voltage	HDC60	HDC75	HDC100	HDC125
01	115/60/1	1/4 HP	1/3 HP	1/2 HP	1/2 HP

**Blower Speed Curves
Models (HDC 60-125)**

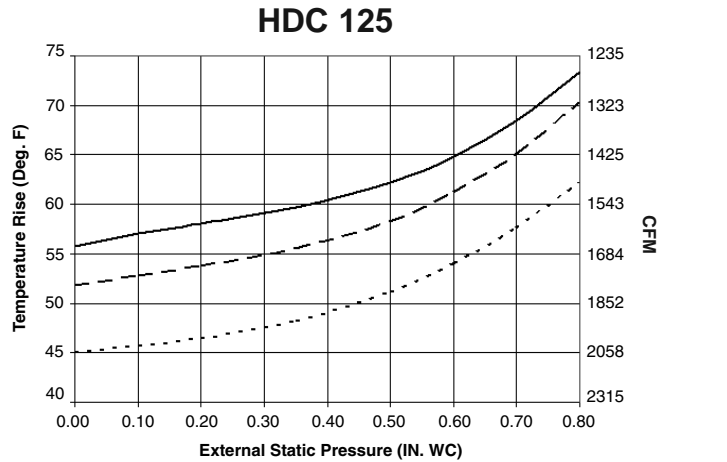
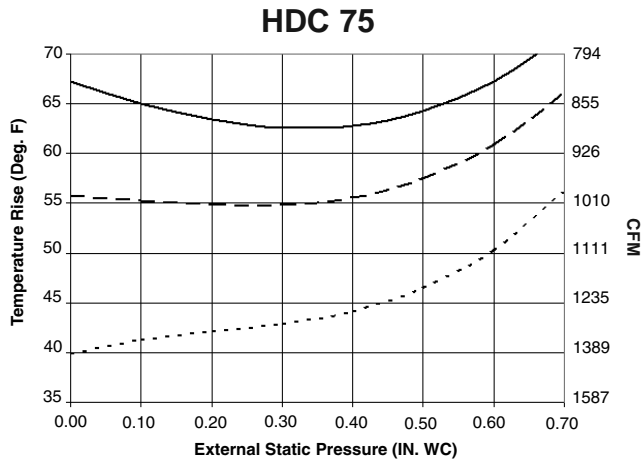
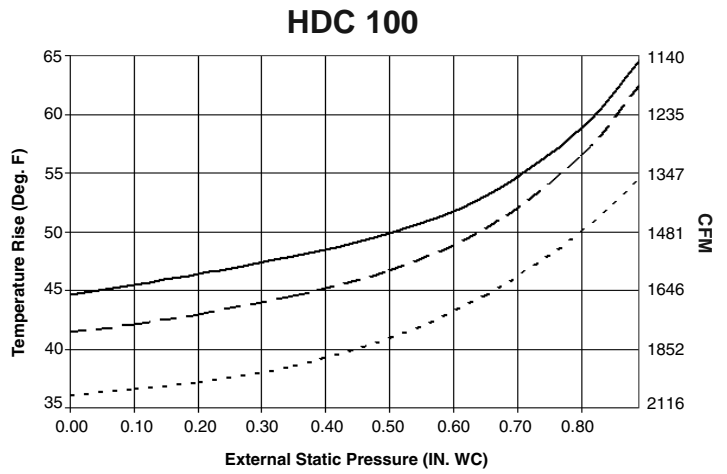
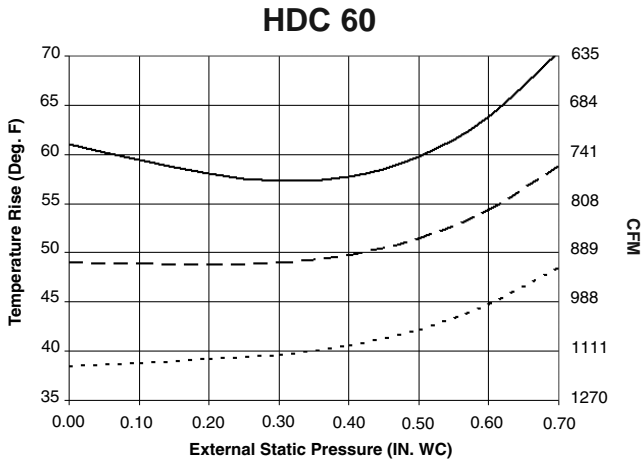

BLOWER PERFORMANCE DATA - MODEL BTS



Table 9.1 - Power Code Description - Blower Model BTS ①

Power Code	Voltage	Phase	BTS150		BTS175		BTS200		BTS250		BTS300		BTS350		BTS400	
			HP	Drive	HP	Drive	HP	Drive	HP	Drive	HP	Drive	HP	Drive	HP	Drive
01	115	1	1/4	230	-	-	-	-	-	-	-	-	-	-	-	-
02	115/230	1	1/3	230	1/3	238	1/2	233	1/2	204	1	240	1 1/2	250	1 1/2	247
08	208-230/460	3	1/3	230	1/3	238	1/2	233	1/2	204	1	257	1 1/2	251	1 1/2	248
11	575	3	1/3	231	1/3	239	1/2	233	1/2	204	1	257	1 1/2	251	1 1/2	248
13	115/230	1	1/3	232	1/2	229	1	229	1	241	1	241	1 1/2	247	-	-
19	208-230/460	3	1/3	232	1/2	229	1	259	1	258	1	258	1 1/2	248	2	177
22	575	3	1/3	233	1/2	229	1	259	1	258	1	258	1 1/2	248	2	177
24	115/230	1	1/2	229	1	175	1	175	1.5	23	1 1/2	243	1 1/2	252	-	-
30	208-230/460	3	1/2	229	1	253	1	253	1.5	177	1 1/2	244	1 1/2	180	3	246
33	575	3	1/2	229	1	253	1	253	1.5	177	1 1/2	244	1 1/2	180	3	246
35	115/230	1	1	175	1 1/2	237	1 1/2	235	-	-	1 1/2	23	-	-	-	-
41	208-230/460	3	1	253	1 1/2	234	1 1/2	236	2	180	1 1/2	177	2	177	5	245
44	575	3	1	253	1 1/2	234	1 1/2	236	2	180	1 1/2	177	2	177	5	245
52	208-230/460	3	-	-	-	-	-	-	-	-	2	177	2	180	-	-
55	575	3	-	-	-	-	-	-	-	-	2	177	2	180	-	-
63	208-230/460	3	-	-	-	-	-	-	-	-	3	112	3	246	-	-
66	575	3	-	-	-	-	-	-	-	-	3	112	3	246	-	-
74	208-230/460	3	-	-	-	-	-	-	-	-	-	-	5	245	-	-
77	575	3	-	-	-	-	-	-	-	-	-	-	5	245	-	-

① For selection of correct Power Code, refer to the Tables on pages 10-11.

Table 9.2 - Filter Static Pressure Drop ②

	BTS150	BTS175	BTS200	BTS250	BTS300	BTS350	BTS400
Filter Static ("W.C.)	0.1	0.2	0.1	0.2	0.2	0.2	0.2

② For blower units with enclosure and filter, add the following static pressures to the static pressure determined by the system designer for total external static pressure.

BLOWER PERFORMANCE DATA - MODEL BTS



Table 10.1 - Blower Model BTS 150-250 (40-55°F temp rise for 250 size unit) ① ② ③

Model Size	ATR	CFM	HP	External Static Pressure ("W.C.)																																					
				0.0			0.1			0.2			0.3			0.4			0.5			0.6			0.7																
				RPM	Drive	Turns	RPM	Drive	Turns	RPM	Drive	Turns	RPM	Drive	Turns	RPM	Drive	Turns	RPM	Drive	Turns	RPM	Drive	Turns	RPM	Drive	Turns	HP													
150	40	2778	1	573	175	4.5	615	175	4.0	658	175	3.0	699	175	2.5	738	175	1.5	775	175	1.0	810	175	0.5	-	-	-	1													
	45	2469	1/2	510	229	4.0	558	229	3.0	606	-	-	-	-	-	650	175	3.0	692	175	2.5	731	175	2.0	769	175	1.0	806	175	0.5	1/2										
	50	2222	1/3	460	232	4.0	513	-	-	565	-	-	612	-	-	656	-	-	699	-	-	739	-	-	779	-	-	-	-	-	1/3										
			1/2		229	5.0		229	4.0		229	3.0		229	2.0		229	1.5		229	1.0		229	0.5		229	0.5	229	0.5	229	0.5	229	0.5	1/2							
			1		-	-		-	-		175	4.5		175	4.0		175	3.0		175	2.5		175	2.0		175	1.5	175	1.0	175	1.0	175	1.0	175	1.0	1					
		55	2020	1/4	418	230	2.5	477	-	-	532	-	-	582	-	-	629	-	-	674	-	-	717	-	-	759	-	-	-	-	-	1/4									
				1/3		232	5.0		232	3.5		232	2.0		232	1.5		232	1.0		232	0.5		232	0.5		232	0.5	232	0.5	232	0.5	1/3								
				1/2		230	2.5		230	0.5		229	3.5		229	2.5		229	1.5		229	1.0		229	0.5		229	0.5	229	0.5	229	0.5	229	0.5	1/2						
	60	1852	1	384	-	-	448	-	-	506	-	-	559	-	-	609	-	-	656	-	-	701	-	-	741	-	-	-	-	-	1/3										
			1/2		230	3.5		230	1.5		230	0.0		229	4.0		229	3.0		229	2.0		229	1.0		229	0.5	229	0.5	229	0.5	229	0.5	229	0.5	1/2					
			1		-	-		-	-		-	-		-	-		-	-		-	-		-	-		-	-	-	-	-	-	-	-	-	-	-	-	-	1		
		65	1709	1/4	354	230	4.0	423	230	2.0	485	230	0.5	540	232	2.0	592	232	1.0	642	229	1.5	690	229	0.5	735	229	0.5	229	0.5	229	0.5	1/4								
				1/3		230	4.0		232	4.5		232	3.0		232	2.0		232	1.0		232	0.5		232	0.5		232	0.5	232	0.5	232	0.5	232	0.5	232	0.5	1/3				
				1/2		-	-		-	-		-	-		-	-		-	-		-	-		-	-		-	-	-	-	-	-	-	-	-	-	-	-	-	-	1/2
	70	1587	1/4	329	230	5.0	403	230	3.0	467	230	1.0	525	232	2.5	580	232	1.0	635	229	1.5	680	229	0.5	722	229	0.5	229	0.0	229	0.0	1/2									
			1/3		230	5.0		232	5.0		232	3.5		232	2.5		232	1.5		232	1.0		232	0.5		232	0.5	232	0.5	232	0.5	232	0.5	232	0.5	232	0.5	1/3			
			1/2		-	-		-	-		229	5.0		229	4.0		229	3.0		229	2.0		229	1.5		229	1.0	229	0.5	229	0.5	229	0.5	229	0.5	229	0.5	229	0.5	1/2	
		40	3241	1	625	175	3.5	655	175	3.0	690	175	2.5	727	237	5.0	764	237	4.5	799	237	3.5	834	237	2.5	866	237	2.0	237	2.0	237	2.0	1-1/2								
				1/2		175	5.0		175	4.5		175	3.5		175	3.0		175	2.0		175	1.5		175	1.0		175	0.5	175	0.5	175	0.5	175	0.5	1						
				1		-	-		-	-		-	-		-	-		-	-		-	-		-	-		-	-	-	-	-	-	-	-	-	-	-	-	-	-	1
	175	45	2881	1-1/2	555	-	-	589	-	-	630	-	-	672	-	-	712	-	-	750	-	-	786	-	-	821	-	-	-	-	1										
		50	2593	1	500	229	4.5	538	229	3.5	584	175	4.5	630	175	3.5	673	175	3.0	713	175	2.0	751	175	1.5	788	175	0.5	1	1											
		55	2357	1/2	454	238	2.5	497	-	-	548	-	-	597	-	-	642	-	-	684	-	-	724	-	-	763	-	-	-	-	-	1/3									
				1/3		238	2.5		238	2.5		238	2.0		238	1.5		238	1.0		238	0.5		238	0.5		238	0.5	238	0.5	238	0.5	238	0.5	238	0.5	238	0.5	1/2		
1				229		5.0	229		4.5	229		3.5	229		2.5	229		1.5	229		1.0	229		0.5	229		0.5	229	0.5	229	0.5	229	0.5	229	0.5	229	0.5	229	0.5	1/2	
60			2160	1/2	416	-	-	464	-	-	520	-	-	571	229	4.0	618	229	2.0	662	229	1.0	705	229	0.5	745	229	0.5	229	0.5	229	0.5	1/2								
				1		-	-		-	-		-	-		-	-		-	-		-	-		-	-		-	-	-	-	-	-	-	-	-	-	-	-	-	1	
				1-1/2		-	-		-	-		-	-		-	-		-	-		-	-		-	-		-	-	-	-	-	-	-	-	-	-	-	-	-	-	-
65		1994	1/3	384	238	4.5	438	238	3.0	497	238	1.5	550	238	0.0	599	238	0.0	645	229	1.5	690	229	0.5	733	229	0.5	229	0.5	229	0.5	1/3									
			1/2		238	4.5		238	3.0		238	1.5		238	0.0		238	0.0		238	0.0		238	0.0		238	0.0	238	0.0	238	0.0	238	0.0	238	0.0	238	0.0	238	0.0	1/2	
			1		-	-		-	-		-	-		-	-		-	-		-	-		-	-		-	-	-	-	-	-	-	-	-	-	-	-	-	-	-	1
		70	1852	1/3	356	238	5.0	415	238	3.5	477	238	2.0	533	238	0.5	584	238	0.5	632	229	1.5	678	229	0.5	728	229	0.5	229	0.5	229	0.5	1/3								
				1/2		238	5.0		238	3.5		238	2.0		238	0.5		238	0.5		238	0.5		238	0.5		238	0.5	238	0.5	238	0.5	238	0.5	238	0.5	238	0.5	238	0.5	1/2
				1		-	-		-	-		-	-		-	-		-	-		-	-		-	-		-	-	-	-	-	-	-	-	-	-	-	-	-	-	-
200		40	3704	1-1/2	715	235	3.5	741	235	2.5	770	235	2.0	-	-	-	-	-	-	-	-	-	-	-	-	-	-	-	-	-	1-1/2										
		45	3292	1	635	175	3.5	665	175	3.0	698	175	2.5	735	175	2.0	772	175	1.5	807	175	1.0	841	175	0.5	873	175	0.5	1	1											
		50	2963	1-1/2	571	229	1.5	604	229	1.0	643	229	1.0	684	235	4.0	723	235	3.0	761	235	2.0	797	235	1.0	831	235	0.0	235	0.0	235	0.0	1-1/2								
				1		175	4.5		175	4.0		175	3.5		175	2.5		175	2.0		175	1.5		175	1.0		175	0.5	175	0.5	175	0.5	175	0.5	175	0.5	1				
				1-1/2		229	3.0		229	2.5		229	1.5		229	0.5		229	0.5		229	0.0		229	0.0		229	0.0	229	0.0	229	0.0	229	0.0	229	0.0	229	0.0	229	0.0	1
			55	2694	1/2	519	233	2.5	556	-	-	600	-	-	644	-	-	686	-	-	725	-	-	763	-	-	799	-	-	-	-	-	1/2								
					1		233	2.5		233	2.5		233	1.5		233	1.0		233	0.5		233	0.5		233	0.5		233	0.5	233	0.5	233	0.5	233	0.5	233	0.5	233	0.5	1	
					1-1/2		229	4.0		229	3.0		229	2.5		229	1.5		229	1.0		229	0.5		229	0.5		229	0.5	229	0.5	229	0.5	229	0.5	229	0.5	229	0.5	229	0.5
		60	2469	1/2	475	233	2.5	516	233	2.5	565	233	1.5	612	233	1.0	656	233	0.5	697	233	0.5	736	233	0.5	774	233	0.5	233	0.5	233	0.5	1/2								
				1		229	5.0		229	4.0		229	3.0		229	2.0		229	1.0		229	0.5		229	0.5		229	0.5	229	0.5	229	0.5	229	0.5	229	0.5	229	0.5	1		
	1-1/2			-		-	-		-	-		-	-		-	-		-	-		-	-		-	-		-	-	-	-	-	-	-	-	-	-	-	-	-	1-1/2	
	65		2279	1/2	439	233	4.5	484	233	3.5	537	233	2.0	586	233	1.0	632	233	0.0	675	233	0.0	716	233	0.0	756	233	0.0	233	0.0	233	0.0	1/2								
				1		233	4.5		233																																

BLOWER PERFORMANCE DATA - MODEL BTS



Table 11.1 - Blower Model BTS 250-400 (60-70°F temp rise for 250 size unit) ① ② ③

Model Size	ATR	CFM	HP	RPM	External Static Pressure ("W.C.)																								HP
					0.0		0.1		0.2		0.3		0.4		0.5		0.6		0.7										
					Drive	Turns	Drive	Turns	Drive	Turns	Drive	Turns	Drive	Turns	Drive	Turns	Drive	Turns	Drive	Turns	Drive	Turns							
250	60	3086	1/2	360	204	4.0	204	3.0	204	1.5	241	4.0	241	3.0	241	2.0	241	1.5	23	4.0	23	3.0	241	0.0	241	0.0	1		
			1-1/2	-	-	-	-	-	-	-	-	-	-	-	-	-	-	-	-	-	-	-	-	180	2.5	2	1-1/2		
			2	-	-	-	-	-	-	-	-	-	-	-	-	-	-	-	-	-	-	-	-	-	-	-	180	4.5	2
	65	2849	1/2	332	204	4.5	204	3.5	204	2.0	241	4.5	241	3.5	241	2.5	241	1.5	23	4.5	23	3.5	241	1.0	241	0.0	1		
			1	-	-	-	-	-	-	-	-	-	-	-	-	-	-	-	-	-	-	-	-	180	5.0	2	1-1/2		
			1-1/2	-	-	-	-	-	-	-	-	-	-	-	-	-	-	-	-	-	-	-	-	180	4.0	2	2		
	70	2646	1	308	204	5.0	204	4.5	204	2.5	241	5.0	241	4.0	241	3.0	241	2.0	23	5.0	23	3.5	241	1.0	241	0.5	1		
			1-1/2	-	-	-	-	-	-	-	-	-	-	-	-	-	-	-	-	-	-	-	-	180	5.0	2	1-1/2		
			2	-	-	-	-	-	-	-	-	-	-	-	-	-	-	-	-	-	-	-	-	180	4.5	2	2		
	300	40	5556	3	650	112	3.0	112	2.5	112	2.0	177	3.0	177	2.0	177	1.0	112	1.5	112	1.5	112	0.5	112	0.0	112	0.0	3	
				2	-	-	-	-	-	-	-	-	-	-	-	-	-	-	-	-	-	-	-	-	-	-	-	-	2
				1	-	-	-	-	-	-	-	-	-	-	-	-	-	-	-	-	-	-	-	-	-	-	-	-	3
45		4938	3	578	177	3.5	177	3.0	177	2.0	112	5.0	112	4.5	112	3.5	112	2.0	177	0.5	177	0.0	177	0.0	177	0.0	177	0.0	3
			2	-	-	-	-	-	-	-	-	-	-	-	-	-	-	-	-	-	-	-	-	-	-	-	-	-	1-1/2
			1-1/2	-	-	-	-	-	-	-	-	-	-	-	-	-	-	-	-	-	-	-	-	-	-	-	-	-	3
50		4444	3	520	243	2.5	243	1.5	243	0.0	112	5.0	112	4.5	112	3.5	112	2.5	112	2.5	112	1.5	112	1.5	112	1.0	112	1.0	3
			2	-	-	-	-	-	-	-	-	-	-	-	-	-	-	-	-	-	-	-	-	-	-	-	-	-	1
			1	-	-	-	-	-	-	-	-	-	-	-	-	-	-	-	-	-	-	-	-	-	-	-	-	-	1
55		4040	1	473	241	3.5	241	3.0	241	2.0	241	1.5	241	1.0	241	0.5	241	0.0	23	3.5	23	2.5	23	1.5	23	0.5	23	0.0	1-1/2
			1-1/2	-	-	-	-	-	-	-	-	-	-	-	-	-	-	-	-	-	-	-	-	-	-	-	-	-	1
			3	-	-	-	-	-	-	-	-	-	-	-	-	-	-	-	-	-	-	-	-	-	-	-	-	-	3
60	3704	1	433	241	4.5	241	3.5	241	3.0	241	2.0	241	1.5	241	1.0	241	0.5	241	0.0	243	3.0	243	2.5	243	1.5	243	0.5	1-1/2	
		1-1/2	-	-	-	-	-	-	-	-	-	-	-	-	-	-	-	-	-	-	-	-	-	-	-	-	-	1	
		3	-	-	-	-	-	-	-	-	-	-	-	-	-	-	-	-	-	-	-	-	-	-	-	-	-	3	
65	3419	1	400	241	5.0	241	4.5	241	3.5	241	2.5	241	1.5	241	1.0	241	0.5	241	0.0	243	5.0	243	4.5	243	3.5	243	2.5	3	
		1-1/2	-	-	-	-	-	-	-	-	-	-	-	-	-	-	-	-	-	-	-	-	-	-	-	-	-	1	
		3	-	-	-	-	-	-	-	-	-	-	-	-	-	-	-	-	-	-	-	-	-	-	-	-	-	3	
70	3175	1	371	240	5.0	241	5.0	241	4.0	241	3.0	241	2.0	241	1.0	241	0.5	241	0.0	243	5.0	243	4.5	243	3.5	243	2.5	3	
		1-1/2	-	-	-	-	-	-	-	-	-	-	-	-	-	-	-	-	-	-	-	-	-	-	-	-	-	1-1/2	
		3	-	-	-	-	-	-	-	-	-	-	-	-	-	-	-	-	-	-	-	-	-	-	-	-	-	3	
350	40	6481	5	721	245	3.0	245	3.0	245	2.5	245	2.0	245	1.5	245	1.0	245	0.5	246	0.0	246	0.0	246	0.0	246	0.0	246	0.0	5
			3	-	-	-	-	-	-	-	-	-	-	-	-	-	-	-	-	-	-	-	-	-	-	-	-	-	3
			1	-	-	-	-	-	-	-	-	-	-	-	-	-	-	-	-	-	-	-	-	-	-	-	-	-	5
	45	5761	5	643	246	3.5	246	1.0	246	1.0	180	4.0	180	4.0	180	3.0	180	2.0	246	1.5	246	1.0	246	1.0	246	0.5	246	0.5	3
			3	-	-	-	-	-	-	-	-	-	-	-	-	-	-	-	-	-	-	-	-	-	-	-	-	-	2
			1	-	-	-	-	-	-	-	-	-	-	-	-	-	-	-	-	-	-	-	-	-	-	-	-	-	5
	50	5185	2	579	180	5.0	177	3.5	177	3.0	177	2.0	177	1.0	246	2.5	246	1.5	246	1.0	246	0.5	246	0.5	246	0.5	246	0.5	3
			3	-	-	-	-	-	-	-	-	-	-	-	-	-	-	-	-	-	-	-	-	-	-	-	-	-	5
			1	-	-	-	-	-	-	-	-	-	-	-	-	-	-	-	-	-	-	-	-	-	-	-	-	-	1-1/2
	55	4714	1-1/2	528	247	3.5	247	3.0	247	2.0	250	0.5	250	0.0	252	5.0	180	4.5	180	3.5	180	2.5	180	2.0	180	1.0	180	1.0	2
			2	-	-	-	-	-	-	-	-	-	-	-	-	-	-	-	-	-	-	-	-	-	-	-	-	-	2
			5	-	-	-	-	-	-	-	-	-	-	-	-	-	-	-	-	-	-	-	-	-	-	-	-	-	5
60	4321	1-1/2	484	247	5.0	247	4.0	247	3.0	250	2.5	250	1.0	252	5.0	252	4.5	252	3.5	252	2.5	252	2.5	252	2.5	252	2.5	1-1/2	
		2	-	-	-	-	-	-	-	-	-	-	-	-	-	-	-	-	-	-	-	-	-	-	-	-	-	2	
		5	-	-	-	-	-	-	-	-	-	-	-	-	-	-	-	-	-	-	-	-	-	-	-	-	-	5	
65	3989	1-1/2	448	250	4.0	250	2.5	250	1.0	250	0.0	252	5.0	252	4.5	252	4.5	252	3.5	252	3.5	252	2.5	252	2.5	252	2.5	1-1/2	
		2	-	-	-	-	-	-	-	-	-	-	-	-	-	-	-	-	-	-	-	-	-	-	-	-	-	2	
		5	-	-	-	-	-	-	-	-	-	-	-	-	-	-	-	-	-	-	-	-	-	-	-	-	-	5	
70	3704	1-1/2	416	250	5.0	250	4.0	250	2.5	250	1.0	252	5.0	252	4.5	252	4.0	252	3.0	252	2.5	252	2.0	252	1.5	252	1.0	1-1/2	
		2	-	-	-	-	-	-	-	-	-	-	-	-	-	-	-	-	-	-	-	-	-	-	-	-	-	2	
		5	-	-	-	-	-	-	-	-	-	-	-	-	-	-	-	-	-	-	-	-	-	-	-	-	-	5	
400	40	7407	5	823	245	0.5	245	0.0	245	0.0	246	1.5	246	1.0	246	0.5	246	0.0	246	0.0	246	0.0	246	0.0	246	0.0	246	0.0	5
			3	-	-	-	-	-	-	-	-	-	-	-	-	-	-	-	-	-	-	-	-	-	-	-	-	-	3
			1	-	-	-	-	-	-	-	-	-	-	-	-	-	-	-	-	-	-	-	-	-	-	-	-	-	5
	50	5926	5	660	246	3.0	246	2.5	246	1.5	246	1.0	246	0.5	246	0.0	246	0.0	246	0.0	246	0.0	246	0.0	246	0.0	246	0.0	3
			3	-	-	-	-	-	-	-	-	-	-	-	-	-	-	-	-	-	-	-	-	-	-	-	-	-	5
			1	-	-	-	-	-	-	-	-	-	-	-	-	-	-	-	-	-	-	-	-	-	-	-	-	-	2
	55	5387	3	601	246	4.5	246	4.0	246	3.5	246	3.0	246	2.5	246	2.0	246	1.5	246	1.0									



Table 12.1 - Electrical Selection Details - All Models

Model	Supply Voltage	Phase	Motor Voltage	Power Exhaust & Gas Control Circuit Voltage	Accessory Transformer Required ①	Factory Installed Transformer	Motor Starter Coil Voltage
HDS/HDC & PTS	115	1	115V/1ph	115V/1ph	none	115V to 24V	none
	208	1 or 3			208V to 115V		
	230				230V to 115V		
	460	3			460V to 115V		
	575				575V to 115V		
BTS	115	1	115V/1ph	115V/1ph	none	115 to 24V	none
	208	1	208V/1ph		208V to 115V		
	230		230V/1ph		230V to 115V		
	208	3	208V/3ph		208V to 115V		
	230		230V/3ph		230V to 115V		
	460	3	460V/3ph		460V to 115V		
	575		575V/3ph		575V to 115V		

① For accessory transformer sizing, refer to Table 6.2 for HDS, HDC, and PTS models and Table 7.5 for model BTS.

Table 12.2 - Gas Controls – All Models ②

Model Size	Control System Description	Gas Type	Control Code	Control Voltage
30-400	Single-Stage, Direct Spark Ignition Utilizes a single-stage combination gas control and an ignition control. Gas is automatically lit with the direct spark igniter on call for heat.	Natural	11	24V
		Propane	21	
75-400	Two-Stage, Direct Spark Ignition Utilizes a two-stage combination gas control (fires at 50% or 100% of full rated input) and an ignition control. Gas is automatically lit with the direct spark igniter on call for heat.	Natural	12	
		Propane	22	

② All ignition controls are 100% Shut-Off with Continuous Retry.

Table 13.1 - Field Installed Accessories

	Feature	Model			
		HD	HDB	PTS	BTS
Cabinet and Air Mover	Vertical Deflector Blades - Allows directional discharge air control in the left and right directions.	•	•	•	•
	Downward Air Deflector Hoods - Available in 30°, 60°, and 90° configurations these deflector hoods enable the unit to be mounted higher while still providing heat to the building occupants. Refer to page 14 for further details.	•	•	•	•
	Vibration Isolation Kit - Minimizes unit vibration transmission to the building structure.	•	•		
	Horizontal Concentric Vent Kit - Enables horizontal concentric venting. Kit consists of one concentric adaptor, one vent terminal, and one bird screen. (See Figure 13.1.)	•	•	•	•
	Vertical Concentric Vent Kit - Enables vertical concentric venting. Kit consists of one concentric adaptor, one combustion air inlet cap, and one vent terminal cap. (See Figure 13.2.)	•	•	•	•
	Pipe Hanger Adapter Kits - Allows the unit to be suspended by 3/4" pipe from the standard 3/8" holes found in the top of the unit.			•	•
	Discharge Transition for Polytube - Allows for the connection of polytube (not included) to the discharge of the unit.		•		•
	Blower Enclosure with or without Filter Rack - Totally encases the motor and blower assembly. Optional filters provide filtering of the air prior to entering the heater.		•		•
Controls	Belt Guard - Provides protection for building occupants as well as service people from the drive belt and sheaves.				•
	Natural Gas to Propane Gas Conversion Kit - Provides all required parts as well as instructions to convert a natural gas unit to propane gas.	•	•	•	•
	Single or Two-Stage Room Thermostats - See Table 13.2 for details.	•	•	•	•
	Room Thermostat Guard - Clear plastic for room thermostats. Guard is locking type and comes with two keys.	•	•	•	•
	Stepdown Transformers - Used to operate propeller units on 208/230/460/575V/3Ph supply voltage. Also may be required for control circuits for blower units. Refer to Table 12.1 for further selection details.	•	•	•	•
	Control Relays - This single pole single throw relay consists of a 24V coil with a maximum contact rating of 18 amps at 115V.	•	•	•	•
Gas Pressure Regulator - Fisher Type S-100, 3/4 inch pressure regulator for 1/2 to 50 psi inlet pressure capacity, 30 MBH to 400 MBH.	•	•	•	•	

Figure 13.1 - Horizontal Concentric Vent Kit

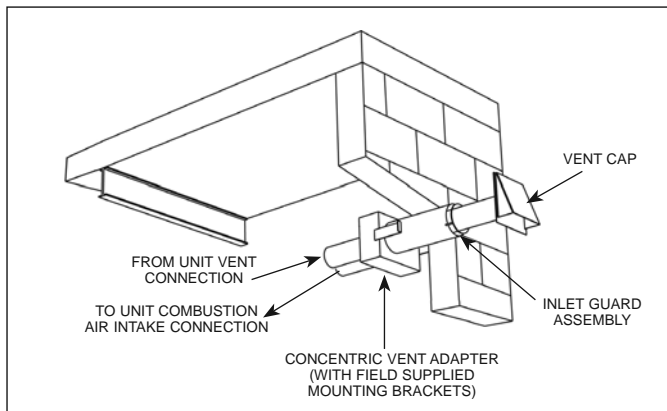

Figure 13.2 - Vertical Concentric Vent Kit

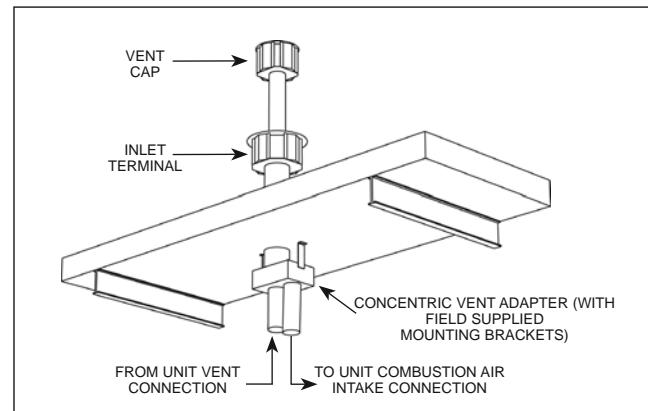

Table 13.2 - Field Installed Thermostats

	Type	Description
Single-Stage Thermostats	Room Thermostat	White Rodgers 1C20-101: 50° - 90°F, 1.0A @ 24VAC
		White Rodgers 1C26-101: 50° - 90°F, 1.0A @ 24VAC, Heat/Off & Fan On/Auto Switches
Two-Stage Thermostats	Room - Digital	Honeywell TH5220D1003: 40° - 90°F, 1.0A @ 24VAC, System Heat/Cool/Auto/Off, Fan On/Auto
	Duct	Johnson Controls A350 Electronic Temp Control with Sensor and S350 Stage Adder (Blower units only)
		Honeywell T678A1015: 0° - 100°F, 20' capillary tube (Blower units only)

PERFORMANCE DATA - HOODS FOR PROPELLER MODELS



Figure 14.1 - 30°, 60°, and 90° Downward Deflector Hoods

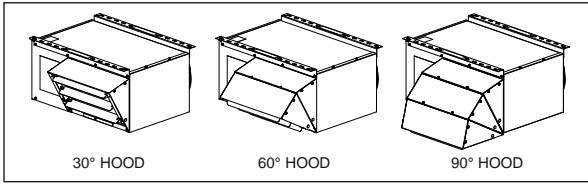

Figure 14.2 - 30° and 60° Throw/Floor Coverage

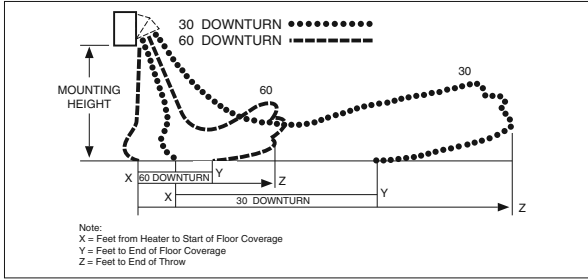

Figure 14.3 - 90° Hood Throw/Floor Coverage

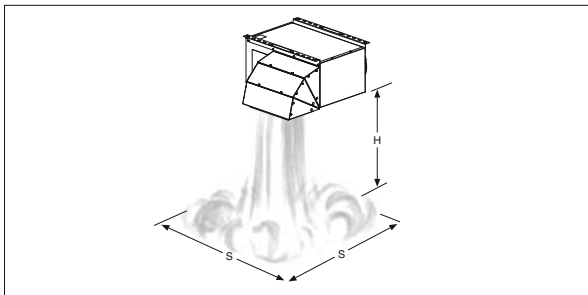

Table 14.1 - Deflector Hood General Performance Data - Model HDS

Model Size	Airflow (cfm)	Temp Rise (°F)	Mounting Height (ft)	Blade Angle (°)	30° Hood			60° Hood			90° Hood
					X (ft)	Y (ft)	Z (ft)	X (ft)	Y (ft)	Z (ft)	S (ft)
30	505	44	8	31	6	15	21	0	14	20	10
			9	15	4	12	18	0	11	15	10
45	720	46	8	52	11	25	34	0	25	35	17
			10	39	9	23	31	0	22	31	15
			12	22	7	19	27	0	17	24	14
60	990	45	8	49	10	23	31	0	23	32	15
			10	35	8	20	28	0	20	28	14
			12	10	5	15	22	0	13	18	13
75	1160	48	8	55	12	27	37	0	28	38	19
			10	44	10	25	34	0	25	35	17
			12	30	9	22	31	0	21	29	15
			14	13	6	18	26	0	15	22	14
100	1490	50	8	52	11	25	34	0	26	35	17
			10	40	9	23	32	0	23	31	15
			12	23	7	19	27	0	18	25	14
			13	10	5	15	22	0	13	18	13
125	1980	47	8	63	17	36	49	0	38	52	27
			10	56	15	35	48	0	36	50	24
			12	48	14	33	46	0	34	46	22
			14	38	13	31	43	0	31	42	21
			16	26	11	27	39	0	26	36	19
			18	18	9	25	35	0	15	21	18

Note: Refer to Figures 14.2 through 14.3.

Table 14.2 - Deflector Hood General Performance Data - Model PTS

Model Size	Airflow (cfm)	Temp Rise (°F)	Mounting Height (ft)	Blade Angle (°)	30° Hood			60° Hood			90° Hood
					X (ft)	Y (ft)	Z (ft)	X (ft)	Y (ft)	Z (ft)	S (ft)
150	2139	53	8	60	15	32	44	0	34	47	24
			10	52	13	31	42	0	32	44	21
			12	42	12	29	40	0	29	40	19
			14	30	10	26	36	0	25	34	18
			16	9	7	20	29	0	17	24	17
175	2726	48	8	60	14	32	43	0	33	46	23
			10	51	13	30	42	0	31	43	21
			12	41	12	28	39	0	28	39	19
			14	29	10	25	35	0	24	33	17
			16	8	6	17	26	0	15	21	16
200	2780	54	8	59	14	30	42	0	32	44	22
			10	49	12	29	40	0	30	41	19
			12	39	11	27	37	0	26	36	18
			14	24	9	23	33	0	21	30	16
			15	13	7	20	29	0	17	24	16
			17	12	8	22	32	0	19	27	18
250	3994	47	8	66	19	41	56	0	43	59	32
			10	60	18	40	54	0	42	57	29
			12	53	17	38	53	0	40	54	26
			14	46	15	36	50	0	37	51	24
			16	37	14	34	47	0	33	46	23
			18	26	12	31	43	0	28	40	21
			20	8	7	22	32	0	19	26	20
300	4543	50	8	69	22	45	62	0	48	66	37
			10	63	21	44	61	0	47	64	33
			12	57	19	43	59	0	45	62	30
			14	51	18	42	57	0	43	59	28
			16	44	17	40	55	0	40	55	26
			18	35	15	37	52	0	36	50	25
			20	25	13	33	47	0	31	43	24
			22	9	8	25	37	0	21	30	23
350	5278	50	8	68	20	43	58	0	45	62	34
			10	61	19	42	57	0	44	60	31
			12	55	18	40	55	0	42	58	28
			14	48	17	39	53	0	40	54	26
			16	40	15	37	51	0	36	50	24
			18	31	13	34	47	0	32	44	23
			20	17	10	29	41	0	25	35	22
			21	2	7	23	34	0	18	26	21
400	5995	51	8	70	24	49	66	0	52	71	41
			10	65	22	48	65	0	51	69	37
			12	59	21	47	64	0	49	67	34
			14	54	20	45	62	0	47	64	31
			16	47	19	44	60	0	44	61	29
			18	40	17	41	57	0	41	57	28
			20	32	15	38	54	0	37	51	26
			22	21	13	34	48	0	31	43	25
			23	13	11	31	44	0	26	37	24

Note: Refer to Figures 14.2 through 14.3.

PERFORMANCE DATA - HOODS FOR BLOWER MODELS



Table 15.1 - Deflector Hood General Performance Data - Model HDC

Model Size	Airflow (cfm)	Temp Rise (°F)	Mounting Height (ft)	Blade Angle (°)	30° Hood			60° Hood			90° Hood
					X (ft)	Y (ft)	Z (ft)	X (ft)	Y (ft)	Z (ft)	S (ft)
60	808	55	8	27	5	14	20	0	13	18	10
			9	8	4	11	16	0	8	12	9
75	1010	55	8	45	9	20	28	0	21	28	14
			10	27	7	17	24	0	16	23	12
			11	13	5	14	21	0	12	17	12
100	1347	55	8	44	9	20	28	0	21	28	14
			10	27	7	17	24	0	16	23	12
			11	12	5	14	20	0	12	17	12
125	1543	60	8	49	10	23	32	0	24	32	16
			10	35	8	21	29	0	20	28	14
			12	13	6	16	23	0	14	19	13

Note: Refer to Figures 14.2 through 14.3 on page 14.

Table 15.2 - Deflector Hood General Performance Data - Model BTS

Model Size	Airflow (cfm)	Temp Rise (°F)	Mounting Height (ft)	Blade Angle (°)	30° Hood			60° Hood			90° Hood
					X (ft)	Y (ft)	Z (ft)	X (ft)	Y (ft)	Z (ft)	S (ft)
150	2020	55	8	57	13	29	40	0	31	42	21
			10	48	12	28	38	0	28	39	19
			12	37	10	25	35	0	25	34	17
			14	21	8	21	30	0	19	27	16
			15	10	7	19	27	0	12	18	15
175	2357	55	8	51	11	24	33	0	25	34	17
			10	39	9	22	31	0	22	30	15
			12	22	7	19	26	0	17	23	14
			13	2	5	14	21	0	10	14	13
200	2694	55	8	57	13	29	39	0	30	41	20
			10	47	12	27	37	0	28	38	18
			12	35	10	25	34	0	24	33	17
			14	18	7	20	29	0	18	25	15
			15	2	5	16	24	0	11	16	15
250	3367	55	8	59	14	31	42	0	32	44	22
			10	50	13	29	40	0	30	41	20
			12	39	11	27	37	0	27	37	18
			14	25	9	23	33	0	22	30	17
			15	15	7	20	29	0	18	25	16
300	4040	55	8	64	17	37	51	0	40	54	29
			10	57	16	36	50	0	38	52	26
			12	50	15	35	48	0	36	49	23
			14	41	13	33	45	0	33	45	22
			16	30	12	30	41	0	28	39	20
			18	14	9	24	35	0	21	29	19
350	4714	55	8	63	16	36	49	0	37	51	27
			10	55	15	34	47	0	36	49	24
			12	47	14	33	45	0	33	46	22
			14	37	12	30	42	0	30	41	20
			16	25	10	27	38	0	25	34	19
			18	2	6	20	29	0	13	19	18
400	5387	55	8	67	19	41	56	0	44	60	32
			10	60	18	40	55	0	42	58	29
			12	53	17	39	53	0	40	55	26
			14	46	15	37	51	0	37	51	25
			16	37	14	34	48	0	34	47	23
			18	26	12	31	43	0	29	40	22
			20	8	8	23	34	0	20	28	21

Note: Refer to Figures 14.2 through 14.3 on page 14.

Selection Procedure

In order to properly select a unit heater it is necessary to have the following basic information.

1. Heating output capacity

Model size output is to be matched against the heat loss to be replaced.

2. External static pressure (blower units only)

The external static pressure (E.S.P.) is determined using the ASHRAE Guide for duct losses or provided by the design engineer.

3. Accessory internal static pressure (transitions, filters, etc.) (blower units only)

The critical accessories are those that add internal static pressure (I.S.P.) to the unit. Once these items are determined, the total pressure drop can be determined (if applicable).

4. Heat exchanger material

The heat exchanger type is determined by the application. The standard heat exchanger material is aluminized steel. A 409 stainless steel heat exchanger is recommended when the combined entering/return air to the unit is below 40°F or in high humidity applications.

5. Type of fuel

Either natural or propane gas determined by the design engineer.

6. Gas controls

Either single stage or two stage, as determined by the design engineer.

7. Main power supply voltage to unit

Selection Example (Propeller Unit)

Selection Example Conditions (Propeller Unit)

Select a unit heater to meet the following conditions:

1. Heating output capacity = 156,000 Btu/Hr per design engineer
2. External Static Pressure = 0.0
3. Internal Static Pressure = 0.0. No static producing accessories are required
4. Heat exchanger and burner = 409 Stainless Steel
5. Gas Type = Natural
6. Gas Controls = Single Stage
7. Supply Voltage: 460V/60Hz/3Ph

With the information listed above, the basic model, using the information in this catalog and the Model Nomenclature shown on page 23, can be selected as shown:

1. Determine the Model and Input Rating (MBH):

Using the Heating output capacity, the Furnace Input Rating is determined from Table 6.1. The closest model to 156,000 Btu/Hr output has an Btu/Hr Input rating of 200,000 Btu/Hr so the Furnace Input Rating = 200. The corresponding model for a 200 size, propeller, separated combustion unit heater is PTS. The model and size are a PTS200.

2. Determination of Heat Exchanger Material:

From item #4 in the example, the Heat Exchanger required is 409 Stainless Steel. Thus, the Heat Exchanger Material = S from the Model Nomenclature on page 23.

3. Determine the Ignition Type:

The Ignition Type = S from the Model Nomenclature on page 23.

4. Determine Power Code Required:

Referring to Table 6.2, it can be seen that the supply voltage from the example conditions is not available (460V). A transformer kit selected later in this example must be used. In this instance, from Table 6.2 select the 115V/60Hz/1Ph power code (PC) = 01 unit.

5. Determine the control type:

From items #5 and #6 in the example conditions, the gas type is Natural Gas and controls are Single Stage. From Table 12.2, we are directed to use Control Code (CC) of 11.

6. Determine the fan guard type:

No specific type of fan guard was specified, so select Fan Guard = S from the Model Nomenclature on page 23.

At this point we have a full model number of:

PTS200SS0111SBAN

7. Determination of transformer:

To operate a 115V/60Hz/1Ph unit on 460V/60Hz/3Ph supply power a unit step down transformer must be selected. By referring to Table 12.1 we see that a 460V to 115V step down transformer is required. As noted in the footnote for Table 12.1, the size can be determined to be 0.75kVA from Table 6.2.

Selection Example (Blower Unit)

Selection Example Conditions (Blower Unit)

In the following example, select a unit heater to meet the following conditions:

1. Heating output capacity = 156,000 Btu/Hr per design engineer
2. External Static Pressure = 0.2.
3. Internal Static Pressure = 0.0. No static producing accessories are required at this point, but filters may be added later.
4. Heat exchanger and burner = Aluminized Steel
5. Gas Type = Propane
6. Gas Controls = Two Stage
7. Supply Voltage: 230V/60Hz/3Ph
8. CFM = 2,400

With the information listed above, the basic model, using the information in this catalog and the Model Nomenclature shown on page 23, can be selected as shown:

1. Determine the Model and Input Rating (MBH):

Using the Heating output capacity, the Furnace Input Rating is determined from Table 7.1. The closest model to 156,000 Btu/Hr output has an Btu/Hr Input rating of 200,000 Btu/Hr so the Furnace Input Rating = 200. The corresponding model for a 200 size, blower, separated combustion unit heater is BTS. The model and size are a BTS200.

2. Determination of Heat Exchanger Material:

From item #4 in the example, the Heat Exchanger required is aluminized steel. Thus, the Heat Exchanger Material = A from the Model Nomenclature on page 23.

3. Determine the Ignition Type:

The Ignition Type = S from the Model Nomenclature on page 23.

4. Determine Power Code Required:

From page 10 we see that a unit requiring a static of 0.2 and a cfm of 2400 requires a 1/2 horsepower motor with a -233 drive that is turned open 1.5 turns. Referring to Table 9.1 it can be determined that for a BTS200 with a 1/2 HP motor and a -233 drive operating on 230V/60Hz/3Ph that it will have a power code = 08. However, note that if filters are added later, that drive/motor combination will not be sufficient. Two alternate drive selections could have been made with a 1hp motor with either a -253 or -229 drive. The power code would be 30 or 19 respectively. Note that the 229 drive would likely be the best choice, as the turns open is near the center of the range.

5. Determine the control type:

From items #5 and #6 in the example, the gas type is Propane Gas and controls are Two Stage. From Table 12.2, we are directed to use Control Code (CC) = 22.

At this point we have a full model number of:
BTS200AS1922NBAN

6. Determination of Transformer:

To operate the BTS200AS1922NBAN on 230V/60Hz/3ph supply voltage, we need to review Table 12.1 to determine if any field installed transformers are required. The table indicates that we need a 230V to 115V step down transformer for the power exhaust and gas control circuit voltage. As indicated in the footnote for that table, Table 7.5 directs us to the correct size for this model, which is 0.5kVA. Transformers for blower models are typically smaller than those used for propeller models, as the transformer is not needed for the blower motor.

Figure 18.1 - Dimensional Drawings - Models HDS/HDC

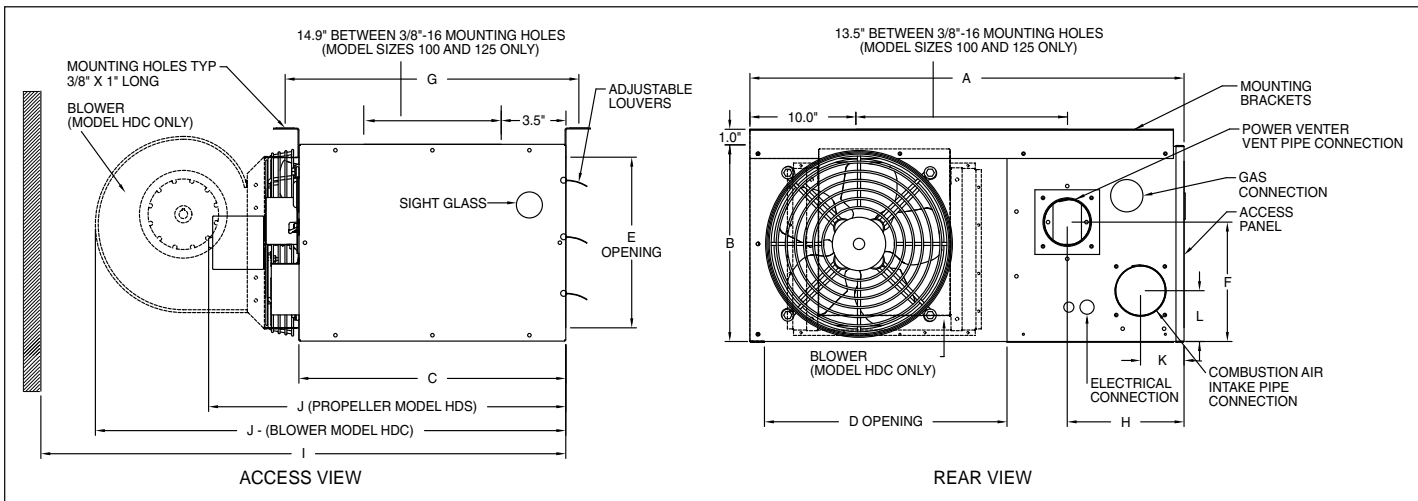

Table 18.1 - Dimensions (inches) ①

Dimension	Propeller Model Size - HDS					Blower Model Size - HDC		
	30	45	60	75	100/125	60	75	100/125
A	26.8	26.8	26.8	26.8	35.5	26.8	26.8	35.5
B	12.2	12.2	18	18	20.5	18	18	20.5
C	16.5	16.5	16.5	16.5	22	16.5	16.5	22
D	14.9	14.9	14.9	14.9	22.5	14.9	14.9	22.5
E	10.1	10.1	15.9	15.9	18.4	15.9	15.9	18.4
F	7.25	7.25	10.75	10.75	14	10.75	10.75	14
G	18.5	18.5	18.5	18.5	-	18.5	18.5	-
H	7.6	7.6	7.835	7.835	8.4	7.835	7.835	8.4
I	34.5	34.5	34.5	34.5	43	35.5	35.5	44.5
J	22	22	25	25	31	32.5	32.5	41.5
K	2.74	2.74	3.15	3.15	3.87	3.15	3.15	3.87
L	3.19	3.19	5.55	5.55	10.73	5.55	5.55	10.73
Gas Connector	1/2"	1/2"	1/2"	1/2"	1/2"	1/2"	1/2"	1/2"
Vent and Combustion Air Connector Size	3	3	4	4	4	4	4	4
Fan or Blower Diameter	10	10	14	14	18	9 - 7	9 - 7	10 - 10
Approx. Weight (lbs.)	55	60	80	85	125	92	97	125

① Do not use propeller units with duct work.

Figure 18.2 - Mounting Bracket Slot Locations

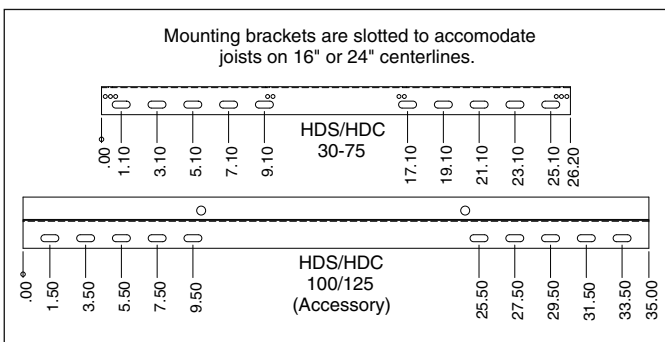

Table 18.2 - Clearances

Unit Side	Clearance To Combustible Materials	Recommended Service Clearance
Top and Bottom	1"	18"
Access Side	1"	18"
Non-Access Side	1"	18"
Rear	18"	18"
Vent Connector	4"	18"

DIMENSIONAL DATA - MODEL PTS



Figure 19.1 - Dimensional Drawings - Model PTS

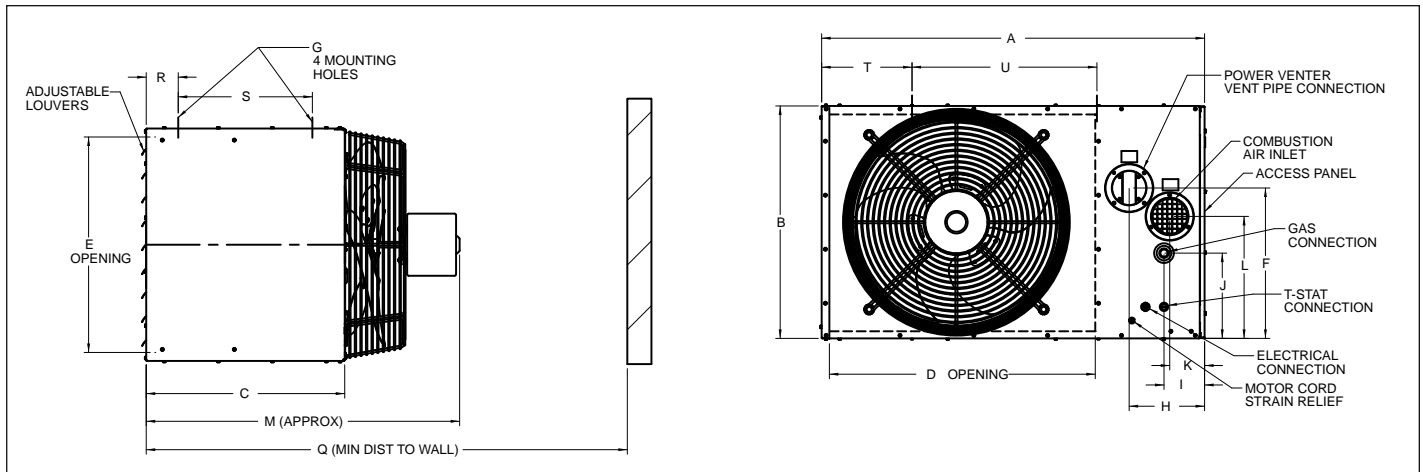

Table 19.1 - Dimensions (inches) - PTS ①

Models	PTS150	PTS175	PTS200	PTS250	PTS300	PTS350	PTS400
A	35.53	42.53	42.53	42.53	42.53	42.53	42.53
B	23.06	25.81	25.81	31.31	31.31	39.56	39.56
C	22.05	22.05	22.05	22.05	22.05	22.05	22.05
D	22.52	29.52	29.52	29.52	29.52	29.52	29.52
E	21.18	23.93	23.93	29.43	29.43	37.68	37.68
F	15.33	16.70	16.70	19.45	19.45	23.58	23.58
G (Mounting Hole) ②	3/8-16	3/8-16	3/8-16	3/8-16	3/8-16	3/8-16	3/8-16
H	8.37	8.37	8.37	8.37	8.37	8.37	8.37
I	4.50	4.50	4.50	4.50	4.50	4.50	4.50
J	8.09	9.47	9.47	6.72	6.72	10.84	10.84
K	3.87	3.87	3.87	5.20	5.20	5.20	5.20
L	12.17	13.55	13.55	12.66	12.66	16.78	16.78
M	31.79	32.83	34.43	33.83	33.83	34.83	34.83
Q ③	43.79	44.83	46.43	45.83	45.83	46.83	46.83
R	3.56	3.56	3.56	3.56	3.56	3.56	3.56
S	14.90	14.90	14.90	14.90	14.90	14.90	14.90
T	10.00	10.00	10.00	10.00	10.00	10.00	10.00
U	13.54	20.53	20.53	20.53	20.53	20.53	20.53
Gas Connection	1/2	1/2	1/2	3/4	3/4	3/4	3/4
Vent and Combustion Air Connector Size	4"	4"	4"	6"	6"	6"	6"
Fan Diameter	20.00	22.00	22.00	22.00	22.00	24.00	24.00
Approx. Shipping Weight (lbs.)	165	210	220	265	270	310	320

① Do not use propeller units with duct work.
 ② Listed is the hole diameter and threads per inch to accept threaded rod.
 ③ Dimension equals overall plus 12".

Table 19.2 - Clearances to Combustible Materials

Unit Side	Clearance To Combustible Materials	Recommended Service Clearance
Top and Bottom	6"	6"
Access Side	6"	18"
Non-Access Side	6"	6"
Rear	18"	18"
Vent Connector	6"	6"

DIMENSIONAL DATA - MODEL BTS



Figure 20.1 - Dimensional Drawings - Model BTS

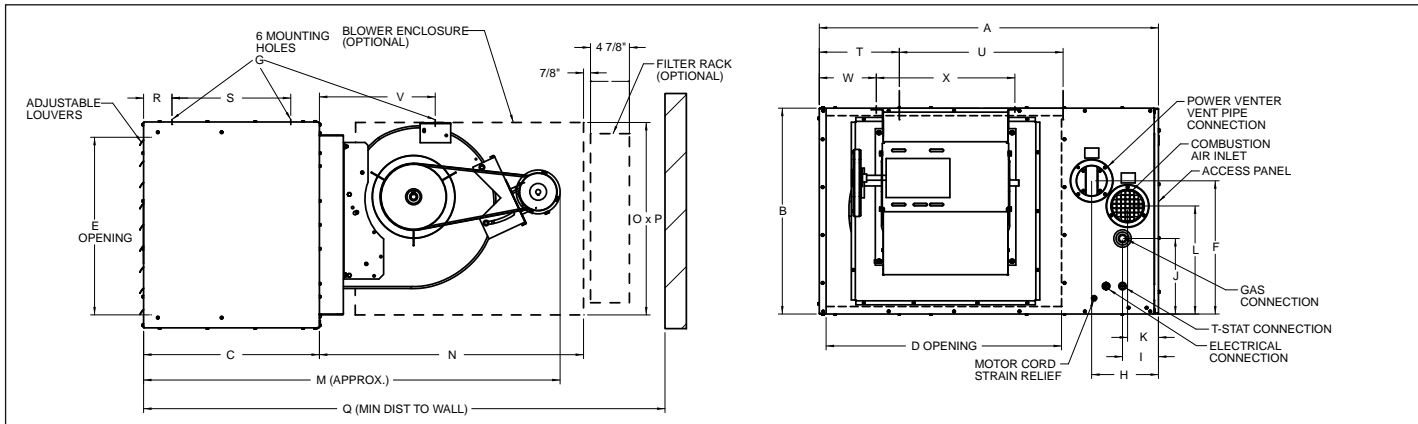

Table 20.1 - Dimensions (inches) — BTS

Models	BTS150	BTS175	BTS200	BTS250	BTS300	BTS350	BTS400
A	35.53	42.53	42.53	42.53	42.53	42.53	42.53
B	23.06	25.81	25.81	31.31	31.31	39.56	39.56
C	22.05	22.05	22.05	22.05	22.05	22.05	22.05
D	22.52	29.52	29.52	29.52	29.52	29.52	29.52
E	21.18	23.93	23.93	29.43	29.43	37.68	37.68
F	15.33	16.70	16.70	19.45	19.45	23.58	23.58
G (Mounting Hole) ①	3/8-16	3/8-16	3/8-16	3/8-16	3/8-16	3/8-16	3/8-16
H	8.37	8.37	8.37	8.37	8.37	8.37	8.37
I	4.50	4.50	4.50	4.50	4.50	4.50	4.50
J	8.09	9.47	9.47	6.72	6.72	10.84	10.84
K	3.87	3.87	3.87	5.20	5.20	5.20	5.20
L	12.17	13.55	13.55	12.66	12.66	16.78	16.78
M ②	52.25	52.19	52.19	58.88	58.88	58.88	58.88
N	33.18	33.90	33.90	39.88	39.88	39.88	39.88
O	23.90	24.13	24.13	27.04	27.04	28.57	28.57
P	24.77	24.52	24.52	27.19	27.19	28.28	28.28
Q (w/Blower Encl & Filter Rack)	73.04	73.70	73.70	79.68	79.68	79.68	79.68
Q (w/o Blower Encl & Filter Rack)	64.25	64.19	64.19	70.88	70.88	70.88	70.88
R	3.56	3.56	3.56	3.56	3.56	3.56	3.56
S	14.90	14.90	14.90	14.90	14.90	14.90	14.90
T	10.00	10.00	10.00	10.00	10.00	10.00	10.00
U	13.54	20.53	20.53	20.53	20.53	20.53	20.53
V	14.52	14.52	14.52	18.04	18.04	18.00	18.00
W	3.27	7.15	7.15	4.77	4.77	5.24	5.24
X	17.38	17.38	17.38	20.38	20.38	20.38	20.38
Gas Connection	1/2	1/2	1/2	3/4	3/4	3/4	3/4
Vent and Combustion Air Connector Size	4"	4"	4"	6"	6"	6"	6"
Blower	12-12	12-12	12-12	15-15	15-15	15-15	15-15
Approx. Shipping Weight (lbs.)	220	275	280	340	345	395	405

① Listed is the hole diameter and threads per inch to accept threaded rod.

② This is an approximate dimension for standard motors, allow 3" for sheave and optional motors.

Table 20.2 - Clearances to Combustible Materials

Unit Side	Clearance To Combustible Materials	Recommended Service Clearance
Top and Bottom	6"	6"
Access Side	6"	18"
Non-Access Side	6"	6"
Rear	18"	18"
Vent Connector	6"	6"

General

A. Standards

All unit(s) shall include:

- A.1. ETL design certification for use in both the US and Canada to the ANSI Z83.8 - latest revision, standard for "Gas Unit Heater and Gas-Fired Duct Furnaces" for safe operation, construction, and performance.

B. Mechanical Configuration

- B.2. Furnace(s) section with 82% minimum efficiency provided by an indirect-fired tubular heat exchanger with individually fired tubes.

C. Venting Arrangement

- C.3. The unit shall be separated combustion. The venting shall be a power exhausted arrangement with a separate combustion air intake pipe connection to allow for fresh combustion air from outside the conditioned space. The unit shall be tested to insure proper ignition when the unit is subjected to 40 mile per hour wind velocities. The unit shall also include a factory mounted differential pressure switch designed to prevent main burner ignition until positive venting has been proven.

D. Unit Casing

- D.1 The unit heater(s) casing shall be constructed of not less than 20 gauge aluminized steel with minimization of exposed fasteners. (PTS/BTS models)
- D.1.a. The unit heater(s) casing shall be constructed of not less than 22 gauge aluminized steel with minimization of exposed fasteners. (HDS/HDC models)
- D.2. All exterior casing parts shall be cleaned of all oils and a phosphate coating applied prior to painting. All exterior casing parts shall be painted with an electrostatically applied baked-on gray-green polyester powder paint (7-mil thickness) for corrosion resistance.
- D.3. The unit shall be furnished with horizontal air deflectors. The deflectors are adjustable to provide for horizontal directional airflow control (up or down).

E. Furnace Section

- E.1.c. The heat exchanger(s) shall be made of 18 gauge aluminized steel tubes and headers (opt 409 stainless steel). The thermal efficiency of the unit(s) shall be a minimum of 82% efficient for all air flow ranges. Each heat exchanger tube shall be individually and directly flame-fired. The heat exchanger tube shall be crimped to allow for thermal expansion and contraction. The flue collector box shall be made of 20 gauge aluminized steel (opt 409 stainless).
- E.2. The heat exchanger(s) seams and duct connections shall be certified to withstand 0.9" W.C. external static pressure without burner flame disturbance.
- E.3.a. The burner(s) shall be in-shot type, directly firing each heat exchanger tube individually and is (are) designed for good lighting characteristics without noise of extinction for both natural and propane gas.
- E.5. The ignition controller(s) shall be 100% shut-off with continuous retry.
- E.6. The gas pressure shall be between 6-7" W.C for natural gas. (opt) The gas pressure shall be 11-14" W.C. for propane gas.

- E.7.a. The solid state ignition system shall directly light the gas by means of a direct spark igniter each time the system is energized.
- E.8. The unit gas controls shall be provided with the following:
 - E.8.d. (opt) Single-stage gas controls with a single-stage combination gas control, an ignition control, and a single-stage low voltage thermostat. The unit fires at 100% full fire based on a call for heat from a room thermostat.
 - E.8.e. (opt) Two-stage gas controls with a two-stage combination gas control, an ignition control, and a two-stage low voltage thermostat. The unit fires at 50% fire on low stage or 100% fire on high stage of the unit based on the call for heat from either a room or duct thermostat.
- E.9. An automatic reset high limit switch mounted in the air stream to shut off the gas supply in the event of overheating.
- E.10. A time delay relay that delays the start of the air mover to allow the heat exchanger a warm-up period after a call for heat. The time delay relay shall also continue the air mover operation after the thermostat has been satisfied to remove any residual heat in the heat exchanger.
- E.11. The unit shall be orificed for up to 2000' elevation above sea level. (opt) The unit shall be orificed for _____ elevation above sea level.

F. Electrical

- F.1. All electrical components shall carry UL, ETL, or CSA listing.
- F.2. A low voltage terminal board shall be provided for direct wiring connection to an external thermostat.
- F.3. A single 115V to 24V step down transformer shall be provided for all unit controls.

G. Air Mover

- G.1. The motor horsepower shall be _____.
- G.2. The motor wiring shall be in flexible metal BX conduit.
- G.3. (opt) The motor shall be controlled by a time delay relay.
- G.4. Propeller models shall meet the following requirements.
 - G.4.a. The motor type shall be single-speed, totally enclosed (TE) (open drip proof (ODP) on HDS units 75MBH and smaller).
 - G.4.b. The motor shall be rated for:
 - (a) 115V/60Hz/1Ph
- G.5. Blower models shall meet the following requirements.
 - G.5.a. The motor type shall be single-speed, totally enclosed (TE) (open drip proof (ODP) on all HDC models).
 - G.5.b. The motor shall be rated for:
 - (a) 115V/60Hz/1Ph
 - (b) 208V/60Hz/1Ph (BTS model)
 - (c) 230V/60Hz/1Ph (BTS model)
 - (d) 208V/60Hz/3Ph (BTS model)
 - (e) 230V/60Hz/3Ph (BTS model)
 - (f) 460V/60Hz/3Ph (BTS model)
 - (g) 575V/60Hz/3Ph (BTS model)

- G.5.c. The motor shall be provided with an adjustable motor sheave to allow for minor adjustment of the blower rpm at the job site. (BTS model)
- G.5.d. The blower shall be a double width, double inlet (DWDI), forward curved, belt driven, assembly with spider ball bearings. (BTS model)
- G.5.e. The motor shall be provided with three speed taps to allow for adjustment of the blower rpm at the job site. (HDC model)
- G.5.f. The blower shall be a double width, double inlet (DWDI), forward curved, direct motor drive assembly with spider ball bearings. (HDC model)

H. Mounting

- H.1. The unit shall be equipped with tapped holes to accept 3/8-16 threaded rod for suspension. (HDS/HDC size 100/125 and PTS/BTS models).
- H.1.a. The unit shall be equipped with mounting brackets to allow for threaded rod suspension or to be bolted directly to the ceiling support structure allowing 1" of top clearance. (HDS/HDC models - opt on sizes 100/125)
- H.3. Propeller unit (Sizes 30-400) and blower units (Sizes 60-125) to have 4 suspension points.
- H.4. Blower unit (Sizes 150-400) to have 6 suspension points.

J. Accessories

The following field installed accessory control devices shall be provided with the unit:

- J.1. A 5-50 psi gas pressure regulator to reduce the inlet gas pressure for the operating controls.
- J.2. A clear plastic thermostat guard with two keys for room thermostats.
- J.4. Pipe Hanger Adapter Kit to facilitate threaded pipe suspension. (HDS/HDC size 100/125 and PTS/BTS models)
- J.7. Vertical Deflector Kit to enable side distribution of airflow.
- J.8. A blower enclosure fully encloses blower to enable the attachment of filter racks and/or duct.
- J.9. A combination filter rack/duct connector containing a 1" thick, cleanable filter.
- J.11. A belt guard enclosing the belts and sheaves (pulleys) on a blower type unit heater. (BTS model)
- J.12. Propane conversion kit for converting natural gas units to propane gas.
- J.17. Discharge Transition from unit to polytube. (HDC/BTS models)
- J.18. 30° non-velocity generating downward air deflector hood constructed of 20 ga. cold rolled steel with baked-on gray-green polyester powder paint.
- J.19. 60° non-velocity generating downward air deflector hood constructed of 20 ga. cold rolled steel with baked-on gray-green polyester powder paint.
- J.20. 90° non-velocity generating downward air deflector hood constructed of 20 ga. cold rolled steel with baked-on gray-green polyester powder paint.
- J.21. (opt) A 208V to 115V step down shall be provided for operation of the 115V unit (HDS/HDC/PTS models).
- J.22. (opt) A 230V to 115V step down shall be provided for operation of the 115V unit (HDS/HDC/PTS models).
- J.23. (opt) A 460V to 115V step down shall be provided for operation of the 115V unit (HDS/HDC/PTS models).
- J.24. (opt) A 575V to 115V step down shall be provided for operation of the 115V unit (HDS/HDC/PTS models).
- J.25. A 208V to 115V step down shall be provided for operation of the 115V power exhauster and control circuit. (BTS model)
- J.26. A 230V to 115V step down shall be provided for operation of the 115V power exhauster and control circuit. (BTS model)
- J.27. A 460V to 115V step down shall be provided for operation of the 115V power exhauster and control circuit. (BTS model)
- J.28. A 575V to 115V step down shall be provided for operation of the 115V power exhauster and control circuit. (BTS model)
- J.29. A horizontal concentric vent kit shall be provided to allow the vent outlet and combustion air inlet pipes to penetrate the building wall through one opening.
- J.30. A vertical concentric vent kit shall be provided to allow the vent outlet and combustion air inlet pipes to penetrate the building roof through one opening.

K. Thermostats

The unit shall be provided with the following thermostat:

- K.2. A single stage room thermostat with a 50°-90°F range.
- K.3. A field installed single stage room thermostat with a 50°-90°F temperature set point range. The stat shall also include switching for Heat/Off and Fan On/Auto control.
- K.4. Honeywell TH5220D1029 digital non-programmable room stat with switching - range 40-90°F.
- K.5. A field installed two-stage duct thermostat with a 0°-100°F range and 20-foot capillary.
- K.6. A two-stage electronic duct thermostat with field installed temperature sensor, temperature selector and one stage adder.

Figure 23.1 - Model Number Designations

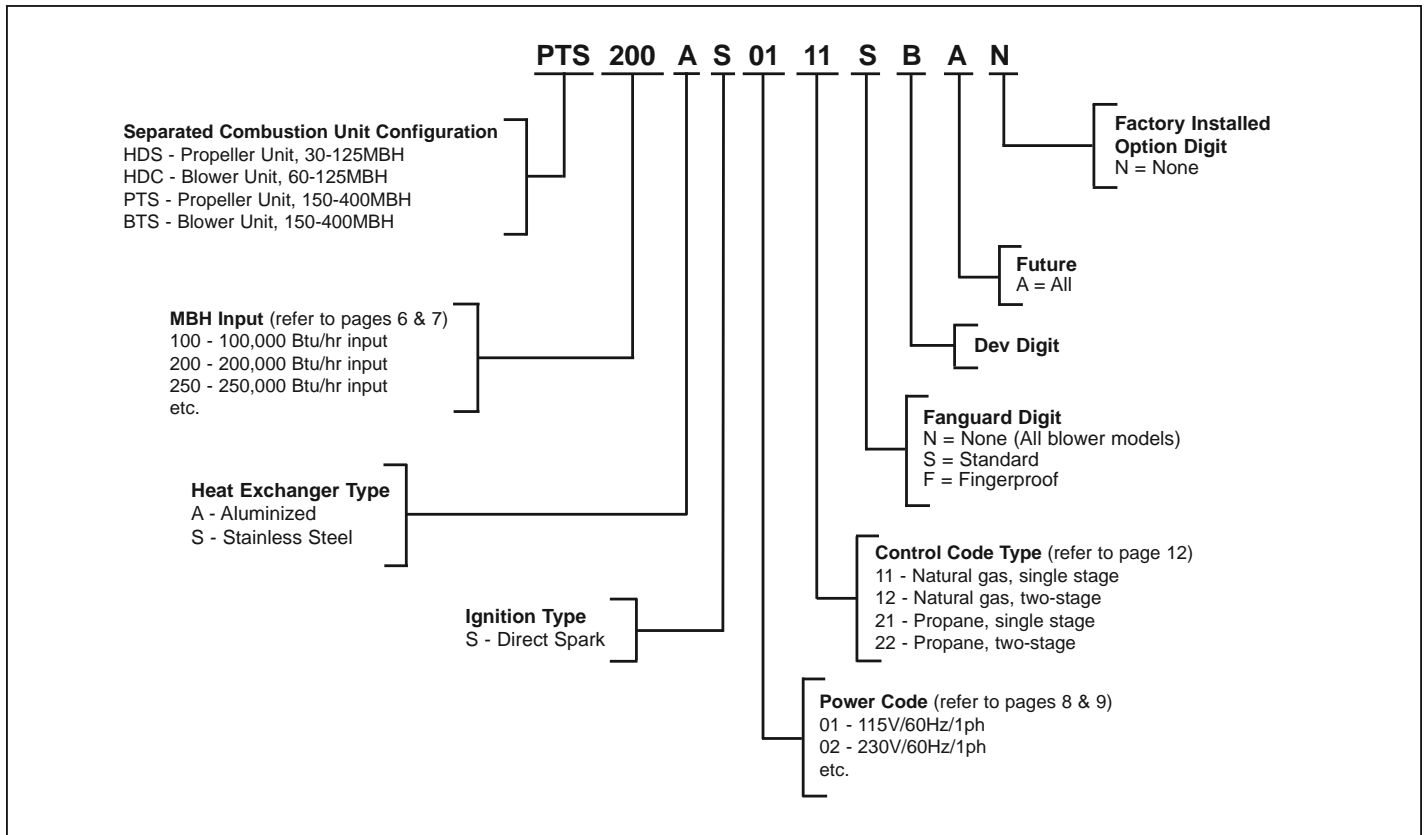

Products from Modine are designed to provide indoor air-comfort and ventilation solutions for residential, commercial, institutional and industrial applications. Whatever your heating, ventilating and air conditioning requirements, Modine has the product to satisfy your needs, including:

HVAC

- Unit Heaters:
 - Gas
 - Hydronic
 - Electric
 - Oil
- Ceiling Cassettes
- Duct Furnaces
- Hydronic Cabinet Unit Heaters, Fin Tube, Convectors
- Infrared Heaters
- Make-up Air Systems
- Unit Ventilators

Ventilation

- Packaged Rooftop Ventilation

School Products

- Vertical Packaged Classroom HVAC:
 - DX Cooling/Heat Pump
 - Water/Ground Source Heat Pump
 - Horizontal/Vertical Unit Ventilators

Geothermal

- Water-to-Water
- Water-to-Air
- Combination

Specific catalogs are available for each product. Catalogs 75-136 and 75-137 provide details on all Modine HVAC equipment.



Modine Manufacturing Company

1500 DeKoven Avenue
Racine, Wisconsin 53403-2552
Phone: 1.800.828.4328 (HEAT)
www.modinehvac.com

© Modine Manufacturing Company 2017