

CRPWREXH030A01
 CRPWREXH021A01
 CRPWREXH022A01
 CRPWREXH023A01
 CRPWREXH080A00
 CRPWREXH081A00

For Use With Vertical
 EconoMiSer™ IV, EconoMiSer™ 2 or
 EconoMiSer™ X Only

**SMALL ROOFTOP UNITS
 ACCESSORY VERTICAL POWER EXHAUST
 GAS HEATING/ELECTRIC COOLING,
 ELECTRIC COOLING, AND HEAT PUMP UNITS
 3 TO 15 TON**

Installation Instructions

TABLE OF CONTENTS

PACKAGE CONTENT.....1
 UNIT CONFIGURATION TABLE.....1
 PACKAGE USAGE.....1
 SAFETY CONSIDERATIONS.....1
 GENERAL.....1
 INSTALLATION.....2-10
 Power Exhaust Wiring with EconoMiSer IV.....6
 Power Exhaust Wiring with EconoMiSer2
 and PremierLink™ Controller or RTU-MP/OPEN.....7
 Power Exhaust Wiring with EconoMiSer X.....6
 Attaching Power Exhaust to the Unit.....8
 Install Hinged Door Angle
 (Small & Large Cabinet).....10
 Operational Notes for Testing Purposes -
 PremierLink.....11

IMPORTANT: Read these instructions completely before attempting to install this accessory.

PACKAGE CONTENTS

QTY	CONTENTS
1	Power Exhaust Hood/Fan Assembly ²
1	Low Voltage Wiring Harness with plug and 12 in (305mm) gray jumper wire ²
1	High Voltage Wiring Harness with plug ²
8	No. 10 x 3/4 in. (19mm) Mounting Screws
1	Gasketing Roll
1	Sealing Angle ¹

NOTES:

- The sealing angle was included beginning with unit serial numbers 3502Gxxxxx (21A-23A and 30A power exhaust only). For use with Hinged Panel Units only.
- Both wiring harnesses are shipped attached to the power exhaust assembly.

UNIT CONFIGURATION TABLE

UNIT CONFIGURATION	UNIT FOOTPRINT SIZE
Small Cabinet	46 3/4" x 74 3/8"
Large Cabinet	58 1/2" x 88 1/8"
Extra Large Cabinet	63 3/8" x 115 7/8"

PACKAGE USAGE

UNIT CONFIGURATION	POWER EXHAUST PART NUMBER	POWER EXHAUST VOLTAGE
Small Cabinet	CRPWREXH030A01	208/230 V, 1 Ph
	CRPWREXH021A01	460 V, 3 Ph
Large Cabinet	CRPWREXH022A01	208/230 V, 1 Ph
	CRPWREXH023A01	460 V, 3 Ph
Extra Large Cabinet	CRPWREXH080A00	208/230 V, 1 Ph
	CRPWREXH081A00	460 V, 3 Ph

SAFETY CONSIDERATIONS

Installation and servicing of air-conditioning equipment can be hazardous due to system pressure and electrical components. Only trained and qualified service personnel should install, repair, or service air-conditioning equipment.

Untrained personnel can perform the basic maintenance functions of replacing filters. All other operations should be performed by trained service personnel. When working on air-conditioning equipment, observe precautions in the literature, tags, and labels attached to the unit, and other safety precautions that may apply.

Follow all safety codes. Wear safety glasses and work gloves.

Recognize safety information. This is the safety-alert symbol . When you see this symbol on the unit and in instructions or manuals, be alert to the potential for personal injury.

Understand these signal words; DANGER, WARNING, and CAUTION. These words are used with the safety-alert symbol. DANGER identifies the most serious hazards which **will** result in severe personal injury or death. WARNING signifies hazards which **could** result in personal injury or death. CAUTION is used to identify unsafe practices which **may** result in minor personal injury or product and property damage. NOTE is used to highlight suggestions which will result in enhanced installation, reliability, or operation.

GENERAL

The accessory vertical power exhaust is used in conjunction with the vertical EconoMiSer IV, EconoMiSer X, or EconoMiSer2 accessories. For horizontal applications, this power exhaust accessory **cannot** be used. The horizontal power exhaust accessory must be used for horizontal applications.

See Table 1 and 2 for EconoMiSer usage. See Fig. 1 for dimensions.

Table 1 - Economizer Accessory Use

PART NUMBER	DESCRIPTION
CRECOMZR020A02 CRECOMZR021A03 CRECOMZR062A00	EconoMi\$er IV with W7212 Controller
CRECOMZR022A01 CRECOMZR022B00 CRECOMZR023A00 CRECOMZR023B00 CRECOMZR068A00 CRECOMZR063A00 CRECOMZR070A00	EconoMi\$er2 without controller. (Typically used with PremierLink or a field-supplied building management system)
CRECOMZR069A00 CRECOMZR071A00 CRECOMZR078A00 CRECOMZR080A00 CRECOMZR067A00	EconoMi\$er X with W7220 Controller

Table 2 - Factory-Installed Vertical EconoMi\$er Use

BASE RAIL SERIAL	DESCRIPTION
From 4005Gxxxxx to current	EconoMi\$er IV with W7212 controller
From 0802Gxxxxx to current	EconoMi\$er2 without controller (used with PremierLink or field-supplied building management system).

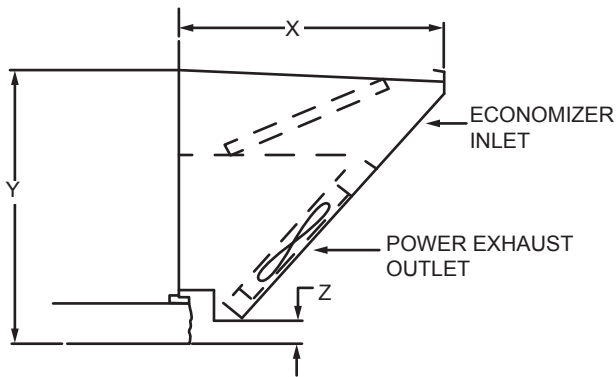

UNIT CONFIGURATION	X	Y	Z
Small Cabinet	18.5 (470)	19.25 (515)	7/16 (11)
Large Cabinet	26 (660)	25 (635)	0 (0)
Extra Large Cabinet	28.6 (725)	37.75 (960)	4.5 (115)

Figure 1 - Dimensions, EconoMi\$er with Power Exhaust

INSTALLATION

IMPORTANT: Follow all applicable local and national electrical codes when installing this accessory.

Follow all local and NEC (National Electrical Code) codes. If a single power source is to be used, size the wire to include power exhaust MCA and MOCP. (See Table 3.)

Table 3 - Power Exhaust Electrical Data

POWER EXHAUST PART NO.	MCA (230v)	MCA (460v)	MCA (575v)	MOCP (for separate power source)
CRPWREXH030A01	1.5	N/A	0.64	15
CRPWREXH021A01	N/A	0.9	N/A	15
CRPWREXH022A01 CRPWREXH080A00	3.3	N/A	1.32	15
CRPWREXH023A01 CRPWREXH081A00	N/A	1.8	N/A	15

LEGEND

MCA - Minimum Circuit Amps
MOCP - Maximum Overcurrent Protection
N/A - Not Applicable

NOTE: For R-410A units, refer to unit nameplate for MCA and MOCP for installed power exhaust. For R-22 units, use the calculations detailed below.

Check MCA and MOCP when power exhaust is powered through the unit (must be in accordance with NEC and/or local codes). Determine the new MCA including the power exhaust using the following formula:
 MCA New = MCA unit only + MCA of Power Exhaust

For example, using a R-22 gas heat, electric cooling, 6-ton unit with MCA = 28.9 and MOCP = 35, with CRPWREXH030A01 power exhaust. MCA New = 28.9 amps + 1.5 amps = 30.4 amps

If the new MCA does not exceed the published MOCP, the MOCP would not change. The MOCP in this example is 35 amps, the MCA New is below 35, therefore the MOCP is acceptable. If "MCA New" is larger than the published MOCP, raise the MOCP to the next larger size. For separate power, the MOCP for the power exhaust will be 15 amps per NEC.

NOTE: For 575-v installations, a field-supplied and installed transformer (part no. HT01AH859) must be used with 208/230-v power exhaust. (See Fig. 6.)

The vertical power exhaust can be used with 3 different types of EconoMi\$ers. While the physical installation of the power exhaust assembly stays the same, the wiring differs between the two EconoMi\$er types. These instructions will clearly describe the installation and wiring for each type. The 3 types are:

- EconoMi\$er IV with controller W7212
- EconoMi\$er2 without controller. It is generally used with a separate PremierLink controller or a field-supplied building management system.
- EconoMi\$er X with controller W7220.

To install the vertical power exhaust, perform the following procedure:

1. Turn off unit power supply and install lockout tag. for gas units, turn off the gas supply.

⚠ WARNING

ELECTRICAL SHOCK HAZARD
Failure to follow this warning could cause personal injury and/or death.
Before beginning any modification, be certain that the main-line electrical disconnect switch is in the OFF position. Close the main gas supply shutoff valve. Tag disconnect switch and gas valve with suitable warning labels.

NOTE: Before installing, ensure voltage of power exhaust agrees with power supply to the equipment.

2. Remove the power exhaust knockout plugs located on the lower left side of the EconoMiSer. (See Fig. 2.)

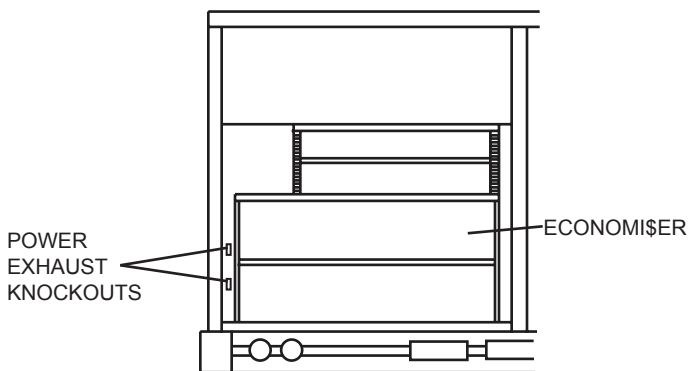

Figure 2 - Power Exhaust Knockout Location

3. Remove the RTU unit filter panel to allow access to the inside of the rooftop.
4. The panel covering the horizontal return opening on the unit may also be removed for easier access and installation. Be sure to replace this panel when installation is complete.
5. Install the vertical EconoMiSer per the instructions provided with the EconoMiSer. Do not install the rainhood shipped with the EconoMiSer. Set aside the aluminum air filter for use with the power exhaust.
6. Remove fan shield so power exhaust can lay flat without bending the shield or damaging the roof.
7. Remove the shipping blocks from the bottom of the accessory vertical power exhaust. (See Fig. 3.)

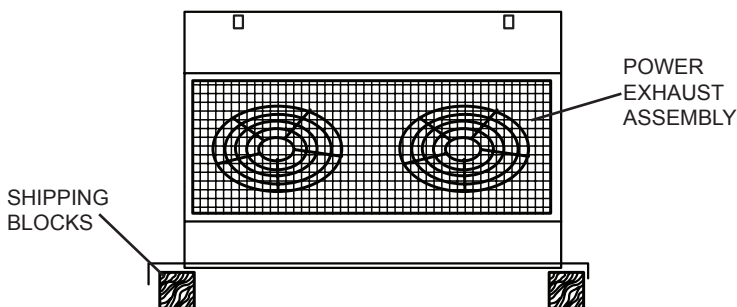

Figure 3 - Shipping Block Removal

8. There may be a hinged door panel in place of the filter panel. Open the hinged door, remove the screws and hinges, remove the door and set it aside. Keep all screws and hinges.
9. Place the power exhaust close to the EconoMiSer to allow for wiring harness connection.

⚠ CAUTION

UNIT DAMAGE HAZARD
Failure to follow this caution may result in equipment damage.
Be careful to route wires to avoid pinching or cutting during assembly. It can be difficult to protect the wires while attaching the power exhaust to the unit.

10. Follow the wiring instructions specific to the EconoMiSer. Be sure power exhaust wiring does not interfere with damper operation.

Power Exhaust Wiring with EconoMiSer IV and EconoMiSer X

Use these instructions and diagrams if using the vertical power exhaust with EconoMiSer IV and EconoMiSer X.

1. The 2-wire low voltage harness from the power exhaust and the 24 to 36 in (610 or 915 mm) low voltage extension harness are plugged together for shipping. Unplug these 2 harnesses for installation.
2. Insert the 2-wire low voltage harness plug from the power exhaust into the top knockout on the EconoMiSer. (See Fig. 2.)
3. From the rear of the EconoMiSer, connect the 24 in (601mm) long low voltage extension harness plug to the power exhaust harness.
4. For EconoMiSer IV: Route the other end of the low voltage extension harness to the EconoMiSer IV controller. (See Fig. 4.) The harness is connected to the controller by connecting the tan wire to the tan wire 24 VAC COM terminal on the controller. The terminal on the gray wire is connected to terminal EF1 on the controller. See Fig. 7 and 8 for EconoMiSer wiring diagrams. Install the gray jumper wire on the controller from the exhaust fan terminal (EF), to the 24 VAC HOT terminals. The gray jumper is shipped wire tied to the control harness.

For EconoMiSer X: Route the other end of the low voltage extension harness to the EconoMiSer X 12 pin plug, (PL6). The gray wire from the low voltage extension harness connects to the yellow wire coming from terminal 8 in the 12 pin plug. The tan wire from the low voltage extension harness connect to the brown wire coming from terminal 4 in the 12 pin plug. See diagrams 7 and 8 for EconoMiSer X wiring diagrams.

5. The high voltage harness from the power exhaust and the high voltage extension harness are plugged together for shipping. Unplug these 2 harnesses for installation.
6. Insert the high voltage harness plug from the power exhaust into the bottom knockout on the EconoMiSer. (See Figs. 2 and 4.)

R-410A Rooftop Models Only - For single point wiring application, connect the power exhaust power wire harness to the compressor contactor or indoor fan contactor in the control box. Install the power exhaust power wire harness into the pressure lugs on the compressor contactor or indoor fan contactor, used for the field power wiring also.

Proceed to steps 7 and 8 for details on completing connection and routing.

7. From the rear of the EconoMiSer, connect the long high voltage extension harness plug to the power exhaust harness. (See Figs. 4, 5, and 6.)
8. Route the other end of the long high voltage extension harness through the HVAC unit to the control box. (See Fig. 6.) The harness

must be routed through the grommets provided in the unit. Do not drill routing holes. Be careful not to route the power exhaust harness on top of the indoor coil. Wire the end of the high voltage harness extension to the power exhaust power source. (See Fig. 7 and 8.)

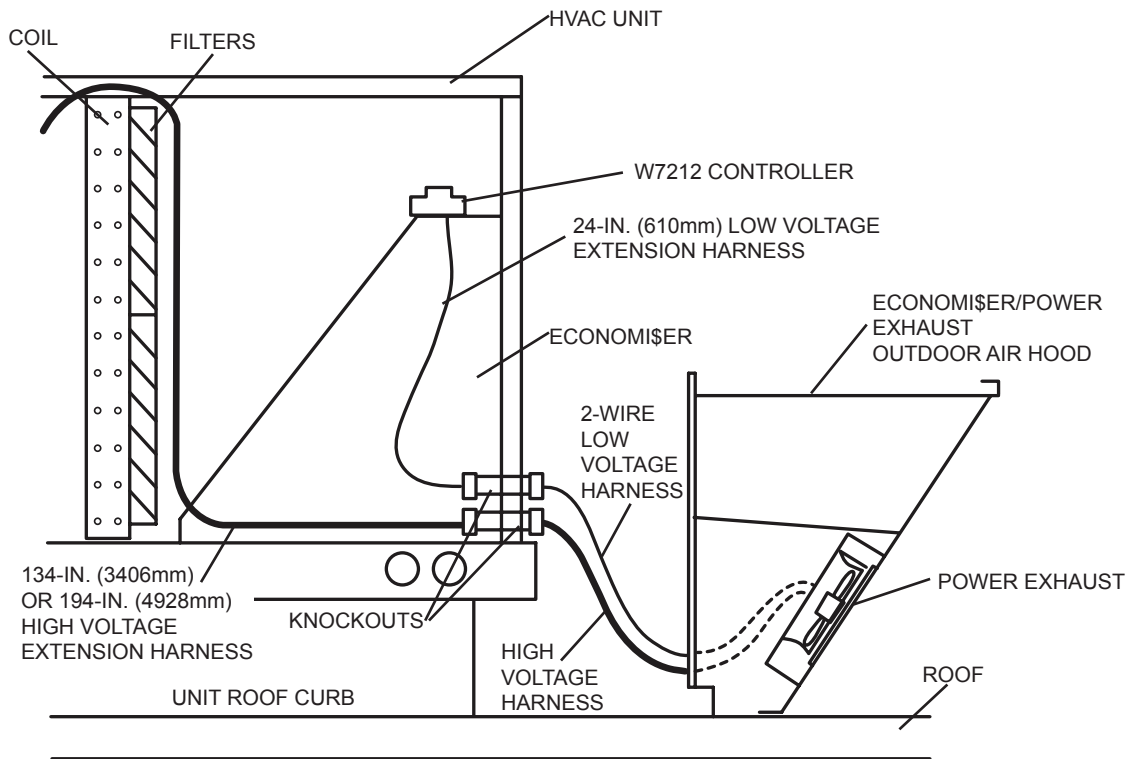

Figure 4 - Power Exhaust Harness Installation for EconoMiSer IV with W7212 Controller

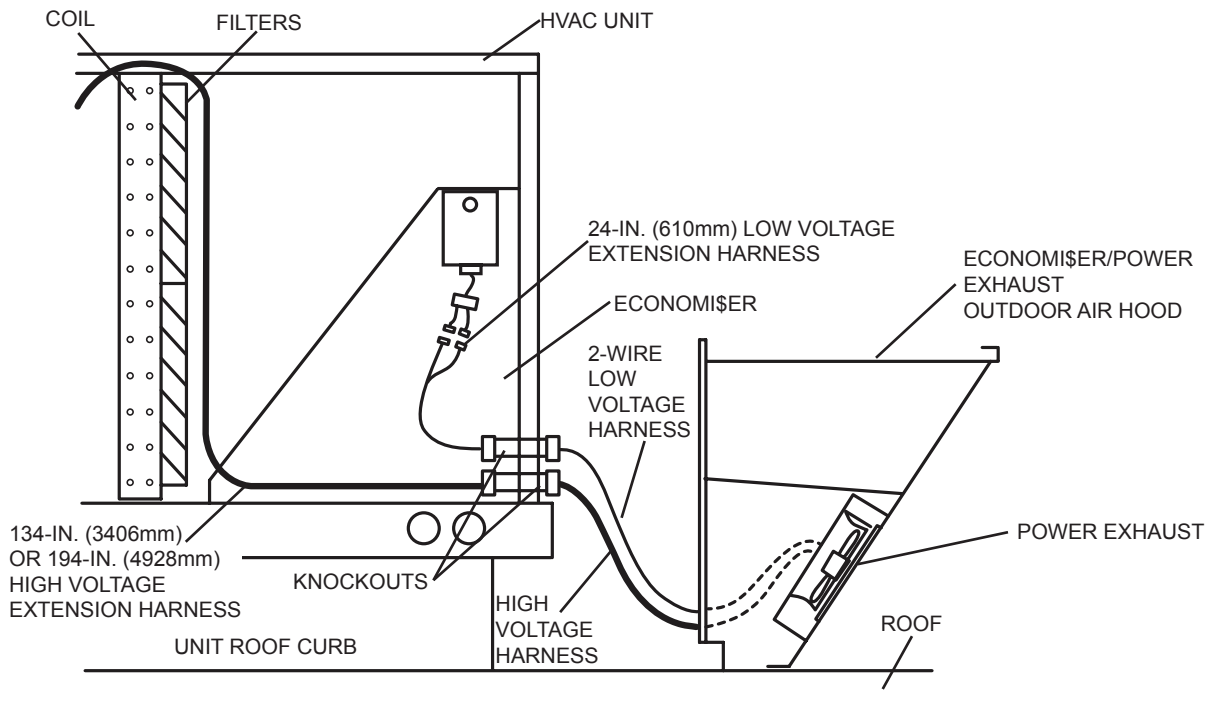

Figure 5 - Power Exhaust Harness Installation for EconoMiSer X with W7220 Controller

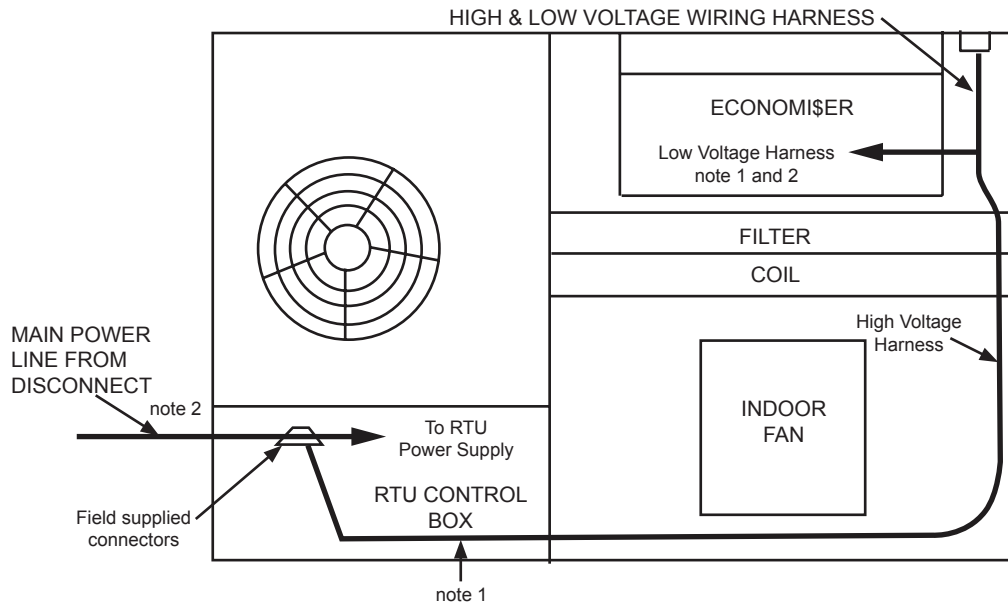
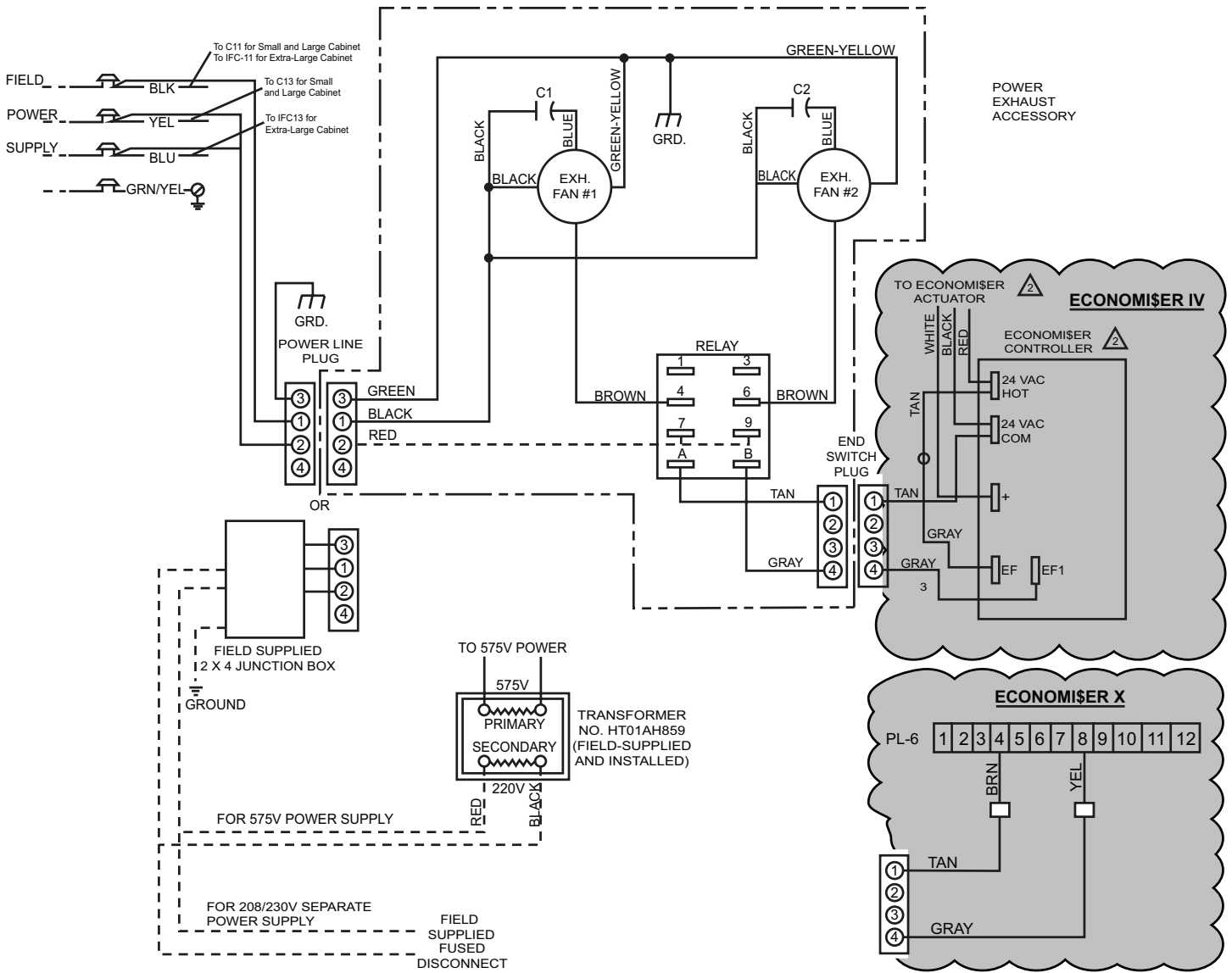

Figure 6 - Power Line Harness Routing (Top View of Unit Shown)

NOTES:

1. The power exhaust comes with short (24" or 36") low voltage extension harness. Economi\$er2 includes a longer low voltage harness which is to be used to route back through unit to RTU controller in RTU control box. Use sperate knockout for high and low voltage wires.
2. Low voltage wires are Economi\$er X attach to wire leads on Economi\$er X plug.
3. Ensure main power line, disconnect and fuse/breaker are sized per National Electric Code.



--- Field Supplied Wiring

- ⚠ 575 V transformer No. HT01AH859 is ordered separately from power exhaust
- ⚠ Economizer actuator and controller are shipped with the Economizer - not with power exhaust.
- ⚠ Connections from End Switch plug to Economizer controller are made by installer.
- ⚠ If a single power source is to be used, size wire to include power exhaust MCA and MOCP.
 For R-410A units, refer to the unit nameplate for MCA and MOCP for installed power exhaust.
 For R-22 units use the following calculations
 Check MCA and MOCP when power exhaust is powered through the unit. Determine the new MCA including the power exhaust using the following formula:
 $MCA_{New} = MCA_{unit\ only} + MCA_{of\ Power\ Exhaust}$
 For example, using an electric cooling, 6-ton R-22 unit with $MCA = 28.9$ and $MOCP = 35$, with CRPWREXJ030A01 power exhaust.
 $MCA_{New} = 28.9\ amps + 1.5\ amps = 30.4\ amps$
 If the new MCA does not go over the MOCP published, then MOCP will not change. The MOCP in this example is 35 amps, the MCA New is below 35, therefore the MOCP is OK. If "MCA NEW" is larger than the published MOCP, raise the MOCP to the next larger size. For separate power, the MOCP for the power exhaust will be 15 amps per NEC.

Figure 7 - Power Exhaust Wiring for EconoMiSer IV and EconoMiSer X - 208/230 V and 575 V Units

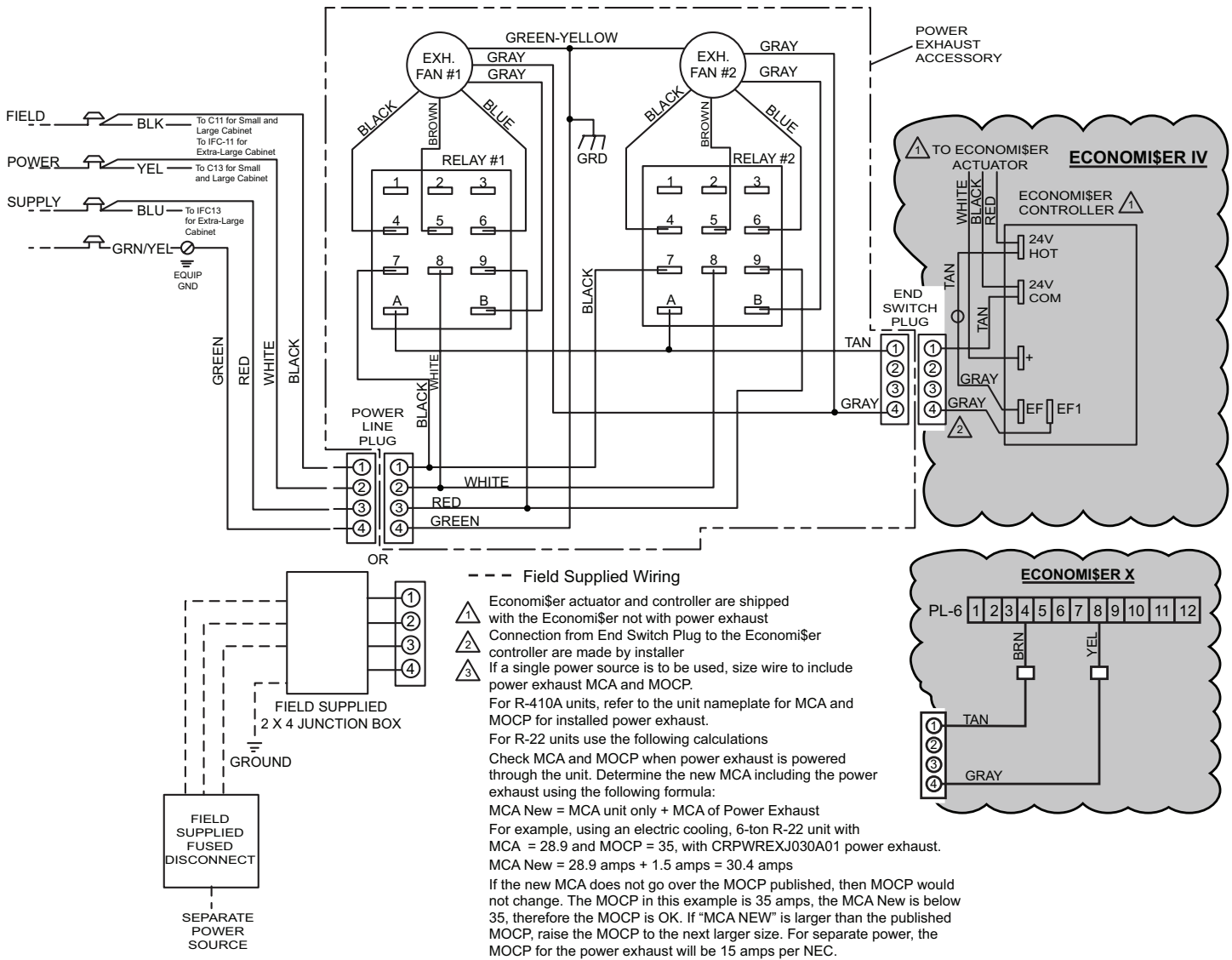

Figure 8 - Power Exhaust Wiring for EconoMiSer IV and EconoMiSer X with Controller W7212-460 V Units

Power Exhaust Wiring with EconoMiSer and PremierLink Controller or RTU-MP/OPEN

Use these instructions when installing the vertical power exhaust with EconoMiSer2 and PremierLink or RTU-MP/OPEN controller.

1. A low voltage extension harness is supplied with the EconoMiSer2 (without controller) beginning with unit serial number 2703Gxxxxx. Prior to serial 2703Gxxxxx, the supplied low voltage extension harness is not long enough to reach the PremierLink control board and will have to be field extended. The two-wire low voltage harness and the low voltage extension harness are wire tied together for shipping. Separate the harnesses for installation and discard the short low voltage extension harness supplied with power exhaust.
2. Insert the 2-wire low voltage harness plug from the power exhaust into the top knockout on the EconoMiSer2. (See Fig. 2 and 9.)
3. From the rear of the EconoMiSer2, connect the low voltage extension harness plug to the two-wire harness from the power exhaust. (See Fig. 9.)

4. Route the other end of the low voltage extension harness to the PremierLink controller. (See Fig. 9.)
5. The high voltage harness from the power exhaust and the high voltage extension harness are plugged together for shipping. Unplug these 2 harnesses for installation.
6. Insert the high voltage harness plug from the power exhaust into the bottom knockout on the EconoMiSer2. (See Fig. 2 and 9.)
7. From the rear of the EconoMiSer2, connect the long high voltage extension harness plug to the power exhaust harness. (See Fig. 9.)
8. Route the other end of the long high voltage extension harness through the HVAC unit to the control box. (See Fig. 6.) The harness must be routed through the grommets provided in the unit. Do not drill routing holes. Be careful not to route the power exhaust harness on top of the indoor coil.

9. Wire the end of the high voltage harness extension to the power exhaust power source.
10. **Field-Installed PremierLink Control** (See Fig. 10.) Connect the gray wire from the low voltage extension harness to J8-3 and the tan wire to common terminal. Common is available from PremierLink terminal J1 or the common side of the unit control power transformer (the brown leads that go to unit ground). The other end of the harness is connected to the power exhaust wiring.

NOTE: When the PremierLink board is configured for a heat pump, it does not require the HS3/EXH/RVS, allowing this terminal to be used for the power exhaust.

TB2-15 (Small & Large Cabinet) or TB3-15 (Extra Large Cabinet) located in the low voltage section to the left of the control box. The gray wire from the harness should be routed and wired to TB2-15 or TB3-15. The tan wire should be routed and wired to the Central Terminal Board Thermostat Terminal C (Common).

RTU-MP/OPEN Control

Connect the gray wire from the low voltage harness extension to J11-3 and the tan wire to the Central Terminal Board Thermostat Terminal C (Common).

Factory-Installed PremierLink Control

The PremierLink J8-3 terminal is factory wired to a terminal board

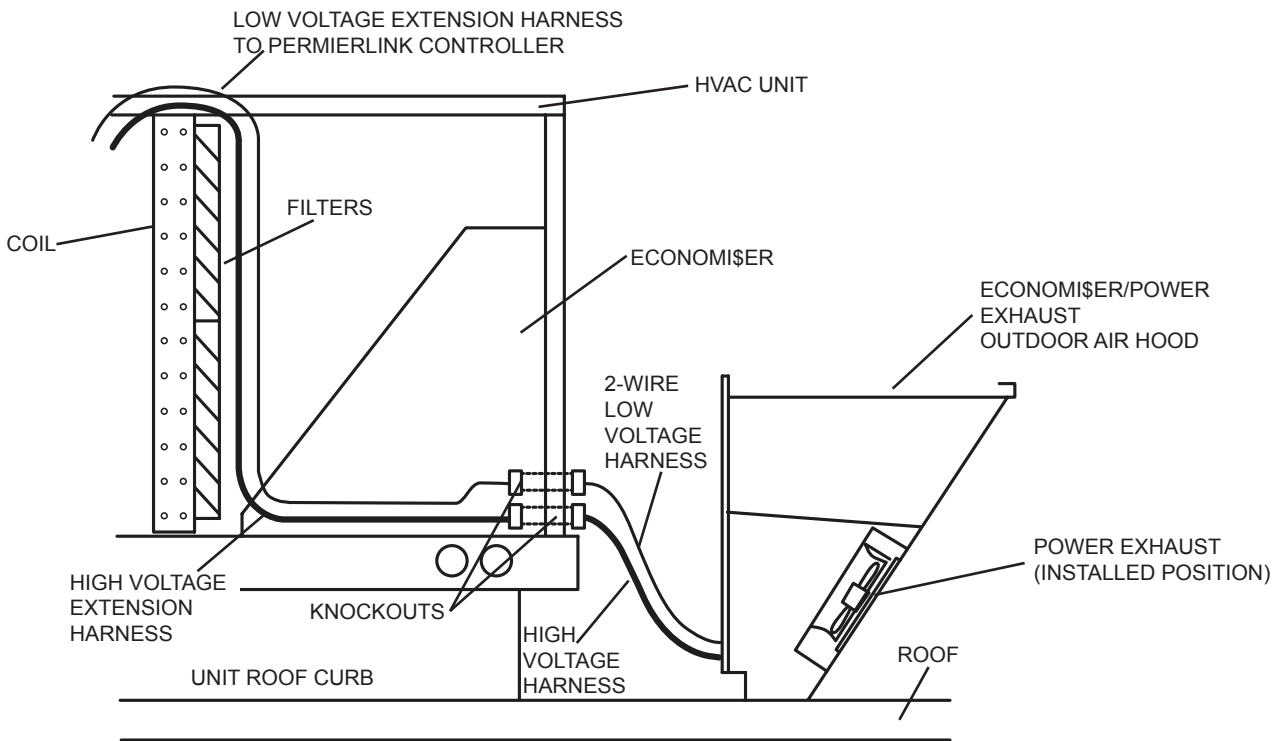

Figure 9 - Power Exhaust Harness Installation with EconoMiSer2 and PremierLink Controls

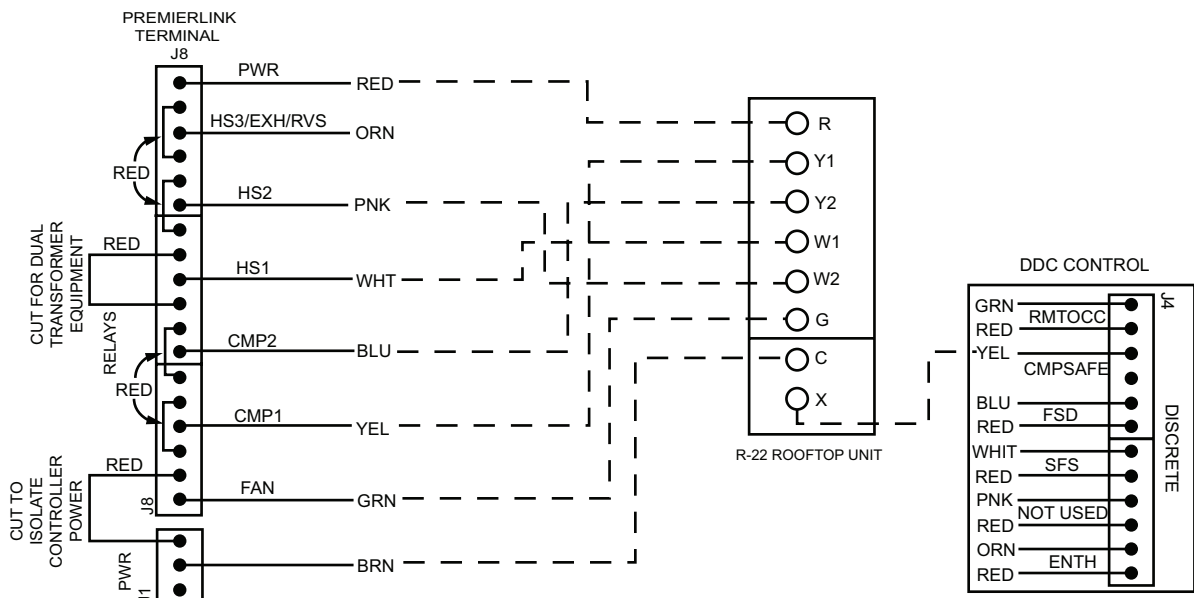
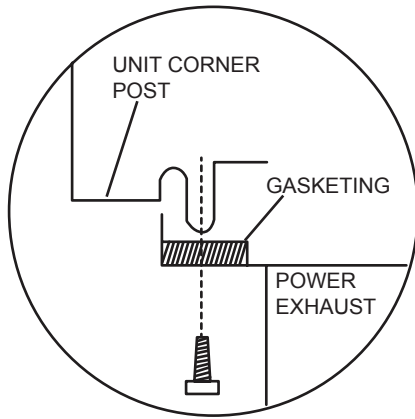

Figure 10 - Typical PremierLink Control Wiring To Rooftop R-22 Units

Attaching Power Exhaust to the Unit

1. Make sure all power exhaust harness are connected as indicated in the previous steps. See Fig. 7 and 8.
2. Make sure all wiring is secure. Use field-supplied wire ties if necessary. Be sure that wiring does not interfere with operation of the HVAC unit, EconoMiSer, or power exhaust.
3. For units with a standard filter panel (i.e., no hinged door): Install the gasketing (provided) on the back of power exhaust side mating flanges. (See Fig. 11.)
NOTE: This step does not apply to units with a hinged door.
4. Lift power exhaust and install over EconoMiSer using the #10 x 3/4 in. long screws provided. Make sure wiring harnesses are properly secured. (See Fig. 12.)
5. Locate the aluminum filter shipped with the EconoMiSer. Open



**Figure 11 - Gasketing Location Detail
(Standard Filter Panel Only)**

the filter clips under the top hood of the power exhaust. Slide aluminum filter into the outside air opening of the power exhaust. Filter will slide past filter clips. Close filter clips, which will lock filter in place.

6. Reinstall the fan shield.
7. Return power to unit and remove lockout tag.

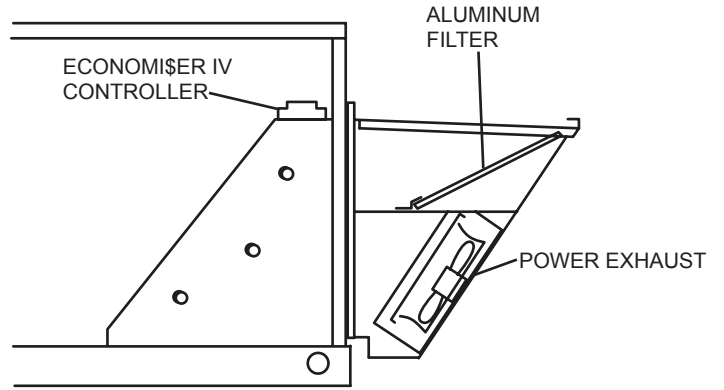

Figure 12 - Power Exhaust Installed on Unit

8. Test power exhaust operation by setting the power exhaust set point on the EconoMiSer controller to 0%. Power exhaust performance is shown in Fig. 13.
9. Adjust the power exhaust set point on the EconoMiSer controller to the desired activation point per unit schematic.
10. For units with a standard filter access panel, reinstall the unit filter access door.

For units with a hinged access door (Small & Large Cabinet), install the hinged door seal angle included in the power exhaust kit using the instructions in this instruction. Do not proceed unless the sealing angle is installed. Units with a hinged door that do not have a sealing angle may not have a watertight seal.

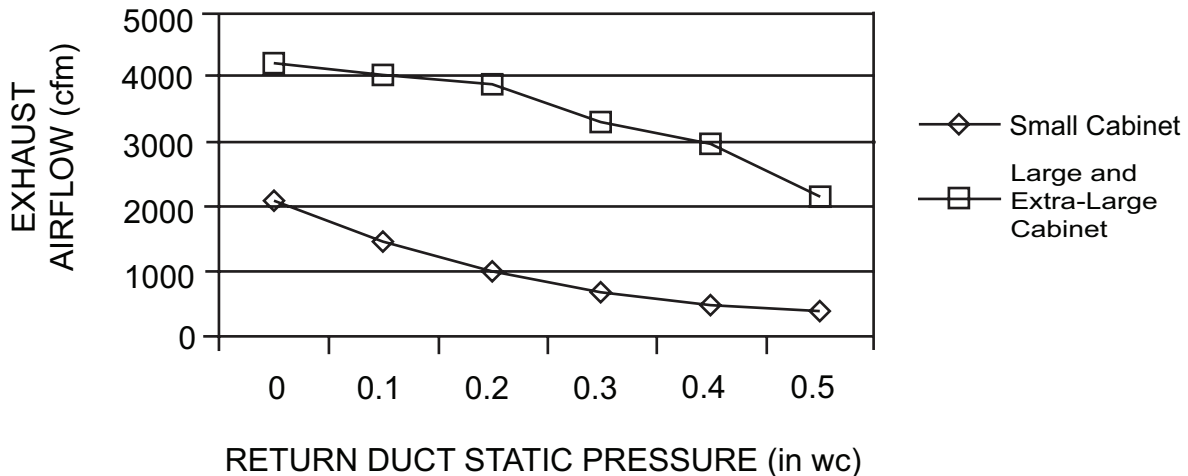

Figure 13 - Power Exhaust Performance

Install the Hinged Door Angle (Small and Large Cabinet)

Follow these instructions if the unit has a hinged panel instead of a standard filter panel. Hinged Door Angle CRPECONV003A00 is for small cabinets and CRPECONV004A00 is for large cabinets.

NOTE: A separate hinged door angle kit must be ordered for the extra-large cabinet

1. Find the sealing angle and three screws provided in the power exhaust kit.
2. Attach the sealing angle to the top of the power exhaust hood using the screws provided. Refer to Fig. 14. Note that the gasketing flange will be facing out.
3. *If there are NO pre-drilled holes in the Power Exhaust hood:* Lay the hinged panel, insulation side up, on top of the hood so that the hinge screw holes align with the pre-drilled screw holes in the sealing angle. (For hoods with pre-drilled holes, skip to Step 7.)
4. Check the alignment of the hinged door with the side of the filter opening to be sure it will close properly.
5. Use a pencil to mark the hood where the screw holes will be.
6. Remove the hinged door and drill four (4) 11/64 in. holes where the marks are.

NOTE: The sealing angle will be in place; use the holes in it as a guide.

7. Place the door and hinges back on the unit. Screw through the door hinges and sealing angle into the flanged top of the hood using the 4 screws set aside when the hinged door was removed. (See Fig. 16.)
8. Close the hinged door and adjust handle if necessary.

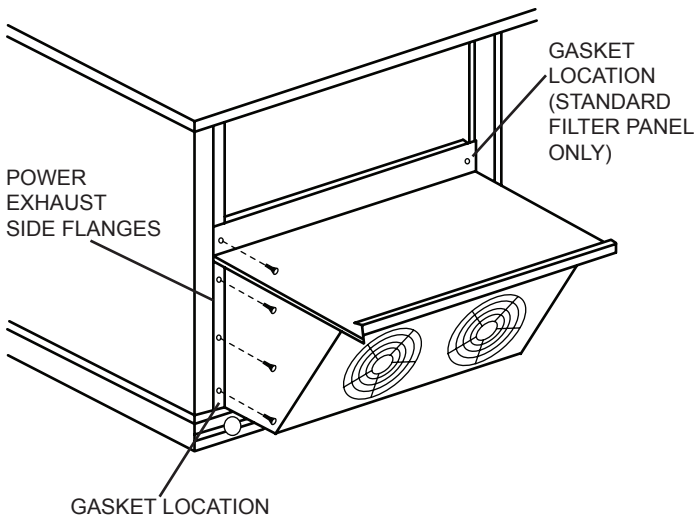

Figure 14 - Power Exhaust Installation

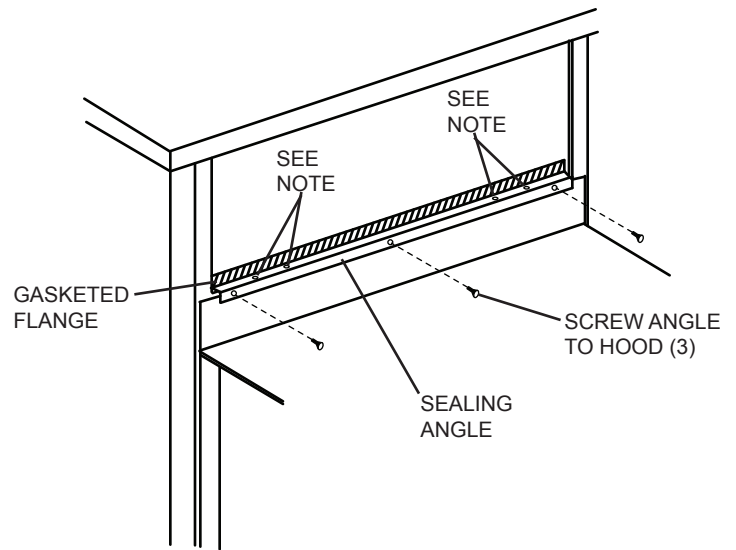

Figure 15 - Install Sealing Angle

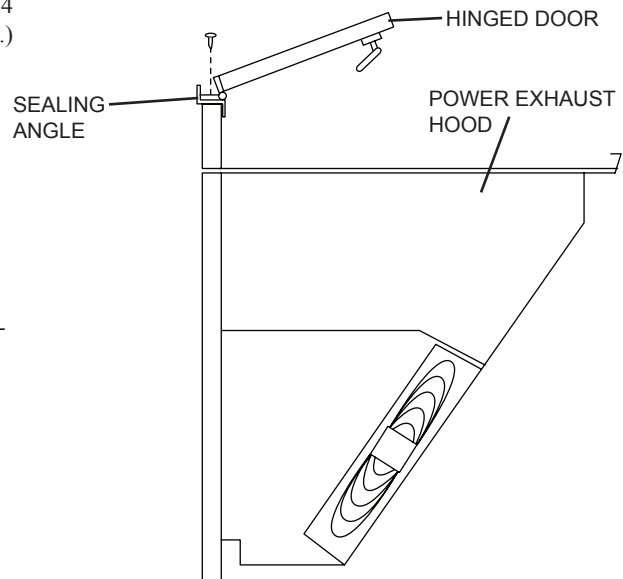

Figure 16 - Install the Hinged Door

Operational Notes for Testing Purposes - PremierLink

If the "continuous power exhaust" function is disabled, the power exhaust fan will operate during EconoMiSer purge cycles when the EconoMiSer damper position is above the configured minimum value. If enabled, the power exhaust fan will follow the supply fan's operation for PremierLink version 1.2 and will follow the occupancy configuration for PremierLink version 1.3.

The PremierLink "Auxiliary Output" function defines the specific use of the auxiliary output (HS3/EXH/RVS) for the power exhaust. The output will be energized or deenergized by the appropriate algorithm that uses that specific output.

A setting of 1 = Exhaust fan output.

The Power Exhaust set point in the set point table determines the power exhaust damper "percent open" when the power exhaust is energized. The damper percentage set point has a 10% hysteresis.

If "Continuous" in the service configuration table is set to "enable", the power exhaust output will energize when occupied (for PremierLink controls version 1.3 and later) and will be energized when the supply fan relay is on (for versions prior than 1.3).