

SV9541, SV9641 SmartValve™ System Controls

INSTALLATION INSTRUCTIONS

APPLICATION

The TRADELINE® SV9541 and SV9641 SmartValve™ System Controls combine gas flow control and electronic intermittent pilot sequencing functions into a single unit. The Q3450 or Q3480 Pilot hardware supplies the low voltage igniter, flame sensor and pilot burner. These ignition system controls provide all gas ignition safety functions by controlling gas flow, ignition source, and a 120 Vac or 240 Vac combustion air blower. The controls also monitor the appliance airflow proving switch and limit string to assure proper appliance operation, and provide prepurge, postpurge, and timed trial for pilot ignition with 100 percent shutoff and continuous retry. A diagnostic LED indicates system status.

These controls communicate directly with an electronic fan timer (ST9160 Electronic Fan Timer for single stage applications; ST9162 Electronic Fan Timer for two-stage applications) in typical forced warm air furnace applications. They also interface with the 208907

Terminal Board, providing compatibility with power stealing thermostats. Or, they directly interface with the appropriate power supplies and a system thermostat for additional appliance applications. When controlled directly by a thermostat, these controls do not provide a postpurge function, because power to the control is removed when the thermostat call for heat ends.

The SV9541 and SV9641 Systems are suitable for a wide range of fan-assisted combustion gas-fired appliances including furnaces, rooftop furnaces, boilers, unit heaters, infrared heaters, water heaters and commercial cooking appliances. The specific application of the SmartValve™ System is determined by the appliance manufacturer.

SmartValve™ System controls are available in a range of valve capacities, see Table 1. (Table 2 provides gas capacity conversion factors.) The suffix letter indicates temperature range and regulator type, see Table 3.

Table 1. Valve Capacity^a.

Model	Size (Inlet x Outlet) (in.)	AGA Certified Capacity for Natural Gas		AGA Certified Minimum Regulation for Natural Gas		AGA Certified Maximum Regulation for Natural Gas	
		ft ³ /hr	m ³ /hr	ft ³ /hr	m ³ /hr	ft ³ /hr	m ³ /hr
SV9541	1/2 x 1/2	150	4.2	20 ^d	0.6	200	5.7
SV9641 ^{b,c}	3/4 x 3/4	300	8.5			415	11.8

^a Capacity based on 1000 Btu/ft³, 0.64 sp gr natural gas at 1 in. wc pressure drop (37.3 MJ/m³, 0.6 sp gr natural gas at 0.25 kPa pressure drop).

^b Capacity is reduced by 5 percent when using an outlet screen.

^c Valves are guaranteed at only 77 percent of the rating.

^d Minimum regulation for LP gas is 40,000 Btuh.

Table 2. Gas Capacity Conversion Factor.

Gas	Specific Gravity	Multiply Listed Capacities By
Manufactured	0.60	0.516
Mixed	0.70	0.765
Propane	1.53	1.62

Table 3. Model Number Suffix Letter Designation.

Model No. Suffix Letter	Ambient Temperature Range	Pressure Regulator Type
M	-40°F to 175°F (-40°C to 79°C)	Standard
Q		Two-stage



SPECIFICATIONS

IMPORTANT

These ignition system controls provide only direct replacement. See Table 12 for a list of controls these replace. Use the Y8610 to convert standing pilot systems to electronic ignition systems.

Body Pattern:

Straight through; see Table 1 for inlet and outlet size.

Electrical Ratings:

System Transformer: 40 VA minimum NEMA rated.

NOTE: Larger system transformer may be required for specific applications.

Voltage and Frequency: 24 Vac, 60 Hz; 50 Hz models available.

Output Ratings:

- Igniter Load: 1.5A maximum.
- Induced Draft Motor Load: 2.5A Full Load, 10A. Locked Rotor at 120 Vac; 1.75A Full Load, 5A. Locked Rotor at 240 Vac.

24V Thermostat Current: 0.25A in run mode, with control connected directly to thermostat.

Prepurge Time (Factory-set):

15 seconds.

Trial for Ignition:

90 seconds.

Postpurge Time (Factory-set):

30 seconds. (Not available when SmartValve™ System Control is connected directly to thermostat.)

Retry Delay:

5 minutes.

Flame Failure Response Time:

1.6 seconds maximum at 2 µA.

Capacity:

See Table 1.

Conversion:

Use conversion factors in Table 2 to convert capacities for other gases.

Regulation Range:

See Table 1.

Natural-LP Gas Conversion Kits:

See Table 4.

Table 4. Natural-LP Gas Conversion Kits.

Model No. Suffix Letter	Kit to Convert Natural Gas to LP	Kit to Convert LP to Natural Gas
M	393691	394588
Q	396021	396025

Pipe Adapters:

Angle and straight adapters available for 3/8-, 1/2- and 3/4-in. pipe. See Table 5. Flange kits include one flange with attached O-ring, four mounting screws, a 9/64 in. hex wrench and instructions.

Approvals:

International Approval Services (IAS): Design Certified C2030025.

Table 5. Flange Adapter Part Numbers.

Inlet/Outlet Pipe Size (in. NPT)	Flange Type	Part No. ^{a,b}	
		Without Hex Wrench	With Hex Wrench
3/8	Straight	393690-1	393690-11
3/8	Elbow	393690-2	393690-12
1/2	Straight	393690-6	393690-16
1/2	Elbow	393690-3	393690-13
3/4	Straight	393690-4	393690-14
3/4	Elbow	393690-5	393690-15

^a Flange kits include one flange, one O-ring and four mounting screws.

^b Do not use flanges on control models with 3/4 in. inlet and 3/4 in. outlet. On models with 1/2 in. inlet and 3/4 in. outlet, use flanges only on the 1/2 in. inlet side.

PLANNING THE INSTALLATION

WARNING

Fire or Explosion Hazard.

Can cause property damage, severe injury, or death.

Follow these warnings exactly:

1. Plan the installation as outlined below.
2. Plan for frequent maintenance as described in the Maintenance section.

Heavy demands are made on the gas controls when intermittent pilot systems are used on central heating equipment in barns, greenhouses, and commercial properties and on heating appliances such as commercial cookers, agricultural equipment, industrial heating equipment and pool heaters.

Special procedures may be required to prevent nuisance shutdowns and control failure due to frequent cycling, severe environmental conditions related to moisture, corrosive chemicals, dust or excessive heat. These applications require Honeywell Home and Building Control Engineering review; contact your Honeywell Sales Representative for assistance.

Review the following conditions that can apply to your specific installation and follow the precautions suggested.

Frequent Cycling

This control is designed for use on appliances that typically cycle three to four times an hour only during the heating season. In year-around applications with greater cycling rates, the control can wear out more quickly. Perform a monthly check-out.

Water or Steam Cleaning

If a control gets wet, replace it. If the appliance is likely to be cleaned with water or steam, protect (cover) the control and wiring from water or steam flow. Mount the control high enough above the bottom of the cabinet so it does not get wet during normal cleaning procedures.

High Humidity or Dripping Water

Dripping water can cause the control to fail. Never install an appliance where water can drip on the control. In addition, high ambient humidity can cause the control to corrode and fail. If the appliance is in a humid atmosphere, make sure air circulation around the control is adequate to prevent condensation. Also, regularly check out the system.

Corrosive Chemicals

Corrosive chemicals can attack the control, eventually causing a failure. If chemicals are used for routine cleaning, avoid contact with the control. Where chemicals are suspended in air, as in some industrial or agricultural applications, protect the control with an enclosure.

Dust or Grease Accumulation

Heavy accumulations of dust or grease can cause the control to malfunction. Where dust or grease can be a problem, provide covers for the control to limit contamination.

Heat

Excessively high temperatures can damage the control. Make sure the maximum ambient temperature at the control does not exceed the rating of the control. If the appliance operates at very high temperatures, use insulation, shielding, and air circulation, as necessary, to protect the control. Proper insulation or shielding should be provided by the appliance manufacturer; verify proper air circulation is maintained when the appliance is installed.

INSTALLATION

When Installing this Product...

1. Read these instructions carefully. Failure to follow them could damage the product or cause a hazardous condition.
2. Check the ratings given in the instructions and on the product to make sure the product is suitable for your application.
3. Installer must be a trained, experienced service technician.
4. After installation is complete, check out product operation as provided in these instructions.

WARNING

Fire or Explosion Hazard.
Can cause property damage, severe injury or death.

Follow these warnings exactly:

1. Disconnect power supply before wiring to prevent electrical shock or equipment damage.
2. To avoid dangerous accumulation of fuel gas, turn off the gas supply at the appliance service valve before starting installation, and perform Gas Leak Test after installation is complete.
3. Do not bend pilot tubing at ignition system control or pilot burner after compression fitting is tightened, or gas leakage at the connection can result.
4. Always install a sediment trap in the gas supply line to prevent contamination of the ignition system control.



CAUTION

Electrical Shock or Equipment Damage Hazard. Can shock individuals or short equipment circuitry.

1. Disconnect power supply before installation.
2. Never apply a jumper across or short any of the terminals in the SV9541 or SV9641 wiring harness. This can damage the system transformer or the control.

Follow the appliance manufacturer instructions, if available; otherwise, use these instructions as a guide.

IMPORTANT

These ignition system controls are shipped with protective seals over the inlet and outlet tapings. Do not remove the seals until ready to install adapters or connect the piping.

Converting Ignition System Control from Natural Gas to LP Gas (or LP Gas to Natural Gas)



WARNING

Fire or Explosion Hazard.
Can cause property damage, severe injury, or death.

1. Do not attempt to convert step-opening models (suffix letter P).
2. Always change the main and pilot burner orifices when converting from natural to LP gas or from LP to natural gas. Carefully follow appliance manufacturer specifications and instructions to assure proper appliance conversion.
3. Ignition system controls are factory-set for natural (and manufactured) or LP gas. Do not attempt to use an ignition system control set for natural (manufactured) gas on LP gas, or an ignition system control set for LP gas on natural (manufactured) gas.

Ignition system controls with standard, slow-opening, and two-stage regulators (model numbers with suffix H, K, M, or Q) can be converted from one gas to the other with a conversion kit (ordered separately). See Table 4 to select the appropriate conversion kit.

Install Adapters To Control

If adapters are being installed on the control, mount them as follows:

Flanges

1. Choose the appropriate flange for your application.
2. Remove the seal over the ignition system control inlet or outlet.
3. Make sure that the O-ring is fitted in the groove of the flange. If the O-ring is not attached or is missing, do not use the flange.
4. With the O-ring facing the ignition system control, align the screw holes on the ignition system control with the holes in the flange. Insert and tighten the screws provided with the flange. See Fig. 1. Tighten the screws to 25 inch-pounds of torque to provide a gas-tight seal.

Bushings

1. Remove the seal over the ignition system control inlet or outlet.
2. Apply a moderate amount of good quality pipe compound to the bushing, leaving two end threads bare. On an LP installation, use compound that is resistant to LP gas. Do not use Teflon tape.
3. Insert the bushing in the ignition system control and carefully thread the pipe into the bushing until tight.

Complete the instructions below for installing the piping, installing the control, and connecting the pilot tubing and wiring. Make sure the leak test you perform on the control after completing the installation includes leak testing the adapters and screws. If you use a wrench on the valve after the flanges are installed, use the wrench only on the flange, not on the control. See Fig. 4.

Location

The ignition system controls are mounted in the appliance vestibule on the gas manifold.

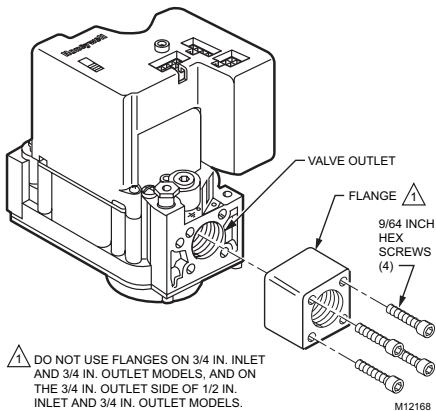

Fig. 1. Firmly fasten flange to valve, but do not overtighten screws.

Install Piping to Control

All piping must comply with local codes and ordinances or with the National Fuel Gas Code (ANSI Z223.1, NFPA No. 54), whichever applies. Tubing installation must comply with approved standards and practices.

1. Use new, properly reamed pipe that is free from chips. If tubing is used, make sure the ends are square, deburred and clean. All tubing bends must be smooth and without deformation.
2. Run pipe or tubing to the ignition system control. If tubing is used, obtain a tube-to-pipe coupling to connect the tubing to the ignition system control.

3. Install a sediment trap in the supply line to the ignition system control. See Fig. 2.

Install Control

1. Mount 0 to 90 degrees in any direction, including vertically, from the upright position of the ignition system control switch.
2. Mount so the gas flow is in the direction of the arrow on the bottom of the ignition system control.
3. Thread the pipe the amount shown in Table 6 for insertion into ignition system control or adapters. Do not thread pipe too far. Valve distortion or malfunction can result if the pipe is inserted too deeply.

Table 6. NPT Pipe Thread Length (in.).

Pipe Size	Thread Pipe This Amount	Maximum Depth Pipe can be Inserted into Control
3/8	9/16	3/8
1/2	3/4	1/2
3/4	13/16	3/4

4. Apply a moderate amount of good quality pipe compound (do not use Teflon tape) only to the pipe, leaving two end threads bare. On LP installations, use a compound resistant to LP gas. See Fig. 3.

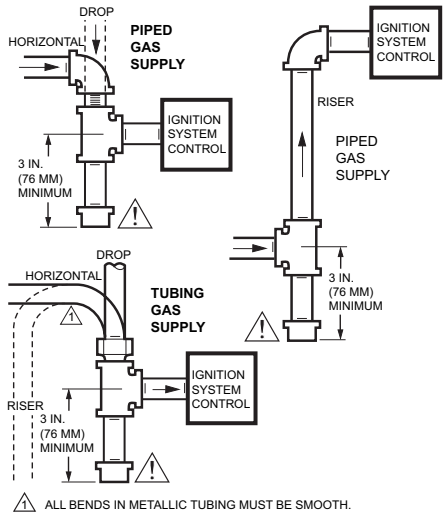

CAUTION
 GAS LEAKAGE HAZARD.
 FAILURE TO FOLLOW PRECAUTIONS CAN RESULT IN A GAS-FILLED WORK AREA. SHUT OFF THE MAIN GAS SUPPLY BEFORE REMOVING END CAP. TEST FOR GAS LEAKAGE WHEN INSTALLATION IS COMPLETE.

Fig. 2. Sediment trap installation.

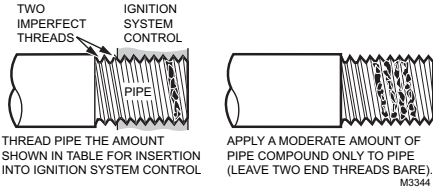

Fig. 3. Use moderate amount of pipe compound.

5. Remove the seals over the ignition system control inlet and outlet if necessary.
6. Connect the pipe to the ignition system control inlet and outlet. Use a wrench on the square ends of the ignition system control. If a flange is used, place the wrench on the flange rather than on the ignition system control. Refer to Fig. 4.

Connect Pilot Gas Tubing

1. Cut tubing to the desired length and bend as necessary for routing to the pilot burner. Do not make sharp bends or deform the tubing. Do not bend the tubing at the ignition system control after the compression nut is tightened because this can result in gas leakage at the connection.
2. Square off and remove burrs from the end of the tubing.

3. Unscrew the brass compression fitting from the pilot outlet (Fig. 5). Slip the fitting over the tubing and slide out of the way. See Fig. 6.
4. Push the tubing into the pilot gas tapping on the outlet end of the control until it bottoms. While holding the tubing all the way in, slide the fitting into place and engage the threads, then turn until finger tight. Tighten one more turn with a wrench, but do not overtighten.
5. Connect the other end of the tubing to the pilot burner according to the instructions supplied with the Q3450/Q3480.

NOTE: The pilot tubing provides the SmartValve™ System flame sense current path. Make sure the connections are clean and tight for proper operation.

WIRING

Follow the wiring instructions furnished by the appliance manufacturer, if available, or use the general instructions provided below. When these instructions differ from the appliance manufacturer, follow the appliance manufacturer instructions.

All wiring must comply with applicable electrical codes and ordinances.

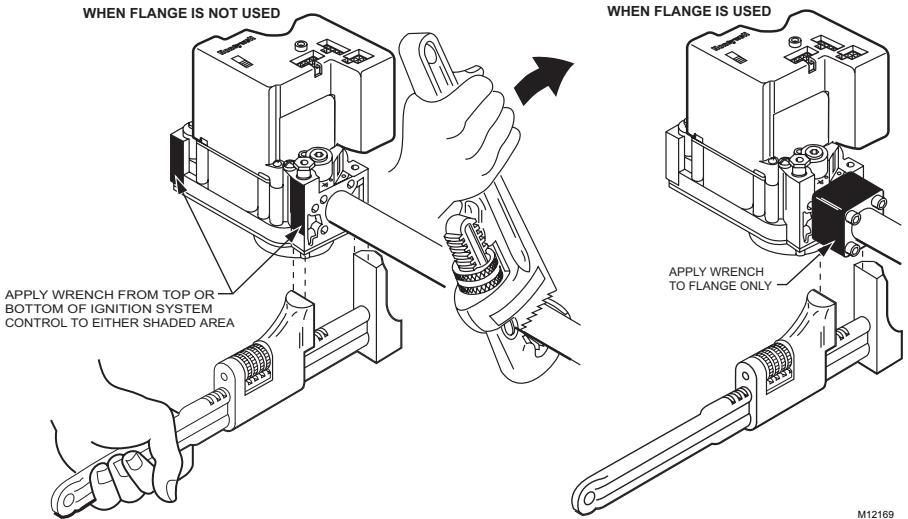

Fig. 4. Proper use of wrench on ignition system control with and without flanges.

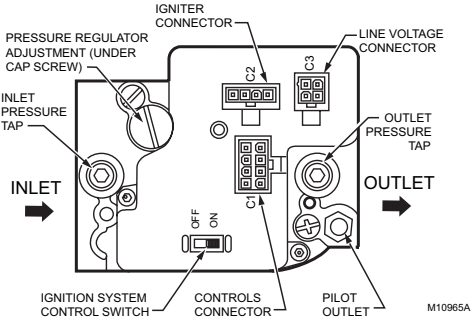
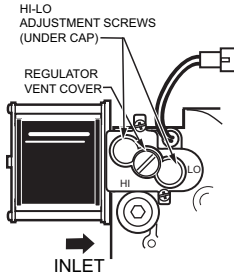

Fig. 5. Top view of ignition system control.

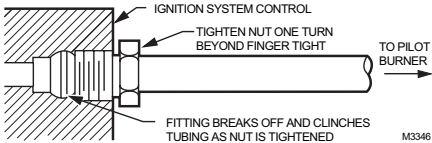

Fig. 6. Always use new compression fitting.

Disconnect power supply before making wiring connections to prevent electrical shock or equipment damage:

1. Check the power supply rating on the ignition system control and make sure it matches the available supply. The system transformer should be NEMA rated for 40 VA or larger. An appliance system power review is recommended. Install a transformer, thermostat and other controls, as required.
2. With 120 Vac power supply, connect the 120V hot lead to:
 - a. L1 on the ST9160 or 208907 Terminal Board
 - b. 120 Vac line on the ST9162.
 With 240 Vac power supply, there must not be more than 120 Vac potential between L1 or 120 LINE and the appliance chassis.
3. Verify that the appliance chassis has reliable connection to earth ground.
4. Connect control circuit to the ignition system control using the keyed connector. See Fig. 7 through 11.

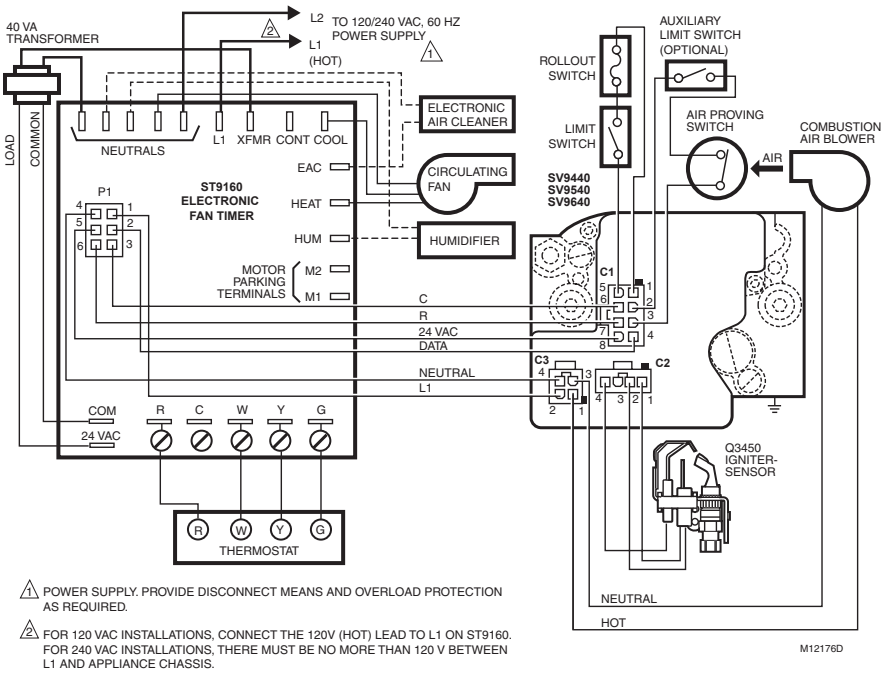

Fig. 7. Typical wiring connections in fan-assisted warm air furnace with ST9160 Electronic Fan Timer.

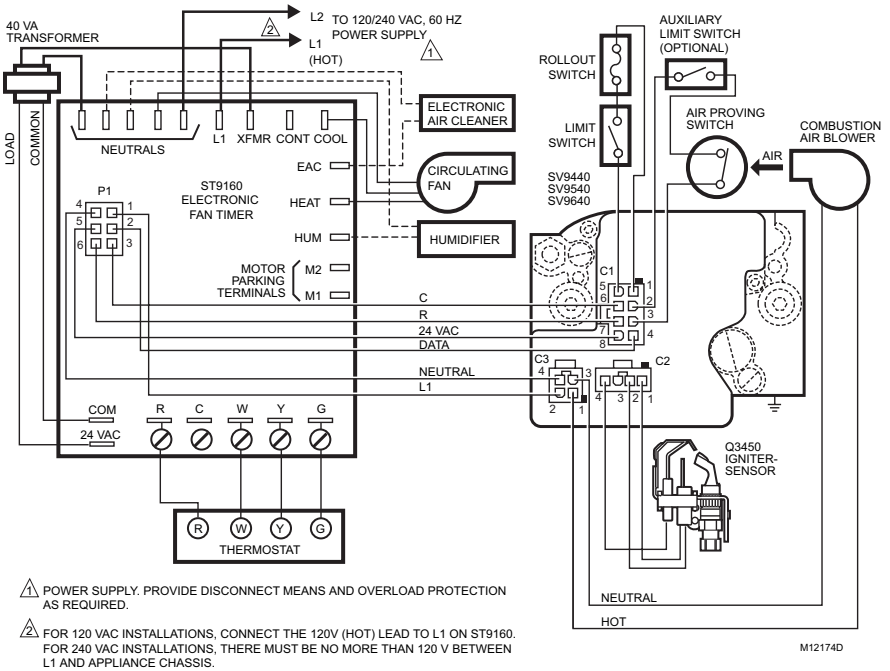

Fig. 8. Typical wiring connections with 208907 Terminal Board.

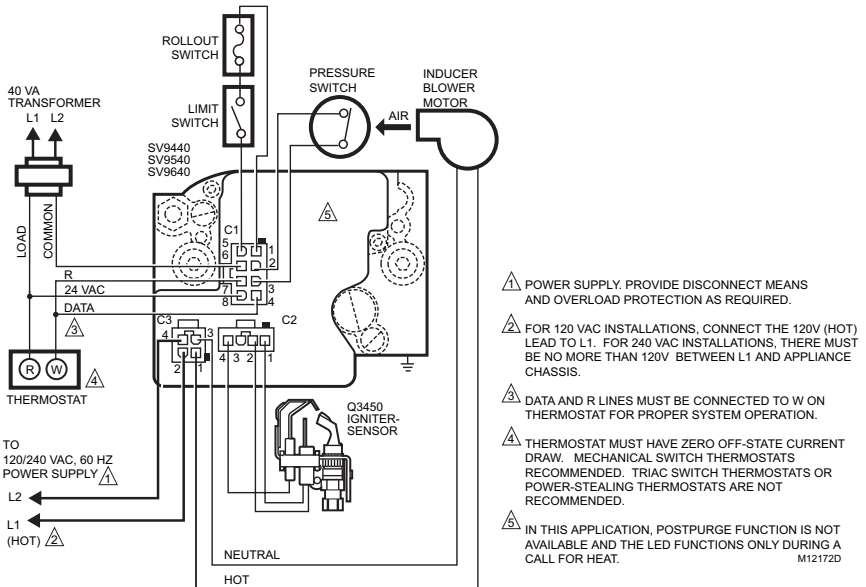

Fig. 9. Typical wiring connections direct to the thermostat.

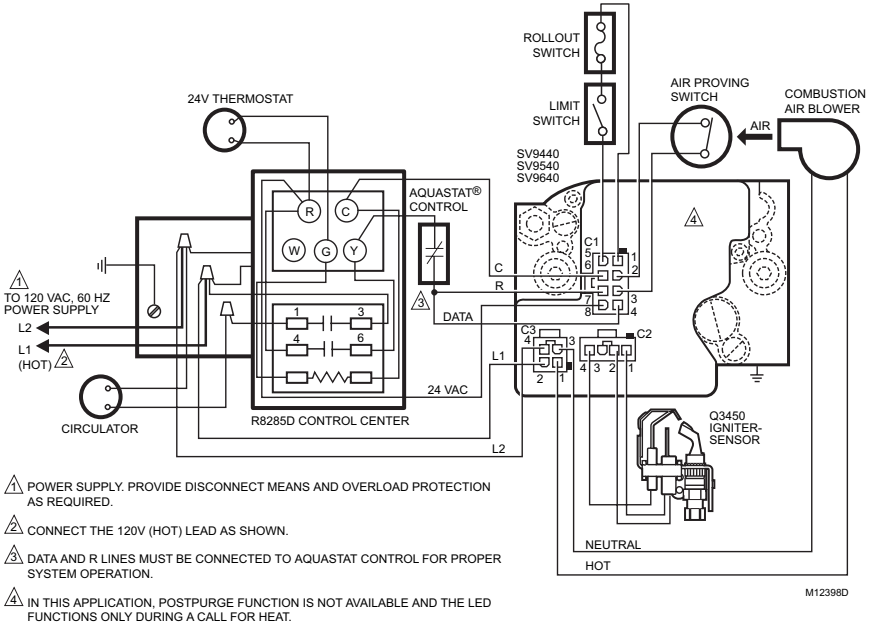

Fig. 10. Typical boiler wiring diagram.

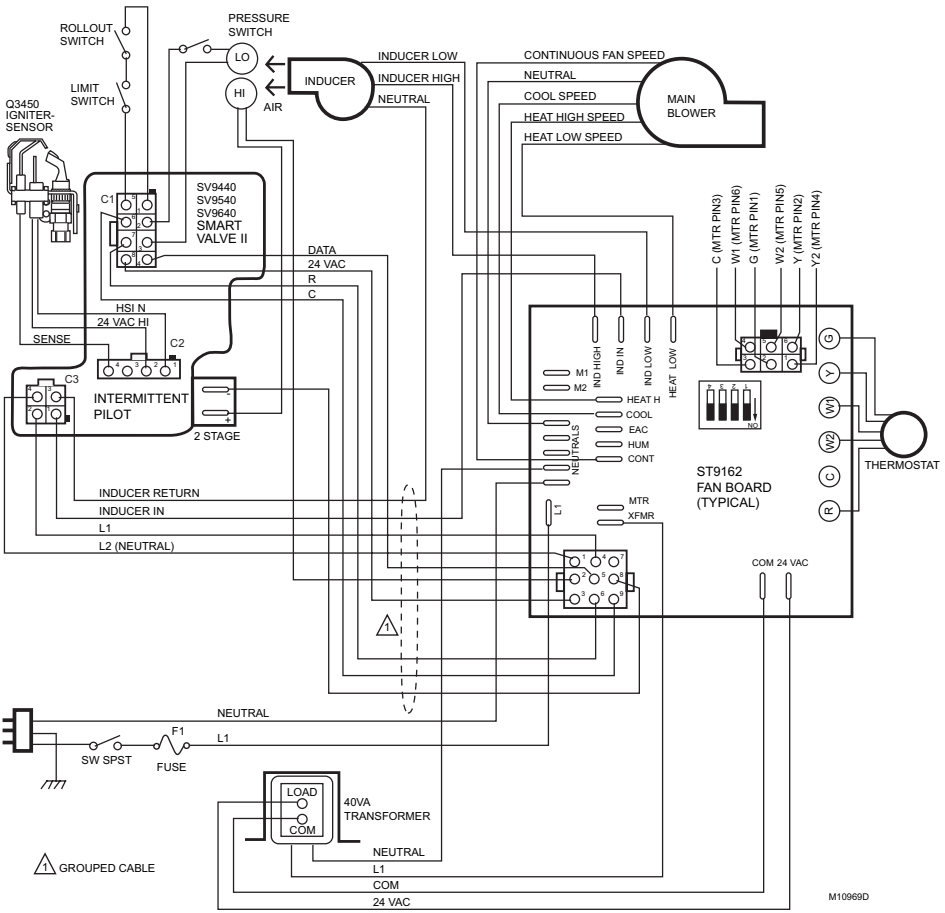

Fig. 11. Typical wiring connections for two-stage application with ST9162 Electronic Fan Timer.

STARTUP AND CHECKOUT

Ignition System Control Switch Settings

Ignition system control switch settings are as follows:

- OFF: Prevents pilot and main gas flow through the ignition system control.
- ON: Permits gas to flow through the control body. At the appropriate time in the appliance operation, main gas can flow to the main burner.

NOTE: Controls are shipped with the ignition system control switch in the ON position. If the appliance is operated with the ignition system control switch in the OFF position, the system will respond like the air proving switch is stuck in the no airflow position.

Turn on Main Burner

Follow the appliance manufacturer instructions or turn up the thermostat to call for heat.

Perform Gas Leak Test

⚠ WARNING

Fire or Explosion Hazard.
Can cause property damage, severe injury or death.
 Perform Gas Leak Test every time work is done on a gas system.

IMPORTANT

Do not spray soap and water solution on the SmartValve™ housing. Do not use an excessive amount of soap and water solution to perform the gas leak test. These can damage the control.

Gas Leak Test

1. Paint pipe connections upstream of the ignition system control with rich soap and water solution. Bubbles indicate a gas leak.
2. If a leak is detected, tighten the pipe connections.
3. Light the main burner. Stand clear of the main burner while lighting to prevent injury caused from hidden leaks that could cause flashback in the appliance vestibule.
4. With the main burner in operation, paint the pipe joints (including adapters) and the control inlet and outlet with rich soap and water solution.
5. If another leak is detected, tighten the adapter screws, joints, and pipe connections.
6. Replace the part if a leak cannot be stopped.

Check and Adjust Pilot Flame

The pilot flame should envelop 3/8 to 1/2 in. (10 to 13 mm) of the tip of the flame rod. It should also be in continual contact with the ground electrode. See Fig. 12. If the pilot flame is small or lazy, or does not touch the ground electrode, the inlet gas pressure may be too low, or the pilot orifice may be partially clogged. Check and repair as necessary. If the pilot flame is hard and noisy, the inlet gas pressure may be too high. The ignition system control has a pilot adjustment mechanism to reduce the pilot flow if necessary. If pilot adjustment is necessary, proceed as follows:

1. Remove pilot adjustment cover screw. See Fig. 5.
2. The pilot adjustment is shipped at the full pilot gas flow rate. Turn the inner adjustment screw clockwise if the inlet pressure is too high. Turn the inner adjustment screw clockwise to decrease or counter-clockwise to increase pilot flame.
3. Replace the cover screw after the adjustment to prevent gas leakage.

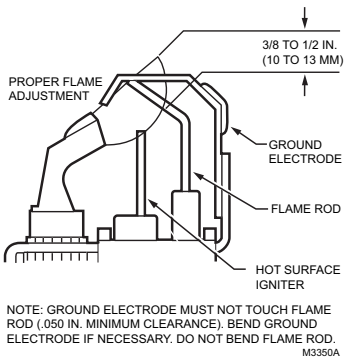

Fig. 12. Proper flame adjustment.

Check and Adjust Gas Input and Burner Ignition

IMPORTANT

1. Do not exceed input rating stamped on appliance nameplate, or manufacturer's recommended burner orifice pressure for size orifice(s) used. Be sure primary air supply to main burner is properly adjusted for complete combustion. Follow appliance manufacturer instructions.

2. IF CHECKING GAS INPUT BY CLOCKING GAS METER: Make certain there is no gas flow through the meter other than to the appliance being checked. Other appliances must remain off with the pilots extinguished (or deduct their consumption from the meter reading). Convert flow rate to Btuh as described in form 70-2602, Gas Controls Handbook, and compare to Btuh input rating on appliance nameplate.
3. IF CHECKING GAS INPUT WITH MANOMETER: Make sure the ignition system control is in the OFF position before removing outlet pressure tap plug to connect manometer (pressure gauge). Also move the ignition system control switch to the OFF position when removing the gauge and replacing the plug. Before removing inlet pressure tap plug, shut off gas supply at the manual valve in the gas piping to the appliance or, for LP, at the tank. Also shut off gas supply before disconnecting manometer and replacing plug. Repeat Gas Leak Test at plug with main burner operating.

NOTE: Check the inlet pressure before adjusting the pressure regulator.

Standard (M) Models

1. Carefully check the main burner lightoff. Make sure that the main burner lights smoothly and that all ports remain lit.
2. Check the full rate manifold pressure listed on the appliance nameplate. Ignition system control full rate outlet pressure should match this rating.
3. With main burner operating, check the ignition system control flow rate using the meter clocking method or check pressure using a manometer connected to the outlet pressure tap on the ignition system control. See Fig. 5.
4. If necessary, adjust the pressure regulator to match the appliance rating. See Table 7 and 8 for factory-set nominal outlet pressure and adjustment range.
 - a. Remove the pressure regulator adjustment cap screw.
 - b. Using a screwdriver, turn the inner adjustment screw (Fig. 5) clockwise to increase or counter-clockwise to decrease the gas pressure to the burner.
 - c. Always replace the cap screw and tighten firmly to prevent gas leakage.
5. If the desired outlet pressure or flow rate cannot be achieved by adjusting the ignition system control, check the ignition system control inlet pressure using a manometer at the inlet pressure tap of the ignition system control. If the inlet pressure is in the nominal range (see Table 7 and 8), replace the ignition system control. Otherwise, take the necessary steps to provide proper gas pressure to the control.

NOTE: If the burner firing rate is above 150,000 Btuh on SV9541 models (see Table 1 for SV9641 capacities), it may not be possible to deliver the desired outlet pressure. This is an application issue, not a control failure. Take whatever steps are required to correct the situation.

Two-Stage (Q) Models

Two-stage models allow independent adjustment of high and low pressure settings. The following sequence details adjusting the high pressure first and then adjusting the low pressure.

1. Set thermostat ten degrees above room temperature.
2. Carefully check the main burner lightoff. Make sure that the main burner lights smoothly and that all ports remain lit.
3. Check the full rate (high) manifold pressure listed on the appliance nameplate for high pressure. The ignition system control full rate outlet pressure should match this rating.
4. With main burner operating, check the ignition system control flow rate using the meter clocking method or check pressure using a manometer connected to the outlet pressure tap on the ignition system control. See Fig. 5.
5. If necessary, adjust the high pressure regulator to match the appliance rating. See Table 7 and 8 for factory-set nominal outlet pressure and adjustment range.
 - a. Remove the pressure regulator adjustment cap (Fig. 5).
 - b. Using a screwdriver, turn the inner adjustment screw for HI pressure clockwise to increase or counterclockwise to decrease the gas pressure to the burner.
6. After high pressure is checked, check low pressure regulation by removing the wire from terminal W2 of the ST9162 fan timer (to prevent ignition control from moving to high stage).
7. Check the low rate manifold pressure listed on the appliance nameplate. Ignition system control low rate outlet pressure should match this rating.
8. With main burner operating, check the ignition system control flow rate as before (using the meter clocking method or check pressure using a manometer connected to the outlet pressure tap on the ignition system control).
9. If necessary, adjust the low pressure regulator to match the appliance rating. See Table 7 and 8 for factory-set nominal outlet pressure and adjustment range.
 - a. Remove the pressure regulator adjustment cap (Fig. 5).
 - b. Using a screwdriver, turn the inner adjustment screw for LO pressure clockwise to increase or counterclockwise to decrease the gas pressure to the burner.
10. Once high and low pressure are checked and adjusted, replace pressure regulator adjustment cap. If the desired outlet pressure or flow rate cannot be achieved by adjusting the ignition system control, check the ignition system control inlet pressure using a manometer at the inlet pressure tap of the ignition system control. If the inlet pressure is in the nominal range (see Table 7 and 8), replace the ignition system control. Otherwise, take the necessary steps to provide proper gas pressure to the control.

Table 7. Pressure Regulator Specification Pressures (in. wc.).

Model Type	Type of Gas	Nominal Inlet Pressure Range	Factory Set Nominal Outlet Pressure		Setting Range	
			Step	Full Rate	Step	Full Rate
Standard	NAT	5.0 to 7.0	—	3.5	—	3.0 to 5.0
	LP	12.0 to 14.0	—	10.0	—	8.0 to 12.0
Two-stage	NAT	5.0 to 7.0	—	1.7 Low 3.5 High	—	0.9 to 3.0 Low 3.0 to 5.0 High
	LP	121.0 to 14.0	—	4.9 Low 10.0 High	—	3.5 to 5.5 Low 8.0 to 11.0 High

Table 8. Pressure Regulator Specification Pressures (kPa).

Model Type	Type of Gas	Nominal Inlet Pressure Range	Factory Set Nominal Outlet Pressure		Setting Range	
			Step	Full Rate	Step	Full Rate
Standard	NAT	1.2 to 1.7	—	0.9	—	0.7 to 1.2
	LP	2.9 to 3.9	—	2.5	—	2.0 to 3.0
Two-Stage	NAT	1.2 to 1.7	—	0.48 Low 0.9 High	—	0.37 to 0.75 Low 0.75 to 1.2 High
	LP	2.9 to 3.9	—	1.2 Low 2.5 High	—	0.9 to 1.4 Low 2.0 to 2.5 High

MAINTENANCE

WARNING

Fire or Explosion Hazard.

Can cause property damage, severe injury or death.

Do not disassemble the ignition control: it contains no replaceable components. Attempted disassembly, repair, or cleaning can damage the control, resulting in gas leakage.

Regular preventive maintenance is important for applications in the commercial cooking and agricultural and industrial industries that place a heavy load on system controls because:

- In many such applications, particularly commercial cooking, the equipment operates 100,000 to 200,000 cycles per year. Such heavy cycling can wear out the gas control in one to two years.
- Exposure to water, dirt, chemicals and heat can damage the gas control and shut down the control system.

The maintenance program should include regular checkout of the control as outlined in the Startup and Checkout section, and the control system as described in the appliance manufacturer literature.

Maintenance frequency must be determined individually for each application. Some considerations are:

- Cycling frequency. Appliances that may cycle 20,000 times annually should be checked monthly.
- Intermittent use. Appliances that are used seasonally should be checked before shutdown and again before the next use.
- Consequence of unexpected shutdown. Where the cost of an unexpected shutdown would be high, the system should be checked more often.
- Dusty, wet, or corrosive environments. Since these environments can cause the gas control to deteriorate more rapidly, the system should be checked more often.

The system should be replaced if:

- It does not perform properly on checkout or troubleshooting.
- The gas control is likely to have operated for more than 200,000 cycles.
- The control is wet or looks as if it has been wet.

SERVICE

WARNING

Fire or Explosion Hazard.

Can cause property damage, severe injury or death.

Do not disassemble the ignition control: it contains no replaceable components. Attempted disassembly, repair, or cleaning can damage the control, resulting in gas leakage.

CAUTION

Electrical Shock or Equipment Damage Hazard. Can shock individuals or short equipment circuitry.

1. Disconnect power supply before installation.
2. Never apply a jumper across or short any of the terminals in the SV9541 or SV9641 wiring harness. This can damage the system transformer or the control.

After servicing, verify proper system operation.

IMPORTANT

Allow 60 seconds after shutdown before re-energizing step-opening model to assure lightoff at step pressure.

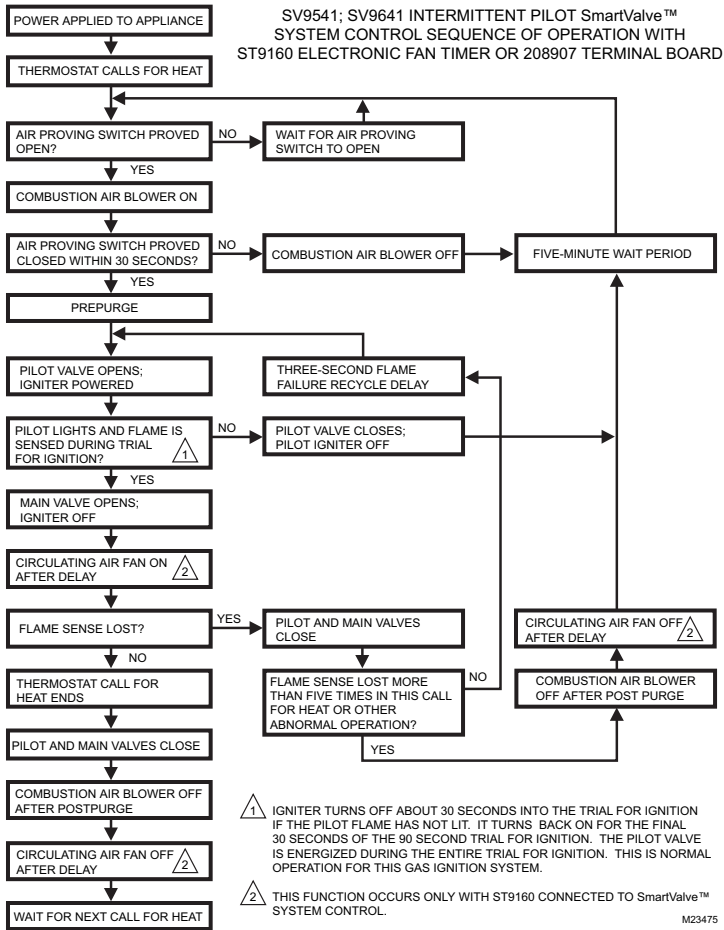

Fig. 13. Sequence of operation for ignition controls with ST9160 fan timer or 208907 terminal board.

Sequence of Operation

1. Make sure the ignition system control switch is in the ON position.
2. Follow the sequence of operation as shown in Fig. 13 for ignition controls using an ST9160 Fan Timer or 208907 Terminal Board; see Fig. 14 for two-stage ignition controls with an ST9162 fan timer.

SV9541; SV9641 INTERMITTENT PILOT SmartValve™
SYSTEM CONTROL SEQUENCE OF OPERATION
WITH ST9162A 2-STAGE ELECTRONIC FAN TIMER

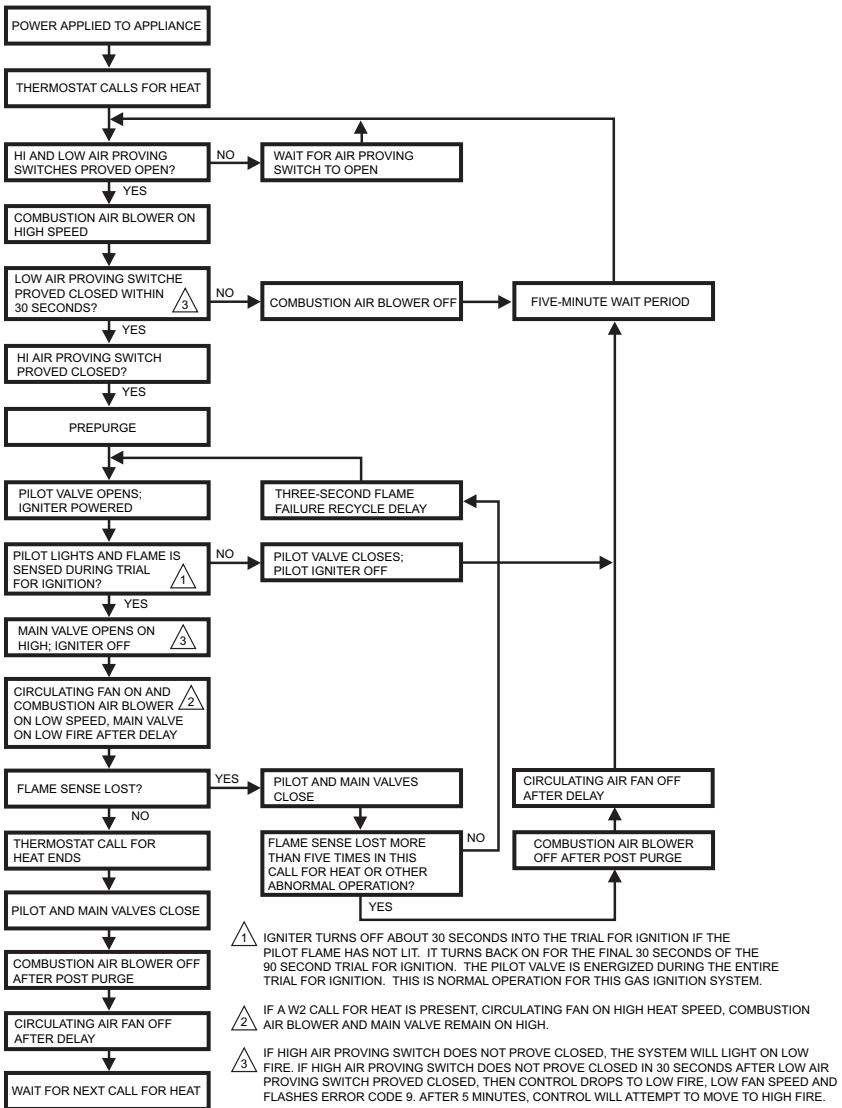

Fig. 14. Sequence of operation for two-stage ignition controls with ST9162 fan timer.

TROUBLESHOOTING

Troubleshooting with LED Indicator Assistance

There is no cycling of appliance power and no thermostat call for heat because an appliance failure has occurred.



CAUTION

Electrical Shock or Equipment Damage Hazard. Can shock individuals or short equipment circuitry.

Only a trained, experienced service technician should perform this troubleshooting.

1. Check the system thermostat to make sure it is calling for heat. (Do not cycle the thermostat on and off at this time.)
2. Remove the appliance burner compartment door. Do not interrupt power to the SV9541 or SV9641 by opening any electrically interlocked panels.
3. Observe the LED indicator on the SV9541 or SV9641; check and repair system as noted in Table 9 or 10.

Table 9. Troubleshooting with LED indicator assistance for ignition controls using ST9160 Fan Timer or 208907 Terminal Board.

LED Status	Indicates	Check/Repair
OFF	No power to system control	<ol style="list-style-type: none"> 1. Line voltage input power at L1 and L2 connectors on ST9160 Electronic Fan Timer (EFT) or 208907 Terminal Board. 2. Low voltage (24V) power at 24 VAC and COM terminals on ST9160 or Terminal Board. 3. Fuse on ST9160 EFT if provided. 4. System wiring harness is in good condition and securely connected at both ends.
Bright-Dim	Normal Operation This indication shows whenever the system is powered, unless some abnormal event has occurred.	Not Applicable
2 Flashes	Airflow proving switch remains closed longer than 30 second after a call for heat begins. Combustion air blower is not energized until airflow proving switch opens.	<ol style="list-style-type: none"> 1. Airflow proving switch stuck closed. 2. Airflow proving switch miswired or jumpered.
3 Flashes	Airflow proving switch remains open longer than 30 seconds after combustion air blower energized. System goes into 5 minute delay period, with combustion air blower off. At the end of the 5 minute delay, another ignition cycle will begin.	<ol style="list-style-type: none"> 1. Ignition system control switch must be in the ON position. 2. Airflow proving switch operation, tubing, and wiring. 3. Obstructions or restrictions in appliance air intake or exhaust flue system that prevent proper combustion airflow.
4 Flashes	Limit string is open. Combustion air blower is energized. If control system includes ST9160 Electronic Fan Timer, the heat speed circulating air fan will be energized until the limit string resets.	<ol style="list-style-type: none"> 1. Open manual reset or auto reset burner rollout switch. 2. Open high temperature or auxiliary limit switch. 3. Limit and rollout switch wiring is in good condition and securely connected.
5 Flashes	Flame signal sensed out of proper sequence. Combustion air blower is energized. If control system includes ST9160 Electronic Fan Timer, the heat speed circulating air fan will be energized after the selected heat fan on delay.	Flame at pilot burner.
6 Flashes	System Lockout After 5-minute delay time, control system resets and initiates a new ignition sequence if the call for heat is still present.	<ol style="list-style-type: none"> 1. Gas supply off or at too low pressure to operate. 2. Damaged or broken HSI element. 3. Flame sense rod contaminated or in incorrect location. 4. Pilot burner located in incorrect position. 5. Pilot burner leadwires are in good condition and properly connected.

Table 10. Troubleshooting with LED indicator assistance for ignition controls using ST9160 Fan Timer or 208907 Terminal Board

LED Status	Indicates	Check/Repair
OFF	No power to system control.	<ol style="list-style-type: none"> 1. Line voltage input power at 120 VAC LINE and L2 connectors on ST9162 Electric Fan Timer (EFT). 2. Low voltage (24V) power at 24 VAC and COM terminals on ST9162. 3. System wiring harness is in good condition and securely connected at both ends.
Bright-Dim	Normal Operation. This indication shows whenever the system is powered, unless some abnormal event has occurred.	Not Applicable.
2 Flashes	Airflow proving switch remains closed longer than 30 second after a call for heat begins. Combustion air blower is not energized until low airflow proving switch opens.	<ol style="list-style-type: none"> 1. Low airflow proving switch stuck closed. 2. Low airflow proving switch miswired or jumpered.
3 Flashes	Control switch in OFF position or low airflow proving switch remains open longer than 30 seconds after combustion air blower energized. System goes into 5 minute delay period, with combustion air blower off. At the end of the 5 minute delay, another ignition cycle will begin.	<ol style="list-style-type: none"> 1. Ignition system control switch must be in the ON position. 2. Low airflow proving switch operation, tubing, and wiring. 3. Obstructions or restrictions in appliance air intake or exhaust flue system that prevent proper combustion air flow.
4 Flashes	Limit string is open. Combustion air blower is energized. The heat speed circulating blower is energized after the heat on fan delay.	<ol style="list-style-type: none"> 1. Open manual reset or auto reset burner rollout switch. 2. Open high temperature or auxiliary limit switch. 3. Limit and rollout switch wiring is in good condition and securely connected.
5 Flashes	Flame signal sensed out of proper sequence. Combustion air blower is energized. The heat speed circulating blower is energized after the heat on fan delay.	Flame at pilot burner.
6 Flashes	System Lockout. After 5-minute delay time, control system resets and initiates a new ignition sequence if the call for heat is still present.	<ol style="list-style-type: none"> 1. Gas supply off or pressure too low or high for appliance to operate. 2. Damaged or broken HSI element. 3. Line voltage HOT leadwire not connected to 120 VAC LINE terminal on ST9162. 4. Appliance not properly earth grounded. 5. Flame sense rod contaminated or in incorrect location. 6. Pilot burner located in incorrect position. 7. Pilot burner leadwires are in good condition and properly connected.
8 Flashes	High airflow proving switch remains closed longer than 30 seconds after a call for heat begins. ^a or Low airflow proving switch opens in Run Mode. ^b	<ol style="list-style-type: none"> 1. High airflow proving switch stuck closed. 2. High airflow proving switch miswired or jumpered. 3. Obstructions or restrictions in appliance air intake or exhaust flue system that prevent proper combustion airflow.
9 Flashes	High airflow proving switch remains open longer than 30 seconds after combustion air blower is energized. System operates at low fire only during a 5-minute delay period. After the delay period, another 30-second attempt for high fire/high inducer speed occurs.	<ol style="list-style-type: none"> 1. Second stage solenoid coil must be properly connected. 2. High airflow proving switch miswired or jumpered. 3. Obstructions or restrictions in appliance air intake or exhaust flue system that prevent proper combustion airflow.

^a Combustion air blower is not energized until high airflow proving switch opens.^b Control will not operate on high combustion air blower speed for two minutes after the low airflow proving switch opens in run mode.

4. After LED flash code analysis and appliance repair are complete, turn the thermostat below room temperature for 10 seconds; turn the thermostat above room temperature to initiate a new call for heat.
5. Observe the ignition sequence, comparing it to the Sequence of Operation shown in Fig. 13 or 14. Allow the new ignition sequence to proceed until appliance lights or an abnormal or unexpected event is observed.

1. Make sure the appliance power is on and any manually operated gas cock on the appliance is open.
2. Remove appliance burner compartment door. Confirm that the SV9541, SV9641 LED indicator is flashing in a bright-dim sequence.
3. Make sure the ignition system control switch is in the ON position.
4. Disconnect the system thermostat leadwires at the ST9160 EFT or the 208907 Terminal Board.
5. Using alligator clips on a short jumper wire, jumper the R and W terminals on the ST9160 EFT or terminal board.
6. Observe the appliance operation, comparing it to the Sequence of Operation shown in Fig. 13. Allow the ignition sequence to proceed until the appliance lights or an abnormal or unexpected event is observed.
7. Check the appliance as shown in Table 11.

Troubleshooting Without LED Indicator Assistance (ST9160 Only)

Appliance power or thermostat call for heat has cycled since appliance failure occurred.



CAUTION

Electrical Shock or Equipment Damage Hazard. Can shock individuals or short equipment circuitry.

Only a trained, experienced service technician should perform this troubleshooting.

Table 11. Troubleshooting without LED indicator assistance for ignition controls using an ST9160 Fan Timer or 208907 Terminal Board.

If	And	Check/Repair
Combustion air blower does not energize.	2 flash code does not come on 30 seconds after call for heat starts.	<ol style="list-style-type: none"> 1. Combustion air blower wiring. 2. Combustion air blower. 3. Wiring between ST9160 and SV9541.
Combustion air blower does not energize.	2 flash code does come on 30 seconds after call for heat starts.	<ol style="list-style-type: none"> 1. Airflow proving switch stuck closed. 2. Airflow proving switch miswired or jumpered.
Combustion air blower is energized.	3 flash code does not come on after 30 seconds.	Wait for the prepurge time to expire.
3 flash code comes on 30 seconds after combustion air blower is energized.	Combustion air blower turns off.	<ol style="list-style-type: none"> 1. Ignition system control switch must be in the ON position. 2. Airflow proving switch stuck in open position. 3. Airflow proving switch tubing and wiring. 4. Obstructions or restrictions in appliance air intake or exhaust flue system that prevent proper combustion air flow.
Prepurge time has expired.	HSI element does not glow red within 5 seconds.	<ol style="list-style-type: none"> 1. Broken or damaged HSI element. 2. Broken or damaged HSI element leadwires. 3. SV9541 or SV9641 failure to power HSI element.
HSI element is glowing red.	Pilot does not light during the 90-second trial for ignition. NOTE: HSI element turns off for approximately 25 seconds during the 90-second trial for ignition.	<ol style="list-style-type: none"> 1. Pilot tubing not purged of air. (Initiate another ignition sequence with the R-W jumper to clear pilot tubing more quickly.) 2. Inlet gas pressure too low for proper appliance operation. 3. Pilot burner improperly positioned in air-flow. 4. Clogged or incorrect pilot orifice. 5. Combustion air blower moving pilot gas away from HSI element.

Table 11. Troubleshooting without LED indicator assistance for ignition controls using an ST9160 Fan Timer or 208907 Terminal Board. (Continued)

If	And	Check/Repair
Pilot lights during trial for ignition.	Main gas does not flow. If pilot flame is not sensed during trial for ignition, main valve does not open. System shuts off HSI element and pilot gas flow, goes through a 5 minute delay period, then initiates another ignition trial.	<ol style="list-style-type: none"> 1. Line voltage to L1 terminal of ST9160 or terminal board must be 120 volts with reference to appliance chassis. 2. Appliance must be reliably connected to earth ground. 3. Combustion air blower moving pilot flame away from pilot burner flame rod. 4. Inlet gas pressure too low for proper flame sensing. 5. Flame sense rod contaminated or in incorrect location. 6. Wiring between SV9541 or SV9641 and pilot burner must be in good condition and properly connected.
Main burner lights.	Circulating air fan is not turned on after appropriate delay time (only systems with ST9160 Electronic Fan Timer).	<ol style="list-style-type: none"> 1. Wiring between SV9541 or SV9641 and ST9160 EFT. 2. Proper operation of ST9160 EFT.
Main burner goes out before thermostat call for heat ends.	4 flash code comes on.	<ol style="list-style-type: none"> 1. Open manual reset or auto reset burner rollout switch. 2. Open high temperature or auxiliary limit switch. 3. Limit and rollout switch string wiring is in good condition and securely connected.
Main burner goes out before thermostat call for heat ends.	4 flash code does not come on.	<ol style="list-style-type: none"> 1. Intermittent wiring connection between SV9541 or SV9641 and pilot burner. 2. Combustion air blower moving pilot flame away from pilot burner flame rod. 3. Airflow proving switch has opened. 4. Flame sense rod ceramic or leadwire overheated. 5. Gas flow supply reduced or interrupted.
5 flash code comes on.	—	Flame at pilot burner.
6 flash code comes on. After 5 minute delay time, control system resets and initiates a new ignition sequence if the call for heat is still present.	—	<ol style="list-style-type: none"> 1. Gas supply off or at too low pressure to operate appliance. 2. Damaged or broken HSI element. 3. Flame sense rod contaminated or in incorrect location. 4. Pilot burner located in incorrect position. 5. Pilot burner leadwires in good condition and properly connected.

Table 12. Replacement Chart for SV9570.

Part Number		Specifications						Cross
Ignition/ Application	Universal Service Part	Gas Type	Opening Characteristics	Ambient Temperature Range	Includes			Replaces
					Natural to LP Conversion Kit	3/4 in. x 1/2 in. Reducer Bushings	Extension Harness	
Intermittent HSI Pilot with Combustion Air Control and Limit Monitoring	SV9541Q2561	Natural	Two-stage	-40°F to 175°F (-40°C to 79°C)	Yes	None	No	SV9540Q2464 SV9541Q3098
	SV9641M4510	Natural	Standard Opening		Yes	Two		SV9541M2094 SV9540M2229 SV9540M2260 SV9640M4116 SV9640M4124 SV9540M2278 SV9540M2245 SV9640M3126 SV9640M4132

INSTRUCTIONS TO THE HOMEOWNER

WARNING

Fire or Explosion Hazard.
Can cause property damage, severe injury, or death.

Follow these warnings exactly:

1. Pilot flame is lit automatically. Do not light the pilot flame manually.
2. Before lighting the pilot burner flame, smell around the appliance for gas. Be sure to smell next to the floor because LP gas is heavier than air. If you smell gas:
 - Turn off the gas supply at the appliance service valve. On LP gas systems, turn off the gas supply at the gas tank.
 - Do not light any appliances in the house.
 - Do not touch electrical switches or use the phone.
 - Leave the building and use a neighbor's phone to call your gas supplier.
 - If you cannot reach your gas supplier, call the fire department.
3. Replace the ignition system control in the event of any physical damage, tampering, bent terminals, missing or broken parts, stripped threads, or evidence of exposure to heat.

IMPORTANT

Follow the operating instructions provided by the manufacturer of your heating appliance. The information below describes a typical ignition system control application, but the specific controls used and the procedures outlined in your appliance manufacturer's instructions can differ, requiring special instructions.

STOP: Read the Warnings Above Before Proceeding

The pilot flame is lit automatically. If the appliance does not turn on when the thermostat is set several degrees above room temperature, follow these instructions:

1. Set the thermostat to its lowest setting to reset the safety control.
2. Disconnect all electric power to the appliance.
3. Remove the ignition system control access panel.
4. Move the ignition system control switch to the OFF position.
5. Wait five minutes to clear out any unburned gas. Then if you smell gas, STOP! Follow Step 2 in the Warning above. If you do not smell gas, continue with the next step.
6. Move the ignition system control switch to the ON position.
7. Replace the ignition system control access panel.
8. Reconnect all electric power to the appliance.
9. Set the thermostat to the desired setting.
10. If the appliance does not turn on, move the ignition system control switch to the OFF position and contact a qualified service technician for assistance.

Turning off the Appliance

Vacation Shutdown

Set the thermostat to the desired room temperature while you are away.

Complete Shutdown

Turn off power to the appliance. Turn off the gas supply to the appliance. The appliance will completely shut off. Follow the procedure in the Instructions to the Homeowner section above to resume normal operation.

Automation and Control Solutions

Honeywell International Inc.
1985 Douglas Drive North
Golden Valley, MN 55422
customer.honeywell.com

Honeywell Limited-Honeywell Limitée
35 Dynamic Drive
Toronto, Ontario M1V 4Z9

