

FAN COILS



Use of the AHRI Certified TM Mark indicates a manufacturer's participation in the program. For verification of certification for individual products, go to www.ahrirectory.org.



Model Number	Tons	Nom. CFM (L/s)	Dimensions H x W x D in. (mm)	Filter Size in. (mm)	Ship Wt lbs. (kg)
WAP*184A	1-1/2	600 (283)	42-11/16 x 14-5/16 x 22-1/16 (1084 x 364 x 560)	13 x 21-1/2 (330 x 546)	112 (51)
WAP*244A	2	800 (378)	42-11/16 x 14-5/16 x 22-1/16 (1084 x 364 x 560)	13 x 21-1/2 (330 x 546)	112 (51)
WAP*304A	2-1/2	1000 (472)	49-5/8 x 17-5/8 x 22-1/16 (1261 x 448 x 560)	16-3/8 x 21-1/2 (416 x 546)	122 (55)
WAP*364A	3	1200 (566)	49-5/8 x 17-5/8 x 22-1/16 (1261 x 448 x 560)	16-3/8 x 21-1/2 (416 x 546)	122 (55)
WAP*424A	3-1/2	1400 (661)	49-5/8 x 21-1/8 x 22-1/16 (1261 x 537 x 560)	19-7/8 x 21-1/2 (505 x 546)	157 (71)
WAP*484A	4	1600 (755)	49-5/8 x 21-1/8 x 22-1/16 (1261 x 537 x 560)	19-7/8 x 21-1/2 (505 x 546)	157 (71)

* L = Aluminum Tube, Aluminum Fin Evaporator Coil
 M = Copper Tube, Aluminum Fin Evaporator Coil
 T = Tin Coated Copper Tube, Aluminum Fin Evaporator Coil

WAP*604A	5	1750 (825)	53-7/16 x 21-1/8 x 22-1/16 (1357 x 537 x 560)	19-7/8 x 21-1/2 (505 x 546)	175 (79)
----------	---	------------	--	--------------------------------	----------

* M = Copper Tube, Aluminum Fin Evaporator Coil
 T = Tin Coated Copper Tube, Aluminum Fin Evaporator Coil

ALL MODELS

- 1-1/2 thru 5 tons
- Available for environmentally sound R-410A systems
- Factory installed piston metering device with Teflon ring on 1.5 – 4 ton sizes, TXV on 5 ton size
- Sweat connections
- Primary and secondary drain fittings
- Multiple electrical entry locations
- Time delay relay (TDR)
- Field installed heater packages from 5 kW – 30 kW available separately
- HUD approved for manufactured housing
- 208/230-1-60 supply voltage
- Units tested and certified by manufacturer to achieve a 2% or less leakage rate at 1.0 inch water column
- 1 inch thick insulation with R value of 4.2
- Filter (washable) available as accessory
- ECM 5-speed motor
- Multiposition installation – upflow or horizontal left standard, horizontal right with minor modification (field convertible to downflow with available accessory kit)
- Low voltage circuit protective fuse (3 amp) inline on wire harness
- No Heat (Plug) Kit factory installed

LIMITED WARRANTY*

- 5 year parts limited warranty
 - With timely registration, an additional 5 year parts limited warranty

* For owner occupied, residential applications only. See warranty certificate for complete details and restrictions, including warranty coverage for other applications.

WAPL, WAPM, WAPT

Product Specifications

FAN COIL MODEL NUMBER IDENTIFICATION GUIDE							
Digit Position:	1, 2	3	4	5, 6	7	8	9
Example Part Number:	WA	P	M	24	4	A	1
WA = Air Handler							
P = High Efficiency ECM Motor		MOTOR TYPE					
L = Aluminum Tube, Aluminum Fin Evaporator Coil							
M = Copper Tube, Aluminum Fin Evaporator Coil							
T = Tin Coated Copper Tube, Aluminum Fin Evaporator Coil		INSTALLATION TYPE					
18 = 18,000 BTU/hr = 1-1/2 TONS							
24 = 24,000 BTU/hr = 2 TONS							
30 = 30,000 BTU/hr = 2-1/2 TONS							
36 = 36,000 BTU/hr = 3 TONS							
42 = 42,000 BTU/hr = 3-1/2 TONS							
48 = 48,000 BTU/hr = 4 TONS							
60 = 60,000 BTU/hr = 5 TONS		NOMINAL COOLING CAPACITY					
4 = R-410A						REFRIGERANT	
SALES DIGIT							
EXTRA DIGIT							

ACCESSORIES PART NUMBER IDENTIFICATION GUIDE					
	EB	AC	01	NCB	A
EB = Evaporator Blower					
AC = Accessory					
01 = Product Identifier Number					
NCB = Non-Combustible Base Kit					
DFK = Down Flow Kit					
PLG = Power Plug (no heat kit)					
SPK = Single Point Wiring Kit					
FKS = Filter Kit Small					
FKM = Filter Kit Medium					
FKL = Filter Kit Large					
FKX = Filter Kit Extra Large					
CTK = Condensate Trap Kit (PVC pipe)					
Sales Code					

ELECTRIC HEATER MODEL NUMBER IDENTIFICATION GUIDE						
	EHK	05	A	K	N	1
EHK = Electric Heater Kit						
05 = 5 kW						
07 = 7 kW						
09 = 9 kW						
10 = 10 kW						
15 = 15 kW						
18 = 18 kW						
20 = 20 kW						
25 = 25 kW						
30 = 30 kW						
		NOMINAL HEAT VALUE				
Sales Code						
K = 208 / 230 single-phase						
H = 208 / 230, 3-phase						
KC = 208 / 230, supplied as single phase, field convertible to 3-phase						
HC = 208 / 230 supplied as 3-phase, field convertible to single phase						
						VOLTAGE (60 Hz)
Product Identifier						
Engineering Code						

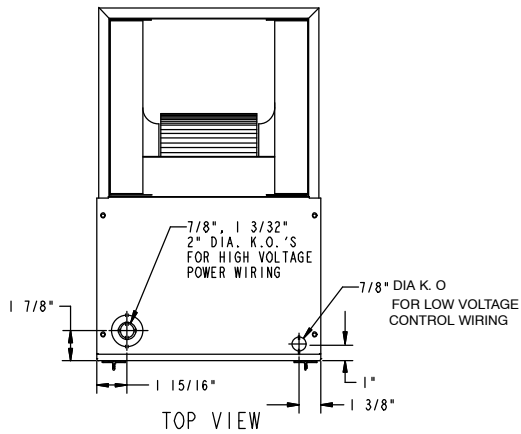

NOTE:

- SERIES DESIGNATION IS THE 9TH POSITION OF UNIT PRODUCT NUMBER
- ALL DIMENSIONS ARE IN "INCHES" UNLESS NOTED.

NOTE: ALLOW 21" FROM FRONT FOR SERVICE

UNIT CONNECTION SIZES	
SUCTION: 018 & 024	- 5/8" I.D. SWEAT
030 & 036	- 3/4" I.D. SWEAT
042 THRU 060	- 7/8" I.D. SWEAT
LIQUID:	3/8" I.D. SWEAT
CONDENSATE:	3/4" FPT

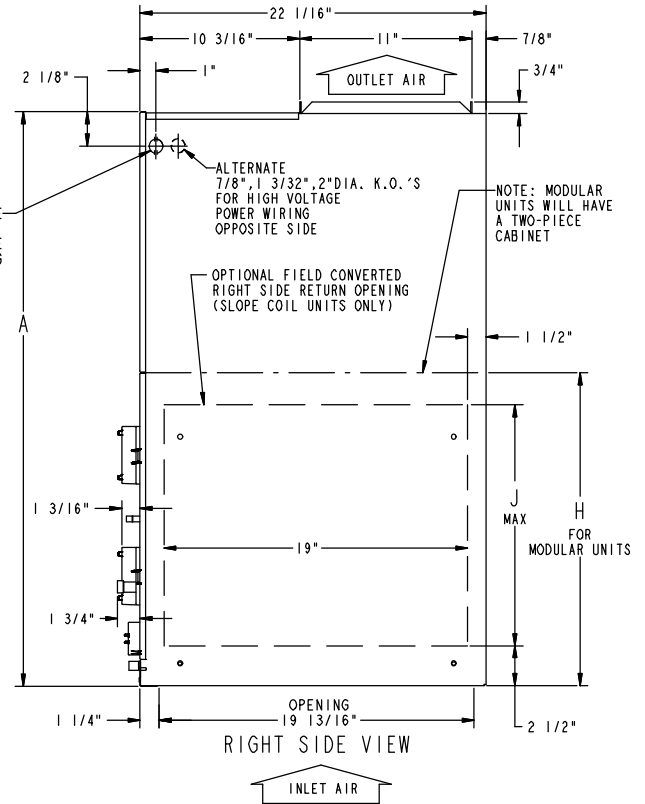
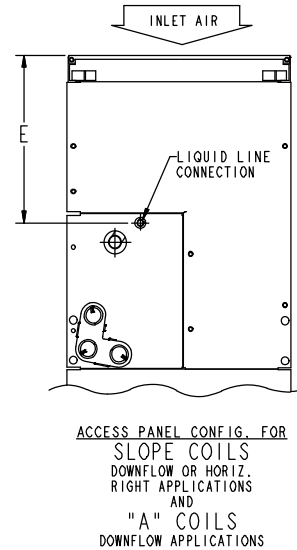
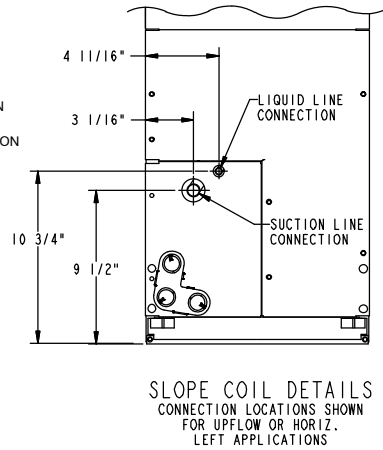
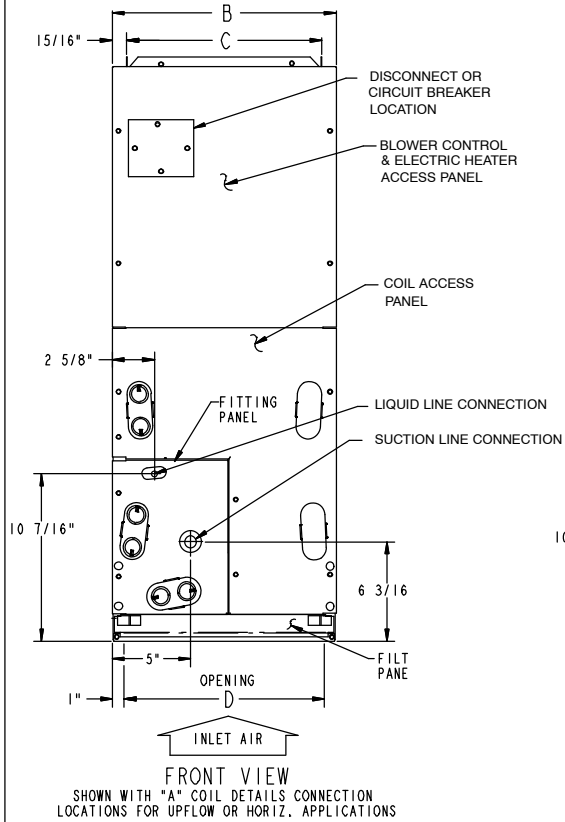

SD5115-4 Rev. A

Dimension English (Inches)

SLOPE COIL

- NOTES:
 1. CONDENSATE PAN DRAIN CAPS NOT SHOWN FOR CLARITY.
 2. ALL DIMENSIONS ARE IN "INCHES" UNLESS NOTED.

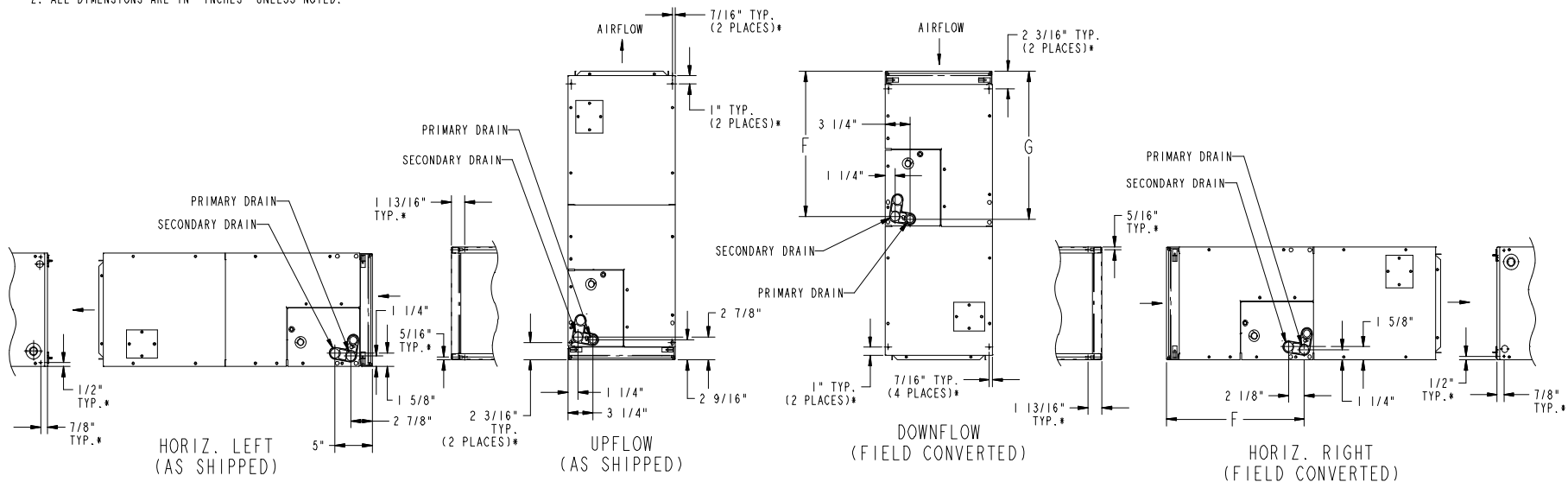

* HORIZONTAL MOUNT LOCATIONS - DIMPLES PROVIDED IN TOP PANEL, AND BACK OF CABINET. IN CABINET BOTTOM. HOLES PROVIDED .136" DIA. HORIZONTAL HANGING HARDWARE TO BE FIELD SUPPLIED.

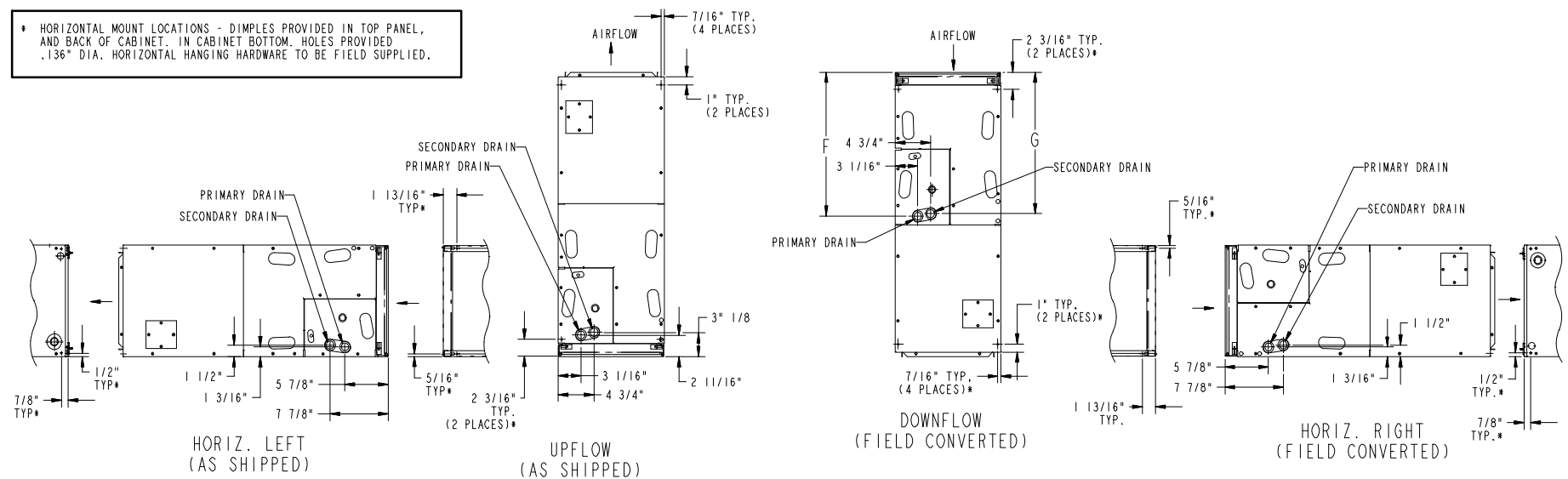

A-COIL

SD5115-4 Rev. A

Dimension English (Inches)

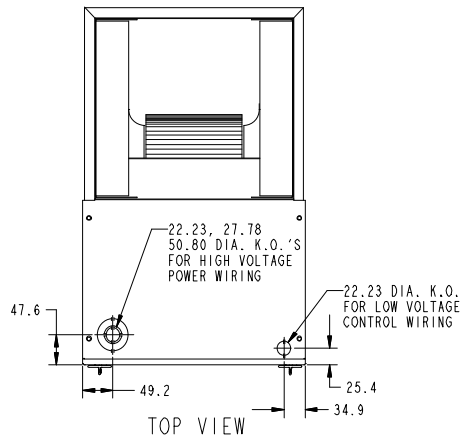

- NOTE:
1. SERIES DESIGNATION IS THE 9TH POSITION OF UNIT PRODUCT NUMBER
 2. ALL DIMENSIONS ARE IN "MM" UNLESS NOTED.

NOTE: ALLOW 533.4 FROM FRONT FOR SERVICE

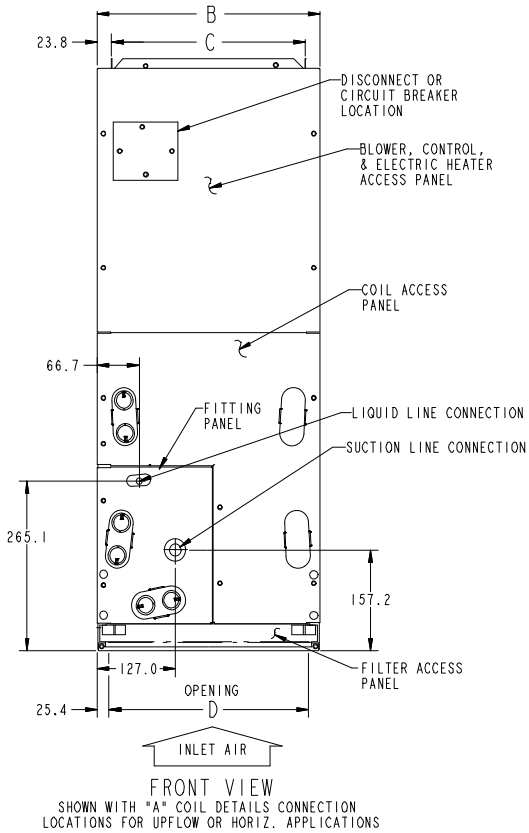

UNIT CONNECTION SIZES	
SUCTION:	018 & 024 - 15.88 I.D. SWEAT
	030 & 036 - 19.05 I.D. SWEAT
	042 THRU 060 - 22.23 I.D. SWEAT
LIQUID:	9.53 I.D. SWEAT
CONDENSATE:	19.0 FPT

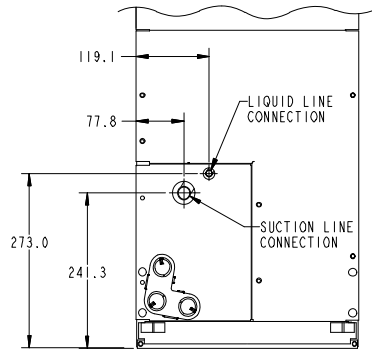

SLOPE COIL DETAILS
CONNECTION LOCATIONS SHOWN FOR UPFLOW OR HORIZ. LEFT APPLICATIONS

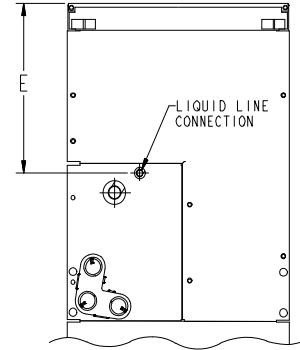

ACCESS PANEL CONFIG. FOR SLOPE COILS
DOWNFLOW OR HORIZ. RIGHT APPLICATIONS AND "A" COILS
DOWNFLOW APPLICATIONS

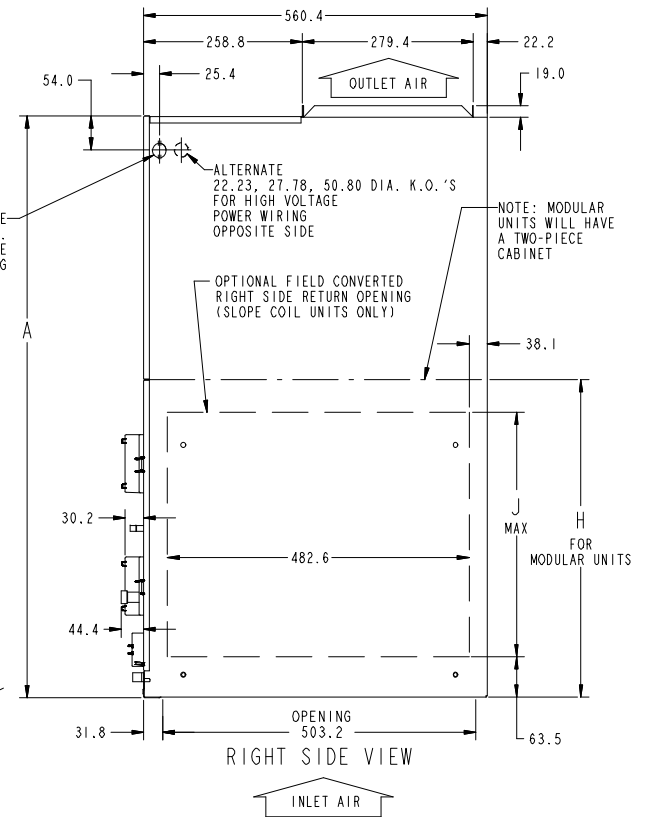

RIGHT SIDE VIEW

SD5115-4 Rev. A

Dimension mm (SI Metric)

NOTES:
 1. CONDENSATE PAN DRAIN CAPS NOT SHOWN FOR CLARITY.
 2. ALL DIMENSIONS ARE IN "MM" UNLESS NOTED.

SLOPE COIL
 Dimension English (Metric)

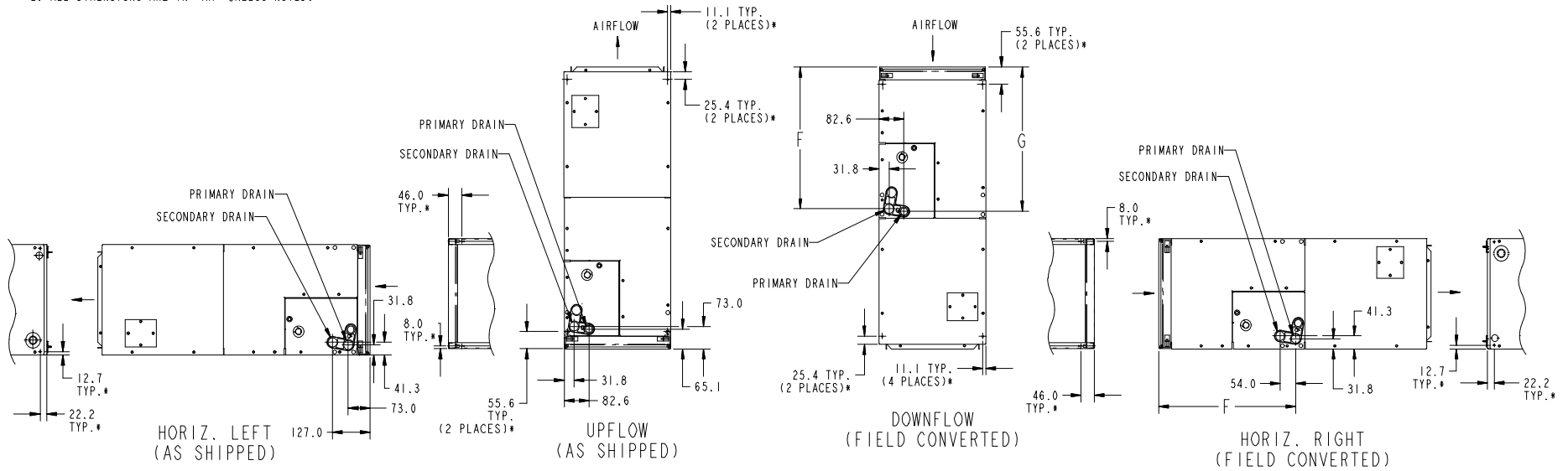

* HORIZONTAL MOUNT LOCATIONS - DIMPLES PROVIDED IN TOP PANEL, AND BACK OF CABINET. IN CABINET BOTTOM, HOLES PROVIDED 3.45 DIA. HORIZONTAL HANGING HARDWARE TO BE FIELD SUPPLIED.

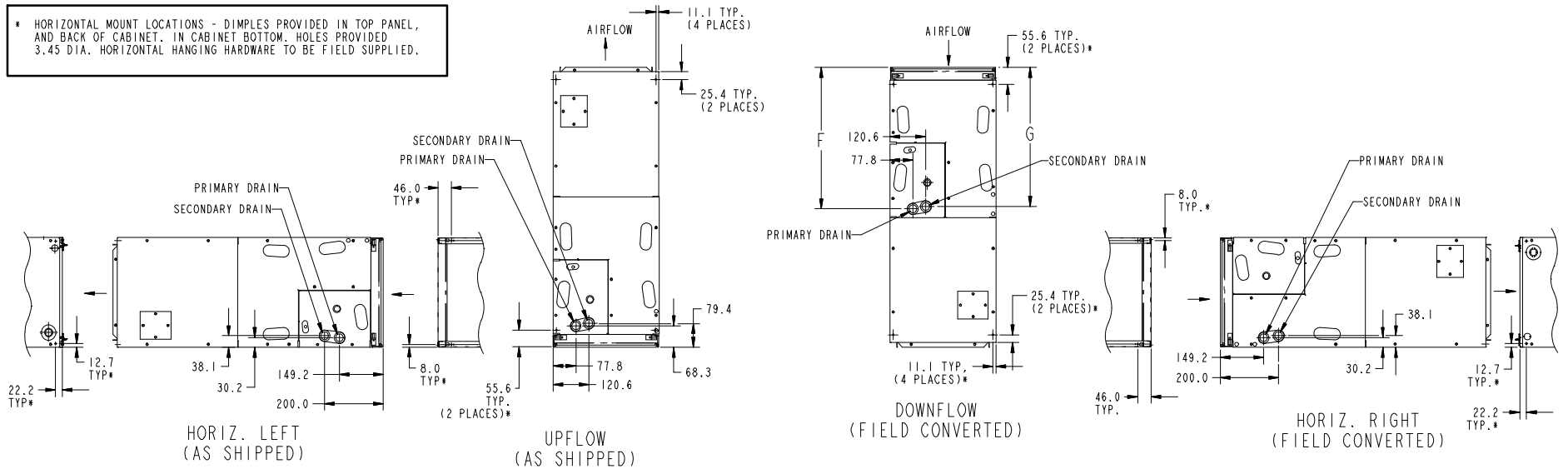

A-COIL

SD5115-4 Rev. A

Dimension mm (SI Metric)

DIMENSIONAL DATA (refer to drawings)

MODEL	SIZE (Tons)	Dimensions Inches (English)										COIL CONFIGURATION		SHIPPING WT (LBS)	SHIPPING WT (LBS)
		A	B	C	D	E	F	G	H	J	SLOPE	"A"	NON TIN-COATED	TIN-COATED	
184A	1-1/2	42-11/16	14-5/16	12-7/16	12-5/16	10-7/16	18-1/8	18-5/8	-	12	X	-	112	112	
244A	2	42-11/16	14-5/16	12-7/16	12-5/16	10-7/16	18-1/8	18-5/8	-	12	X	-	112	112	
304A	2-1/2	49-5/8	17-5/8	15-3/4	15-5/8	15-3/8	23-1/8	23-5/8	-	17	X	-	122	122	
364A	3	49-5/8	17-5/8	15-3/4	15-5/8	15-3/8	23-1/8	23-5/8	-	17	X	-	122	122	
424A	3-1/2	49-5/8	21-1/8	19-1/4	19-1/8	15-11/16	23-7/16	23-1/8	-	-	-	X	157	157	
484A	4	49-5/8	21-1/8	19-1/4	19-1/8	15-11/16	23-7/16	23-1/8	-	-	-	X	157	157	

604A	5	53-7/16	21-1/8	19-1/4	19-1/8	19-1/2	27-1/4	26-15/16	-	-	-	X	175	175
------	---	---------	--------	--------	--------	--------	--------	----------	---	---	---	---	-----	-----

MODEL	SIZE (Tons)	Dimensions mm (SI Metric)										COIL CONFIGURATION		SHIPPING WT (kg)	SHIPPING WT (kg)
		A	B	C	D	E	F	G	H	J	SLOPE	"A"	NON TIN-COATED	TIN-COATED	
184A	1-1/2	1084.3	363.6	315.9	312.8	265.1	460.4	473.1	-	304.8	X	-	50.8	50.8	
244A	2	1084.3	363.6	315.9	312.8	265.1	460.4	473.1	-	304.8	X	-	50.8	50.8	
304A	2-1/2	1260.5	447.7	400.0	396.9	390.5	587.4	600.1	-	431.8	X	-	55.3	55.3	
364A	3	1260.5	447.7	400.0	396.9	390.5	587.4	600.1	-	431.8	X	-	55.3	55.3	
424A	3-1/2	1260.5	536.6	489.0	485.8	398.5	595.3	587.4	-	-	-	X	71.2	71.2	
484A	4	1260.5	536.6	489.0	485.8	398.5	595.3	587.4	-	-	-	X	71.2	71.2	

604A	5	1357.3	536.6	489.0	485.8	495.3	692.2	684.2	-	-	-	X	79.4	79.4
------	---	--------	-------	-------	-------	-------	-------	-------	---	---	---	---	------	------

PHYSICAL DATA

Model	Size						
	184A	244A	304A	364A	424A	484A	604A
Metering Device** – Factory Installed Piston Size (R-410A)							
	52	57	67	70	76	80	TXV
Blower Data							
CFM (nominal)	600	800	1000	1200	1400	1600	1750
Motor Type	ECM 5-speed						
HP	1/3	1/3	1/3	1/2	1/2	3/4	3/4
Filter Data (washable, available as accessory)							
	13 x 21-1/2		16-3/8 x 21-1/2		19-7/8 x 21-1/2		
Coil Data – Face Area ft² (m²)							
	2.23 (0.21)	2.23 (0.21)	2.97 (0.28)	2.97 (0.28)	4.45 (0.41)	4.45 (0.41)	5.9 (0.5)
Refrigerant Line Connections (sweat)							
Liquid inch (mm)	3/8 (10)						
Suction inch (mm)	5/8 (16)	5/8 (16)	3/4 (19)	3/4 (19)	7/8 (22)	7/8 (22)	7/8 (22)

ELECTRICAL DATA, FAN COIL ONLY WITHOUT ELECTRIC HEAT			
Model Size	208/230V, single phase, 60 Hz		
	Motor Full Load Amps (FLA)	Minimum Circuit Ampacity (MCA)	Maximum Fuse/Ckt Bkr Amps (Max OverCurrent Protection – MOCP)
184A	2.8	3.5	15
244A	4.1	5.1	15
304A	2.8	3.5	15
364A	4.1	5.1	15
424A	4.1	5.1	15
484A	6.0	7.5	15
WAP(M,T)604A	6.0	7.5	15

****Always check piston size on indoor unit to see if it matches required piston on outdoor unit nameplate. If it does not match, replace indoor piston with piston size marked on outdoor unit nameplate.**

AIRFLOW PERFORMANCE – CFM at a given Speed and Static reading							
Model Size	Blower Speed	Total Static (inches water column)					
		0.10	0.20	0.30	0.40	0.50	0.60
184A	Tap 5	767	739	702	669	620	565
	Tap 4	614	569	534	486	436	398
	Tap 3	701	660	616	581	537	499
	Tap 2	614	569	534	486	436	398
	Tap 1	614	569	534	486	436	398
244A	Tap 5	969	936	892	835	763	676
	Tap 4	826	795	766	743	706	660
	Tap 3	826	795	766	743	706	660
	Tap 2	701	660	616	581	537	499
	Tap 1	617	592	552	507	472	420
304A	Tap 5	1108	1090	1065	1034	1009	974
	Tap 4	1026	1000	969	938	899	865
	Tap 3	1026	1000	969	938	899	865
	Tap 2	909	873	842	799	762	724
	Tap 1	825	795	757	722	674	634
364A	Tap 5	1301	1276	1245	1218	1176	1121
	Tap 4	1227	1191	1169	1143	1105	1074
	Tap 3	1227	1191	1169	1143	1105	1074
	Tap 2	1087	1062	1030	1001	966	930
	Tap 1	1026	1000	969	938	899	865
424A	Tap 5	1560	1544	1507	1464	1424	1358
	Tap 4	1419	1397	1358	1320	1279	1239
	Tap 3	1419	1397	1358	1320	1279	1239
	Tap 2	1249	1220	1184	1142	1093	1052
	Tap 1	1242	1205	1158	1110	1069	1026
484A	Tap 5	1743	1712	1679	1642	1610	1574
	Tap 4	1669	1634	1599	1564	1531	1499
	Tap 3	1669	1634	1599	1564	1531	1499
	Tap 2	1452	1413	1377	1339	1308	1271
	Tap 1	1300	1256	1221	1182	1142	1101
WAP(M,T)604A	Tap 5	1897	1867	1836	1808	1774	1736
	Tap 4	1817	1785	1757	1724	1693	1655
	Tap 3	1817	1785	1757	1724	1693	1655
	Tap 2	1657	1621	1589	1557	1518	1474
	Tap 1	1443	1412	1377	1332	1286	1243

■ – Airflow outside 450 cfm/ton.

NOTES:

- Airflow based upon dry coil at 230v with factory-approved filter and electric heater (2 element heater sizes 018 through 036, 3 element heater sizes 42 – 48). Airflow at 208 volts is approximately the same as 230 volts because the ECM motor is a constant torque motor. The torque doesn't drop off at the speeds the motor operates.
- To avoid potential for condensate blowing out of drain pan prior to making drain trap:
Return static pressure must be less than 0.40 in. wc.
Horizontal applications of 42 – 48 sizes must have supply static greater than 0.20 in. wc.
- Airflow above 400 cfm/ton on 48 size could result in condensate blowing off coil or splashing out of drain pan.

STATIC PRESSURE CORRECTION FROM DRY TO WET COIL (inches of water column)																
Model Size	CFM															
	500	600	700	800	900	1000	1100	1200	1300	1400	1500	1600	1700	1800	1900	2000
184A	0.034	0.049	0.063	—	—	—	—	—	—	—	—	—	—	—	—	—
244A	0.034	0.049	0.063	0.076	0.089	—	—	—	—	—	—	—	—	—	—	—
304A	—	—	—	0.049	0.059	0.070	0.080	—	—	—	—	—	—	—	—	—
364A	—	—	—	—	—	0.070	0.080	0.090	0.099	—	—	—	—	—	—	—
424A	—	—	—	—	—	—	—	0.049	0.056	0.063	0.070	—	—	—	—	—
484A	—	—	—	—	—	—	—	—	—	0.063	0.070	0.076	0.083	0.090	—	—
WAP(M,T) 604A	—	—	—	—	—	—	—	—	—	—	—	.049	.054	.059	.065	.070

MINIMUM CFM WHEN USING ELECTRIC HEAT											
Model Size	HEATER kW										
	3	5	8	9	10	15	18	20	24	30	
184A	525	525	525	—	600	—	—	—	—	—	
244A	700	700	700	—	700	775	—	—	—	—	
304A	—	875	875	—	875	875	—	1060	—	—	
364A	—	1050	970	970	970	920	—	1040	—	—	
424A	—	—	1225	1225	1225	1225	1225	1225	—	—	
484A	—	—	1400	1400	1400	1400	1400	1400	1400	1400	
WAP(M,T) 604A	—	—	1750	1750	1750	1750	1750	1750	1750	1750	

Note: Speed Tap 4 (white wire) is used for electric heat only. White wire must remain on tap 4.

STATIC PRESSURE CORRECTION FOR ELECTRIC HEATERS (inches of water column)						
Airflow performance chart was developed using fan coils with 10 kW electric heater (2 elements) in the 18 – 36 model sizes, and 15 kW electric heaters (3 elements) in the 42 – 60 model sizes.						
When using a different number of heater elements, adjust the static pressure numbers by adding or subtracting the values in this table (for a given CFM, more electric heater elements create higher static pressure drop).						
Model Size	Heater kW					
	No Heater	3 or 5	8 or 10	9 or 15	20	18, 24, or 30
	0	1	2	3	4	6
184A	+0.02	+0.01	0	-0.02	-0.04	-
244A	+0.02	+0.01	0	-0.02	-0.04	-
304A	+0.02	+0.01	0	-0.02	-0.04	-
364A	+0.02	+0.01	0	-0.02	-0.04	-
424A	+0.04	-	+0.02	0	-0.02	-0.10
484A	+0.04	-	+0.02	0	-0.02	-0.10
WAP(M,T) 604A	+0.04	-	+0.02	0	-0.02	-0.10

ELECTRIC HEATER ELECTRICAL DATA

Heater Model	Heater kW		PHASE	INTERNAL CIRCUIT PROTECTION	HEATER AMPS 208/230V			BRANCH CIRCUIT														
								Min Ampacity ☆ 208/230V			Min Wire Size (AWG) 208/230V †			Min Gnd Wire Size 208/230V			Max Fuse/Ckt Bkr Amps 208/230V			Max Wire Length 208/230V (FT) ‡		
					Single Circuit	Dual Circuit		Single Circuit	Dual Circuit		Single Circuit	Dual Circuit		Single Circuit	Dual Circuit		Single Circuit	Dual Circuit		Single Circuit	Dual Circuit	
	230v	208v				L1,L2	L3,L4		L1,L2	L3,L4		L1, L2	L3, L4		L1, L2	L3,L4		L1,L2	L3,L4		L1,L2	L3,L4
EHK05AKN*	5	3.8	1	None	18.1/20.0	—	—	26.0/28.4	—	—	10/10	—	—	10/10	—	—	30/30	—	—	66/66	—	—
EHK05AKN**	5	3.8	1	None	18.1/20.0	—	—	31.2/33.5	—	—	8/8	—	—	10/10	—	—	35/35	—	—	85/88	—	—
EHK05AKB*	5	3.8	1	Ckt Bkr	18.1/20.0	—	—	26.0/28.4	—	—	10/10	—	—	10/10	—	—	30/30	—	—	66/66	—	—
EHK05AKB**	5	3.8	1	Ckt Bkr	18.1/20.0	—	—	31.2/33.5	—	—	8/8	—	—	10/10	—	—	35/35	—	—	85/88	—	—
EHK07AKN	8	6.0	1	None	28.9/32.0	—	—	44.7/48.5	—	—	8/8	—	—	10/10	—	—	45/50	—	—	59/60	—	—
EHK07AKB	8	6.0	1	Ckt Bkr	28.9/32.0	—	—	44.7/48.5	—	—	8/8	—	—	10/10	—	—	45/50	—	—	59/60	—	—
EHK09AKCN†	9	6.8	1	None	32.8/36.0	—	—	49.5/53.5	—	—	8/6	—	—	10/10	—	—	50/60	—	—	54/87	—	—
	9	6.8	3	None	18.8/20.8	—	—	32.0/34.5	—	—	8/8	—	—	10/10	—	—	35/35	—	—	83/85	—	—
EHK10AKN	10	7.5	1	None	36.2/40.0	—	—	53.8/58.5	—	—	6/6	—	—	10/10	—	—	60/60	—	—	78/80	—	—
EHK10AKB	10	7.5	1	Ckt Bkr	36.2/40.0	—	—	53.8/58.5	—	—	6/6	—	—	10/10	—	—	60/60	—	—	78/80	—	—
EHK15AKF	15	11.3	1	Fuse	54.2/59.9	36.2/40.0	18.1/20.0	76.3/83.4	53.8/58.5	22.7/25.0	4/4	6/6	10/10	8/8	10/10	10/10	80/90	60/60	25/25	88/89	78/80	75/76
EHK15AKB	15	11.3	1	Ckt Bkr	—	36.2/40.0	18.1/20.0	—	53.8/58.5	22.7/25.0	—	6/6	10/10	—	10/10	10/10	—	60/60	25/25	—	78/80	75/76
EHK15AHN	15	11.3	3	None	31.3/34.6	—	—	47.7/51.8	—	—	8/6	—	—	10/10	—	—	50/60	—	—	56/90	—	—
EHK18AHN	18	13.5	3	None	37.6/41.5	—	—	55.5/60.4	—	—	6/6	—	—	10/8	—	—	60/70	—	—	76/77	—	—
EHK20AKF	20	15.0	1	Fuse	72.3/79.9	36.2/40.0	36.2/40.0	98.9/108.4	53.8/58.5	45.3/50.0	3/2	6/6	8/8	8/6	10/10	10/10	100/110	60/60	50/50	85/109	78/80	59/59
EHK20AKB	20	15.0	1	Ckt Bkr	—	36.2/40.0	36.2/40.0	—	53.8/58.5	45.3/50.0	—	6/6	8/8	—	10/10	10/10	—	60/60	50/50	—	78/80	59/59
EHK25AHCF‡	24	18.0	3	Fuse	50.1/55.4	—	—	71.2/77.8	—	—	4/4	—	—	8/8	—	—	80/80	—	—	94/95	—	—
	24	18.0	1	Fuse	86.7/95.5	—	—	116.9/127.9	—	—	1/1	—	—	6/6	—	—	125/150	—	—	115/116	—	—
EHK30AHCF‡	30	22.5	3	Fuse	62.6/69.2	—	—	86.8/95.0	—	—	3/3	—	—	8/8	—	—	90/100	—	—	97/98	—	—
	30	22.5	1	Fuse	109.0/120.0	—	—	144.8/158.5	—	—	0/00	—	—	6/6	—	—	150/175	—	—	117/150	—	—

FIELD MULTIPOINT WIRING OR 24 AND 30 KW SINGLE PHASE

Heater Model	Heater kW		P H A S E	Heater Amps 208/230V			Minimum Circuit Ampacity 208/230V ☆			Minimum Wire Size (AWG) 208/230V †			Min Gnd Wire Size 208/230V	Max Fuse/Ckt Bkr Amps 208/230V			Max Wire Length 208/230V (FT) ‡		
				L1, L2	L3, L4	L5, L6	L1, L2	L3, L4	L5, L6	L1, L2	L3, L4	L5, L6		L1, L2	L3, L4	L5, L6	L1, L2	L3, L4	L5, L6
	230V	208V		L1, L2	L3, L4	L5, L6	L1, L2	L3, L4	L5, L6	L1, L2	L3, L4	L5, L6		L1, L2	L3, L4	L5, L6	L1, L2	L3, L4	L5, L6
EHK25AHCF‡	24	18.0	1	28.9/32.0	28.9/32.0	28.9/32.0	44.7/48.5	36.2/40.0	36.2/40.0	8/8	8/8	8/8	10/10	45/50	40/40	40/40	59/60	73/73	73/73
EHK30AHCF‡	30	22.5	1	36.2/40.0	36.2/40.0	36.2/40.0	53.8/58.5	45.3/50.0	45.3/50.0	6/6	8/8	8/8	10/10	60/60	50/50	50/50	78/80	59/59	59/59

Notes:

- 1 Copper wire must be used. If other than uncoated (non-plated), 75° C ambient, copper wire (solid wire for 10 AWG and smaller, stranded wire for larger than 10 AWG) is used, consult applicable tables of the National Electric Code (ANSI/NFPA 70).
- * When used with Fan Coil model sizes 24, 36.
- ** When used with Fan Coil model sizes 42, 48.
- ☆ Includes blower motor amps of largest Fan Coil used with heater.
- † Supplied as single phase, field convertible to 3-phase.
- ‡ Supplied as 3-phase, field convertible to single phase, single or multiple supply circuits.
- ‡‡ Length shown is as measured one way along wire path between unit and service panel for a voltage drop not to exceed 2%.

ACCESSORIES		
Part Number	Description	Use with Models Sizes
EBAC01DSC	Disconnect Kit	use with All single-phase Heaters 5 kW thru 10 kW
EBAC01NCB	Downflow Base Kit	18, 24
EBAC02NCB		30, 36
EBAC03NCB		42, 48, 60
EBAC01DFS	Downflow Conversion Kit – Slope Coil	18, 24, 30, 36
EBAC02DFA	Downflow Conversion Kit – “A” Coil	42, 48, 60
EBAC01SPK	Single Point Wiring Kit	only for use with 15 kW & 20 kW fused heaters
Square D® part # QOU14100JBAF	Single Point Wiring Kit – Square D® Jumper Bar Assembly	Only for use with EHK15AKB and EHK20AKB breaker heaters
EBAC01FKS	Filter Kit (washable, box of 12)	18, 24
EBAC01FKM		30, 36
EBAC01FKL		42, 48
NASA00101FR	Standard Filter Rack (12 x 20 x 1 filter required)	18, 24
NASA00201FR	Standard Filter Rack (16 x 20 x 1 filter required)	30, 36
NASA00301FR	Standard Filter Rack (20 x 20 x 1 filter required)	42, 48, 60
EBAC01PLG	No Heat (Plug) Kit (box of 6)	Factory Installed
EBAC01CTK	PVC Condensate Trap Kit (box of 50)	ALL
EBAC01GSK	Downflow Gasket Kit	ALL (required for horizontal right and downflow)
NAEA40501TX	TXV Kit, R-410A, Copper or Tin Coil Only	18, 24, 30
NAEA40601TX		36, 42
NAEA40701TX		48, 60
NAEA20101TX	TXV Kit, R-22, Copper or Tin Coil Only	18, 24, 30, 36, 42
NAEA20201TX		48
NAEB40501TX	TXV Kit, R-410A, Aluminum Coil Only	WAPL184A, WAPL244A, WAPL304A
NAEB40601TX		WAPL364A, WAPL424A
NAEB40701TX		WAPL484A
NAEB20101TX	TXV Kit, R-22, Aluminum Coil Only	WAPL184A, WAPL244A, WAPL304A, WAPL364A, WAPL424A
NAEB20201TX		WAPL484A

ELECTRIC HEATERS		
Part Number	Description	Use with Model Sizes
EHK05AKN	5 kW, single phase, no internal circuit protection	ALL
EHK05AKB	5 kW, single phase, with circuit breakers	ALL
EHK07AKN	8 kW, single phase, no internal circuit protection	ALL
EHK07AKB	8 kW, single phase, with circuit breakers	ALL
EHK09AKCN	9 kW, supplied as single phase, field convertible to 3-phase, no internal circuit protection	36, 42, 48, 60
EHK10AKN	10 kW, single phase, no internal circuit protection	ALL
EHK10AKB	10 kW, single phase, with circuit breakers	ALL
EHK15AKF	15 kW, single phase, with fuses	24, 30, 36, 42, 48, 60
EHK15AKB	15 kW, single phase, with circuit breakers	24, 30, 36, 42, 48, 60
EHK15AHN	15 kW, 3-phase, no internal circuit protection	36, 42, 48, 60
EHK18AHN	18 kW, 3-phase, no internal circuit protection	42, 48, 60
EHK20AKF	20 kW, single phase, with fuses	30, 36, 42, 48, 60
EHK20AKB	20 kW, single phase, with circuit breakers	36, 42, 48, 60
EHK25AHCF	24 kW, supplied as 3-phase, field convertible to single phase, with fuses	48, 60
EHK30AHCF	30 kW, supplied as 3-phase, field convertible to single phase, with fuses	48, 60