

THIS DOCUMENT CONTAINS (5) PAGES: THE FIRST PAGE MUST BEAR AN ORIGINAL SIGNATURE & SEAL OF THE CERTIFYING PE TO BE VALID FOR USE
 (Subject to Renew July 1, 2022 or next code cycle change)

EVALUATION SUBJECT: **PAYNE SPLIT UNITS**

TER-20-33392

REPORT HOLDER:

PAYNE AIR CONDITIONING
 2000 PARKS OAKS AVE
 ORLANDO, FL 33428 USA
 (954) 247-2003 | FL. WWW.PAYNE.COM



Florida Building Code
 Seventh Edition (2020)
 International Building Code
 (2012, 2015, & 2018)

SCOPE OF EVALUATION (compliance with the following codes):

THIS IS A STRUCTURAL (WIND) PERFORMANCE EVALUATION ONLY. NO ELECTRICAL OR TEMPERATURE PERFORMANCE RATINGS OR CERTIFICATIONS ARE OFFERED OR IMPLIED HEREIN.

This Product Evaluation Report is being issued in accordance with the requirements of the Florida Building Code Seventh Edition (2020) per FBC Section 104.11.1, FMC 301.15, FBC Building Ch. 16, ASCE-7, FBC Existing Building sections 707.1, 707.2, FBC Building 1522.2, and FBC Residential M1202.1, M1301.1, FS 471.025, including Broward County Administrative Provisions 107.3.4. This Report is also in accordance with the International Building Code (2012, 2015, & 2018). The product noted on this report has been tested and/or evaluated as summarized herein. **IN ACCORDANCE WITH THESE CODES, EACH OF THESE REPORTS MUST BEAR THE ORIGINAL SIGNATURE & RAISED SEAL OF THE EVALUATING ENGINEER.**

SUBSTANTIATING DATA:

- **Product Evaluation Documents**
 Substantiating documentation has been submitted to support this TER and is summarized in the sections that follow.
- **Structural Engineering Calculations**
 Structural engineering calculations have been prepared which evaluate the product based on comparative and/or rational analysis to qualify the following design criteria:
 - Maximum allowable unit panel wind pressure connection integrity
 - Maximum allowable uplift, sliding, & overturning moment for ground and roof applications

Calculation summary for this TER is provided in the forces summary table. No 33% increase in allowable stress has been used in the design of this product. Microsoft Excel was used to carry out the calculations present in this report.

INSTALLATION:

The product(s) listed in this report shall be installed in strict compliance with this TER & manufacturer-provided model specifications. The product components shall be of the material specified in the manufacturer-provided product specifications. All screws must be installed in accordance with the applicable provisions & anchor manufacturer's published installation instructions.

LIMITATIONS & CONDITIONS OF USE:

Use of this product shall be in strict accordance with this TER as noted herein. See final page for complete limitations and conditions of use.

OPTIONS:

This evaluation is valid for all PAYNE models present in the table located on the final page.

FINISH:

Baked enamel.

NOTE: GRAPHICAL DEPICTIONS IN THIS REPORT ARE FOR ILLUSTRATIVE PURPOSES ONLY. ACTUAL UNITS MAY DIFFER SLIGHTLY IN APPEARANCE.

UNIT CASING MATERIAL:

0.86mm galvanized sheet steel ASTM A653 EDDS cold rolled steel for removable top panel. 1.14mm galvanized sheet steel ASTM A653 EDDS cold rolled steel for base pan. 0.86mm galvanized steel sheet ASTM A653 for side protector louvers, secured with #10-16 sheet metal screws into top and base pan.

INSTALLATION:

Shall follow manufacturer specifications as well as the information provided herein.

STRUCTURAL PERFORMANCE:

Models referenced herein are subject to the following design limitations:

Maximum Rated Wind Pressures*:
± 119 psf Lateral, 94 psf Uplift

- Required design wind pressures shall be determined according to the design pressure guide provided in the appendix or on a site-specific basis in accordance with ASCE 7 and applicable sections of the building code(s) being referenced in accordance with ASD methodology.
- Required design pressures shall be less than or equal to the maximum pressures listed herein.
- *Maximum Rated Wind Pressures indicate the maximum pressures that all units listed herein are approved for. Valid for at-grade and rooftop applications. See limitations herein.
- Valid for use inside and outside the High-Velocity Hurricane Zone (HVHZ).
- Site-specific wind analysis may produce alternate limitations provided maximum rated wind pressures stated herein are not exceeded.

VISIT ECALC.IO/33392

FOR ENGINEER CERTIFIED ORIGINALS
 & MORE INFORMATION ABOUT THIS DOCUMENT
 OR SCAN THIS QR CODE

VISIT ENGINEERINGEXPRESS.COM/CARRIER FOR
 ADDITIONAL PLANS, REPORTS & RESOURCES



ORIGINAL SIGNATURE AND RAISED SEAL
 OR DIGITAL SEAL REQUIRED TO BE VALID PER CODE:

ATTENTION

Scanned copies not to be used to obtain permit



Frank Bennardo, P.E. SECB If Checked, Certifying
ENGINEERING EXPRESS Engineer and PE #
FL PE #0046549 FLCA #98861 Appear Above

DIGITAL SEAL NOTICE: IF THIS DOCUMENT IS DIGITALLY SIGNED, THIS SHEET IS PART OF A DIGITALLY SIGNED FILE. IT SHALL REMAIN IN DIGITAL FORMAT, SHALL BE VERIFIED BY ELECTRONIC MEANS, & PRINTED COPIES OF THIS DOCUMENT ARE NOT CONSIDERED SIGNED AND SEALED. VISIT ECALC.IO/DS TO LEARN MORE.

PRINTED DOCUMENT NOTICE: IF THIS DOCUMENT IS PRINTED & DOES NOT CONTAIN AN ENGINEER'S ORIGINAL SIGNATURE & SEAL, THIS DOCUMENT IS VOID & NOT VALID FOR USE. PHOTOCOPIES ARE NOT PERMITTED FOR USE.

SECTION 2 PRODUCT INSTALLATION

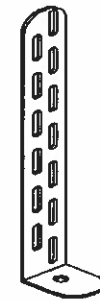
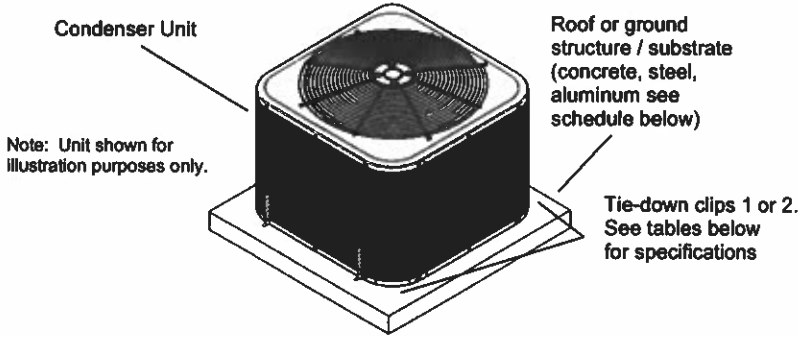

Note: Installers must ensure that screws used to fasten the tie-down clips with the unit base pan do not touch the coil in order to prevent any damage to the coil.

TIE-DOWN CLIP (1)
(GROUND AND ROOF APPLICATION)

When using Miami Tech kit # CBCUTD4KG for ground & kit # CBCUTD4KR for roof application, CUTD 1" wide ASTM A653 galvanized steel 0.07" (FL19731.2) thickness of varying length for all cabinets tied to a roof structure or ground structure, fasten number of clips per "Tie Down Strap Clip Schedule". Using qty. 2 anchors from Anchor Types to Host Structure table of #10 SS 410 self-drilling screw to fasten clip to unit base pan. Locate clips at 3" from the appropriate corner using and equal number of clips near corners on opposite sides.

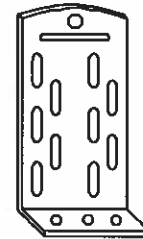

TIE-DOWN CLIP (2)
(GROUND AND ROOF APPLICATION)

When using BMP Clip part# TD042; 2" wide ASTM A283 (Grade D) steel 0.113" thickness of varying length for all cabinets tied to a roof structure or ground structure, fasten number of clips per "Tie Down Strap Clip Schedule". Using qty. 2 anchors from Anchor Types to Host Structure table and qty. 4 #12 SAE grade 5 sheet metal screws to fasten clip to unit base pan. Locate clips at 3" from the appropriate corner using and equal number of clips near corners on opposite sides.

Tie-down Strap & Clip Schedule						
Unit Model*	Max Lateral Pressure	Max Uplift Pressure	Strap Req'd?	Qty	Tie Down Clip #(1) Qty	Tie Down Clip #(2) Qty
Mini, Small, Medium	50 psf	39 psf	NO	N/A	4	4
	104 psf	83 psf	NO	N/A	8	4
Mini, Small, Medium, & Large	119 psf	93 psf	YES	2	8	4

Note: Straps shall be wrapped as shown in details on section 4. The straps shall be tightened to a snug fit around the unit. Straps shall be 1" width and 22ga galvanized metal. For Non-HVHZ, use (2) metal straps, up to 200" MRH. Values shown in table are minimum specified. Using stronger straps per each height is allowed at installer's discretion.

Anchor to Host Structure Schedule (to Concrete Slab or Metal Host)					
Unit Model*	Max Lateral Pressure	Max Uplift Pressure	Concrete 3,000 psi	1/8" Min A36 Steel	1/8" Min 6061-T6 Aluminum
Mini, Small, Medium, Large	50 psf	39 psf	A	N/A	N/A
	119 psf	94 psf	N/A	B	B

Panel Integrity Summary				
Unit Model*	Panel	Max Applied Wind Pressure	Pressure Direction	Add'l Screws Needed (pcs)
Mini, Small, Medium, Large	Top Panel	94 psf	Uplift	NONE
	Control Cover	119 psf	Lateral	NONE
	Service Panel	119 psf	Lateral	NONE

+ See tables provided below for cabinet classification

Tie-down Strap & Clip:
(for roof applications)

- Minimum edge distance 3" from the unit corners.
- Use a minimum of tie-down straps per side equally spaced.
- Clip height shall be adequate to fit SMS within base pan height. Verify height on site.
- Place an adjacent (1) #10 SMS to avoid the straps slip off.

Anchor Types to Host Structure
(to Concrete Slab or Metal Host):

A. (Concrete Slab)– 1/4" Dewalt ULTRACON SS4 Anchor embedded 1 3/4" in 3,000 psi concrete. 2 1/2" from edge minimum.

B. (Metal Host)– 1/4" -20 UNC SAE Grade 5 bolt min. 1/2" from edges with nut and washer OD 1"

NA. - No anchors apply.

IN ALL CONDITIONS IT IS THE RESPONSIBILITY OF THE PERMIT HOLDER TO ENSURE THE HOST STRUCTURE IS CAPABLE OF WITHSTANDING THE RATED GRAVITY, LATERAL, AND UPLIFT FORCES BY SITE-SPECIFIC DESIGN. NO WARRANTY OF ANY KIND, EXPRESSED OR IMPLIED, IS OFFERED BY ENGINEERING EXPRESS AS TO THE INTEGRITY OF THE HOST STRUCTURE TO CARRY DESIGN FORCE LOADS INCURRED BY THIS UNIT.

SECTION 4 DETAILS

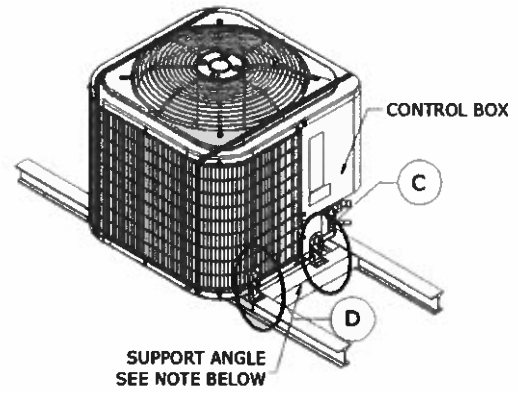
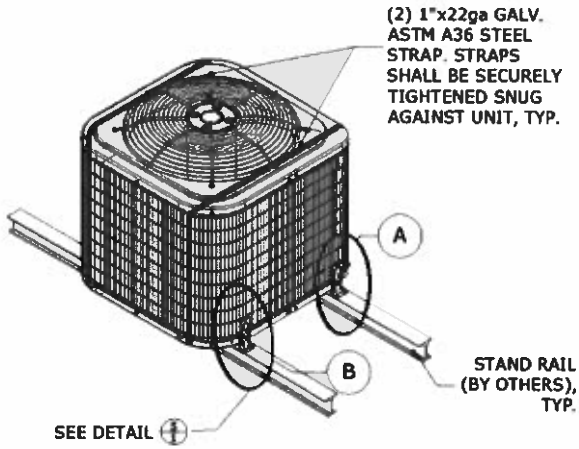

1 MECHANICAL UNIT
N.T.S. FRONT ISOMETRIC

2 MECHANICAL UNIT
N.T.S. BACK ISOMETRIC

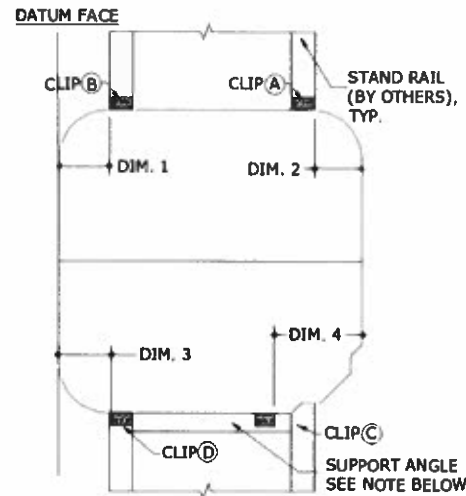
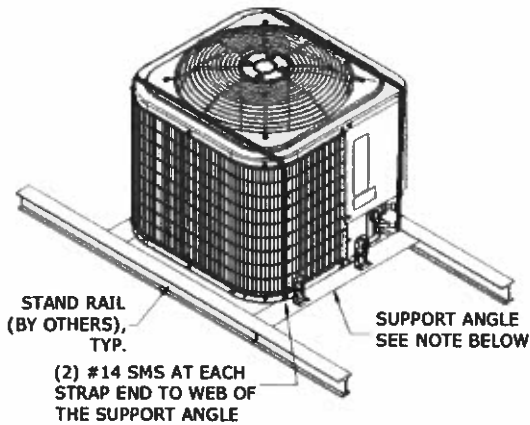

3 MECHANICAL UNIT
N.T.S. FRONT ISOMETRIC

4 TIE-DOWN CLIP LAYOUT
N.T.S. PLAN

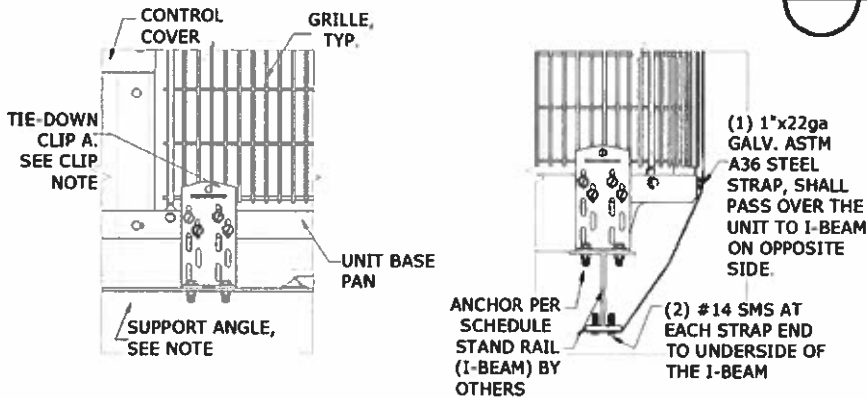

TIE-DOWN CLIP OFFSETS:

DIM. 1	5.00" MAX OFFSET FROM DATUM FACE
DIM. 2	5.00" MAX OFFSET FROM OPPOSITE FACE
DIM. 3	5.00" MAX OFFSET FROM DATUM FACE
DIM. 4	10.00" MAX OFFSET FROM OPPOSITE FACE

5 TIE-DOWN CLIPS & STRAPS
N.T.S. ELEVATION

Note:
Miami Tech support angle part number CBCAB30K, CBCAB42K, under NOA #18-0601.01 or equivalent is permitted.

CABINETS & DIMENSIONS

Unit Model	Width (In)	Depth (In)	Height (In)	Type
PH16**024	35.00	35.00	39.13	Medium
PH16**036	35.00	35.00	39.13	Medium
PH16**048	35.00	35.00	39.13	Medium
PH16**060	35.00	35.00	45.94	Large
PA17**024	31.19	31.19	35.75	Mini/Small
PA17**036	31.19	31.19	35.75	Mini/Small
PA17**048	35.00	35.00	39.13	Medium
PA17**060	35.00	35.00	45.88	Large

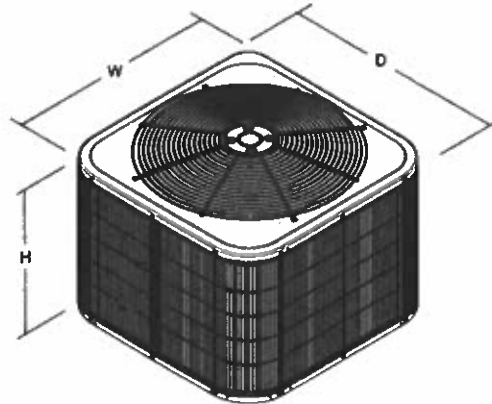

Note: Image is not to scale and is for illustration purposes only. Actual units may differ slightly in appearance.

Proj. #	Remarks	By	Checked	Date
16-3190.11	Initial Issue	LAO	FLB	9/07/16
20-33392	Update to 2020 FBC	CCB	RWN	12/16/20

LIMITATIONS & CONDITIONS OF USE:

Use of this product shall be in strict accordance with this TER as noted herein.

The supporting host structure shall be designed to resist all superimposed loads as determined by others on a site specific basis as may be required by the Authority Having Jurisdiction. Host structure conditions which are not accounted for in this product's respective anchor schedule shall be designed on a site-specific basis by a registered professional engineer. No evaluation is offered for the host supporting structure by use of this document. Adjustment factors noted herein and the applicable codes must be considered, where applicable. All supporting components which are permanently installed shall be protected against corrosion, contamination, and other such damage at all times. Fasteners must penetrate the supporting members such that the full length of the threaded portion is embedded within the main member. All anchors, screws, straps, clips, and attachment part can be substituted for equivalent parts, as long as the capacities of the equivalent parts are equal or stronger.

This evaluation does not offer any evaluation to meet large missile impact debris requirements which typically are not required for this type of product.

All of the wind resisting exterior panels, individually meet or exceed their capacity to resist the design wind loads as stated in the calculations as required by the codes and standards stated herein. Due to the indeterminate nature of these units, distortion and deflection cannot be accurately evaluated, but with diaphragm action of external components and internal stiffeners, the base unit has the capacity to withstand these forces with individual external parts being contained. Yearly inspections, during equipment maintenance or after a named storm; all screws, cabinet components, clips, anchor, bolts, straps and cables are to be verified by the A/C contractor. All damaged cabinet components, loose, corroded, broken screws or anchor bolts shall be replaced to ensure structural integrity for hurricane wind forces.

APPENDIX A: DESIGN WIND PRESSURE GUIDE

Max. Ult. Wind Speed (V _{ult})	Max. MRH (Roof Height)	Exposure Category	Required Design Wind Pressures (ASD)	
			Lateral Pressure	Uplift Pressure
140 mph	At-Grade (0 ft)	C	26 psf	21* psf
		D	31 psf	25* psf
	100 ft	C	67 psf	53 psf
		D	75 psf	59 psf
	200 ft	C	76 psf	60 psf
		D	84 psf	67 psf
175 mph	At-Grade (0 ft)	C	40 psf	32* psf
		D	49 psf	39* psf
	100 ft	C	104 psf	82 psf
		D	117 psf	93 psf
	200 ft	C	119 psf	94 psf
		D	131 psf	104 psf
186 mph	At-Grade (0 ft)	C	46 psf	36* psf
		D	55 psf	44* psf
	100 ft	C	117 psf	93 psf
		D	132 psf	105 psf
	200 ft	C	135 psf	106 psf
		D	148 psf	117 psf

indicates a design wind pressure that is not approved for use by this evaluation. Seek additional engineering or contact this office for design solutions.

DIRECTIVE: This design pressure guide is for reference only and shall be approved for use by the Authority Having Jurisdiction (AHJ). If the design pressures listed in this guide are not used, required design pressures shall be calculated on a site-specific basis by others. For site-specific scenarios classified as Exposure Category B, the required design pressures stated for Exposure Category C in the above guide shall be used or design pressures shall be calculated separately. For heights and parameters beyond the above values, consult with an engineer for a site-specific analysis.

The required ASD design pressures listed in the above guide were calculated based on the parameters listed below. The project design professional or permitting contractor shall verify that the site-specific conditions are equal to or less than the design parameters listed below.

*Note: Per the codes and standards referenced herein, uplift is optional for mechanical equipment at-grade. At the discretion of the AHJ, uplift may be taken as 0 psf or as the value listed in the guide.

At-Grade (0 ft MRH) Required Design Pressures:

- o ASCE 7 "Design Wind Loads: Other Structures"
- o Structure Shape = Square, flat terrain
- o Height of structure (unit + stand or curb, if used) = 6 ft max.
- o Width of unit = 1 ft min., Depth of unit = 1 ft min.
- o Uplift Pressure = Lateral Pressure x 1.5 / 1.9 (if considered)

Roof (>15 ft MRH) Required Design Pressures:

- o ASCE 7 "Design Wind Loads: Other Structures: Rooftop Structures and Equipment for Buildings"
- o Structure Shape = Square, flat terrain
- o z = up to 7 ft, where z = height of stand or curb + 1/2 unit height
- o Lateral GC_f = 1.90; Uplift GC_f = 1.50

VISIT ECALC.IO/FORCES

FOR HELP DETERMINING DESIGN PARAMETERS AND TO SEE MORE EXAMPLES, OR SCAN THE QR CODE TO THE RIGHT >



UNIT REACTIONS FROM WIND GUIDE

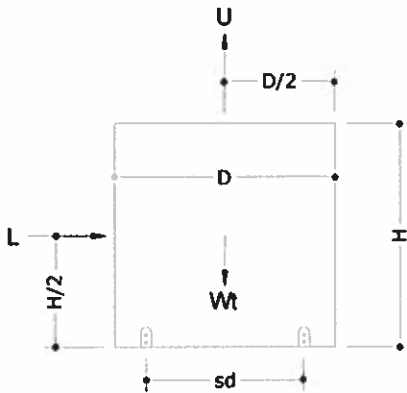

DIRECTIVE: This guide is intended for use by a project design professional. Design parameters shall abide all specifications and limitations stated in this report. Design Professional shall consider all forces, including seismic and snow loads per governing building codes. Unit reactions obtained from this guide shall be verified by a registered Professional Engineer. Reactions are applicable for unit-to-host connections only. Sample calculations are provided below.

Design Parameters:

- Lateral Wind Pressure, P_{lat}
- Unit Height, H
- Unit Width, W
- Support Spacing across Depth, sd
- Uplift Wind Pressure, P_{up}
- Unit Depth, D
- Unit Weight, Wt
- Support Spacing across Width, sw

Unit Reaction Equations:

Long Side (Width x Height):

- Sliding Force, L = P_{lat} x W x H
- Uplift Force, U = P_{up} x W x D
- Total Tension per Long Side =

$$(L \times H/2 + U \times sd/2 - Wt \times 0.6 \times sd/2) / sd$$

Short Side (Depth x Height):

- Sliding Force, L = P_{lat} x D x H
- Uplift Force, U = P_{up} x W x D
- Total Tension per Short Side =

$$(L \times H/2 + U \times sd/2 - Wt \times 0.6 \times sd/2) / sw$$

Example: A (48" W x 36" D x 42" H), 250 lb net weight unit at wind pressures of 120 psf lateral and 95 psf uplift, on a 24" wide roof stand, shall have the following unit reactions:

Long Side (Width x Height)

1. Sliding Force, L = P_{lat} x W x H = (120 psf) x (48 in) x (42 in) x (1 in² / 144 ft²) = 1680 lb
2. Uplift Force, U = P_{up} x W x D = (95 psf) x (48 in) x (36 in) x (1 in² / 144 ft²) = 1140 lb
3. Total Tension per Long Side = (L x H/2 + U x sd/2 - Wt x 0.6 x sd/2) / sd = ((1680 lb x 42/2 in) + (1140 lb x 24/2 in) - (250 lb x 0.6 x 24/2 in)) / 24 in = 1965 lb

Short Side (Depth x Height):

1. Sliding Force, L = P_{lat} x D x H = (120 psf) x (36 in) x (42 in) x (1 in² / 144 ft²) = 1260 lb
2. Uplift Force, U = P_{up} x W x D = (95 psf) x (48 in) x (36 in) x (1 in² / 144 ft²) = 1140 lb
3. Total Tension per Short Side = (L x H/2 + U x sd/2 - Wt x 0.6 x sd/2) / sw = ((1260 lb x 42/2 in) + (1140 lb x 24/2 in) - (250 lb x 0.6 x 24/2 in)) / 48 in = 1046 lb

IN ALL CONDITIONS IT IS THE RESPONSIBILITY OF THE PERMIT HOLDER TO ENSURE THE HOST STRUCTURE IS CAPABLE OF WITHSTANDING THE RATED GRAVITY, LATERAL, AND UPLIFT FORCES BY SITE-SPECIFIC DESIGN. NO WARRANTY OF ANY KIND, EXPRESSED OR IMPLIED, IS OFFERED BY ENGINEERING EXPRESS AS TO THE INTEGRITY OF THE HOST STRUCTURE TO CARRY DESIGN FORCE LOADS INCURRED BY THIS UNIT.