

Optional Mounting

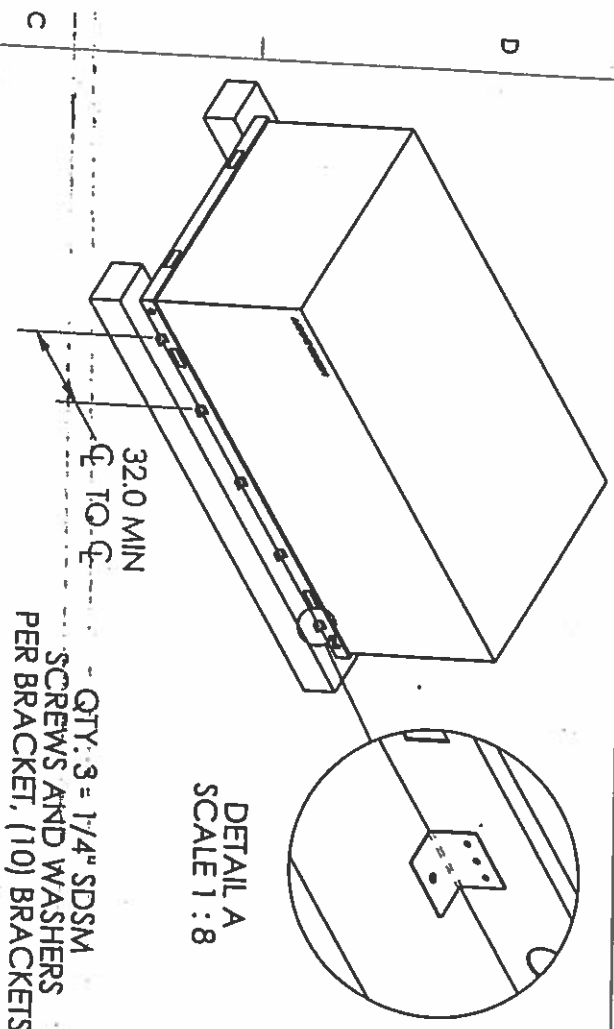

QTY. 1 - 3/8" SAE GR5 BOLT, NUT AND WASHER PER BRACKET INTO PROPERLY DESIGNED METAL STAND (BY OTHERS)
OR
QTY. 1 - 3/8" POWERS WEDGE-BOLT+ ANCHOR PER BRACKET INTO MINIMUM 2000 PSI CONCRETE (BY OTHERS), AS FOLLOWS:
2-1/8" MIN EMBED
2-3/4" EDGE DISTANCE
2-1/2" MIN SPACING

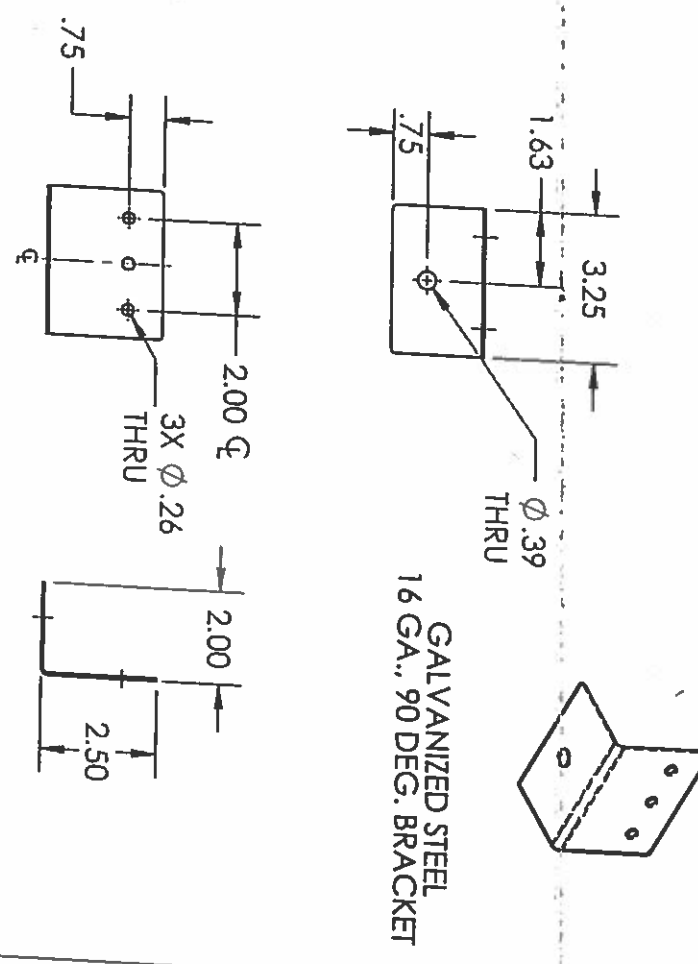

BRYANT Chassis 6, 7, 8 & 9:
Models:
580J/558J - size 17 (min) through size 30 (max)
548J - size 17 (min) through size 24 (max)
581J/551J - size 17 (min) through size 28 (max)

Each condenser unit listed above conforms to the Florida Building Code 6th Edition (2017) requirements for installation including High Velocity Hurricane Zone (HVHZ), Risk Category III/IV (V = 186 MPH), exposure category "D", and installation height up to and including 65 feet above grade.

Worst Case is -26 (Chassis 9) 1 57-3/4" x 86-3/8" x 57-3/8"

ALLOWABLE DESIGN PRESSURES FOR THE UNIT ITSELF:

Design Lateral Pressure = 197.2 psf

Design Uplift Pressure = 95.4 psf

Unit itself will withstand wind loads imposed by 197.2 psf lateral and 95.4 psf uplift design pressures, provided the 16 GA. galvanized base rails are fastened to a properly designed concrete slab, metal stand, curb, curb adapter, or other suitable mounting arrangement and all factory supplied assembly fasteners are in place.

Curb Mounting

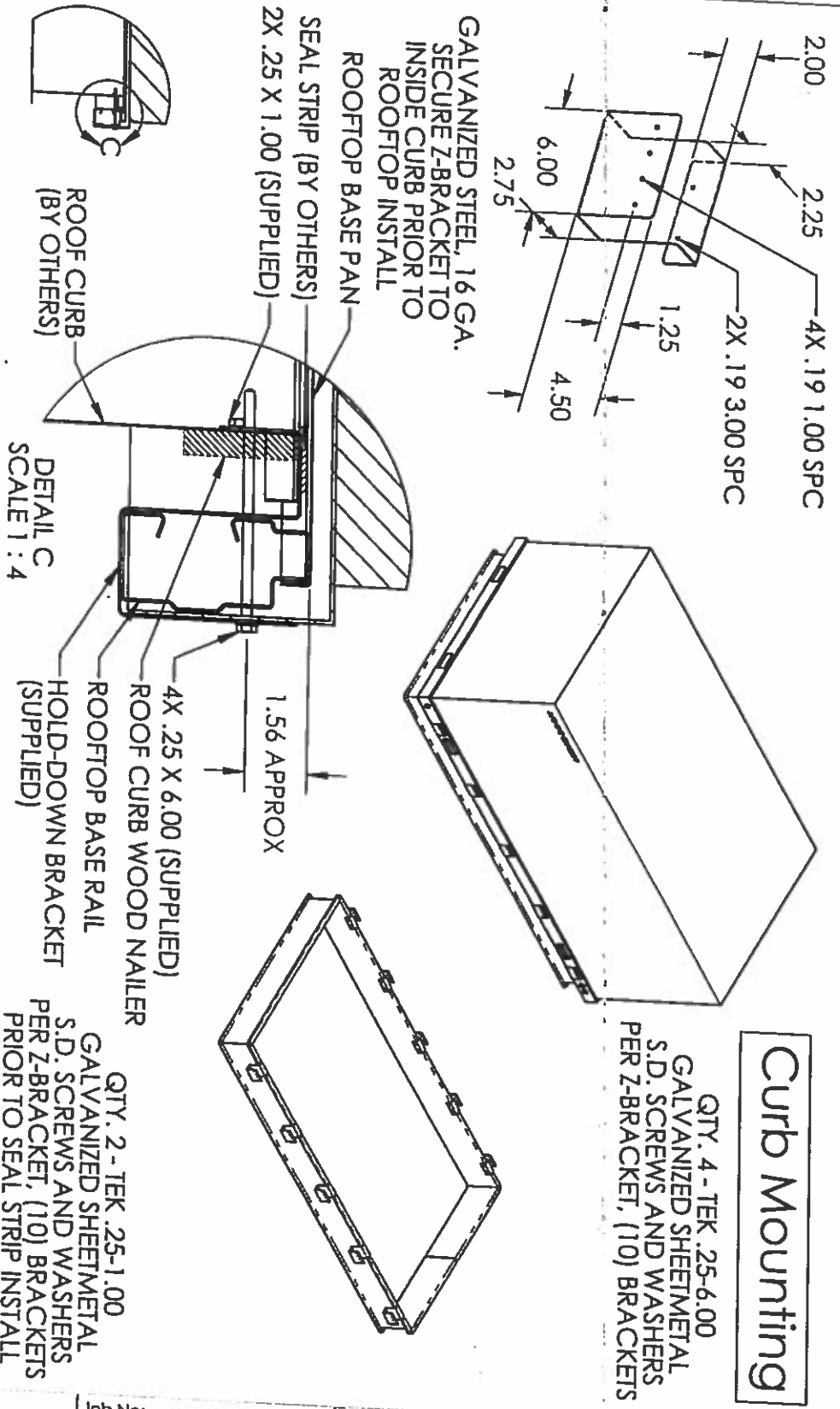

Job No: Chassis 6, 7, 8 & 9	Job No:
Date: 2-11-16	Title: Bryant RTUs
Created by: CORE	Title: Model List and Details

AUG 10 2018
Pompano Beach, FL 33064
954-509-4699

Rational Analysis: Worst case is - 24 (Chassis 9) 157-3/4" x 86-3/8" x 57-3/8"

Design Pressures complying to FBC Building 1620.6 (HVHZ):
 V = 186 mph (Risk Cat. III/IV), For Exp. Cat. "D" and Z = 65 ft, Kz = 1.33, Kzt = 1.0, Kd = 0.90
 Qz = .00256KzKztKdV² = 106.0 psf
 Using 1620.6,
 Lateral Wind Pressure = WL = qz(3.1) = 328.6 psf
 Uplift Wind Pressure = UL = qz(1.5) = 159.0 psf
 Factoring in the required Load Combination factor (0.6):

Design Lateral Pressure = WL(0.6) = 197.2 psf
 Design Uplift Pressure = UL(0.6) = 95.4 psf

Since positive pressure acts toward the surface being considered and negative pressure acts away, only the uplift pressure will remove a panel from the machine. The design lateral pressure which is considered to act toward the windward surface is recognized to be a combination of the pressures acting on the windward and leeward surfaces. Wall pressure coefficients from ASCE7-10, Chapter 27, Figure 27.4-1 may be used to distribute the Design Lateral Pressure into positive and negative components acting on the windward and leeward surfaces, respectively.

L/B = 86.375/157.75 = 0.55 for wind on long (157-3/4") side
 L/B = 157.75/86.375 = 1.83 for wind on short (86-3/8") side

Worst case positive pressure coefficient is 0.8 for windward wall which has a corresponding negative pressure coefficient of 0.5 on the leeward wall. The worst case negative pressure coefficient is 0.7 for the sidewall (side parallel to wind). Since the windward and leeward wall pressures act in the same direction, the distributed pressures are computed as follows:

Lateral Positive Design Pressure = 197.18 (0.8) / (0.8 + 0.5) = 121.34 lb/ft² (Worst Case Positive)
 Lateral Negative Design Pressure = 197.18 (0.5) / (0.8 + 0.5) = 75.84 lb/ft²
 Sidewall Negative Design Pressure = 197.18 (0.7) / (0.8 + 0.5) = 106.17 lb/ft² (Worst Case Negative)

22, 20, and 18 ga. panels and columns are fastened together and to 16 ga. base rails using #10 serrated washer head self tapping screws having 0.425" head diameter, 0.19" nominal diameter, and 0.14 minor diameter. These screws are expected to exhibit the following properties based upon ICC-ES Report ESR-2196:

Pullout Strength in 22 ga. = 306 lbs (ultimate) Pullout Strength in 20 ga. = 351 lbs (ultimate)
 Pullover Strength of 22 ga. = 828 lbs (ultimate) Pullover Strength of 20 ga. = 993 lbs (ultimate)
 Shear Strength in 22 ga. = 684 lbs (ultimate) Shear Strength in 20 ga. = 684 lbs (ultimate)
 Pullout Strength in 18 ga. = 450 lbs (ultimate)
 Shear Strength in 16 ga. = 927 lbs (ultimate)

For Top Panel Assembly (50HES00275 and 50HES00276 joined using 6 screws):
 85.0" x 82.5" draw formed 20 ga. assembly anchored at edges and through top to 16 ga. center panel, 18 ga. end panel assembly, 20 ga. side panels, and 18 ga. control box. This portion is over air handler section and is worst case since condenser section has three large holes in the top causing internal and external pressure to be equal.

A = 85.0(82.5)/12(12) = 48.70 sqft
 Load = 48.70(95.41) = 4646.3 lbs
 For 8 (min) screws each 85.0" side into 18 ga. (min) panels and 12 screws each 82.5" side into 20 ga. (min) side panels:
 Screw Load = 4646.3/2(8 + 12) = 116.2 lbs
 Safety Factor = 684/116.2 = 5.9
 OK for Components and Cladding

For End Panel Assembly (50HES00719 and 50HES00762 joined together using 7 screws):
 73.0" x 53.5" draw formed 18 ga. panel anchored at edges with 5 screws through top panel into face at top, 5 screws each vertical edge face into 22 ga. (min) corner posts, and 5 screws at 3/8" inch above bottom edge through panel into base rail.

A = 73.0(53.5)/12(12) = 27.12 sqft
 Load = 27.12(106.17) = 2879.5 lbs
 Screw Load = 2879.5/2(5+5) = 143.97 lbs
 Safety Factor = 306/143.97 = 2.1

For Access Panel (50HES00423):
 53.30" x 25.61" draw formed 22 ga. panel anchored with 3 screws through face each vertical side, 2 screws through face at bottom edge into 16 ga. base rail, and top edge fits inside top panel (trapped).

A = 53.5(26.4)/12(12) = 9.81 sqft
 Load = 9.81(106.17) = 1041.4 lbs
 Screw Load = 1041.4/2(3 + 3) = 86.78 lbs
 Safety Factor = 306/86.78 = 3.5

OK for Components and Cladding
 Remaining panels are trivial cases of the above due to greater fastener quantity or having openings that limit negative pressure effects.

For connection of upper frame and panels to base rails:
 12 screws each long side fasten frame posts and 20 ga. (min) panels to the long 16 ga. base rails. 8 screws fasten inside panel to short base rail at air handler end. Opposite end is louvered and has a large opening in the top and mesh over cooling coils.

Lateral Wind Area = AL = 156.0(53.625)/12(12) = 58.09 sqft
 Lateral Design Load = 58.09(197.18) = 11454.9 lbs
 Overturning Moment = 11454.9(53.625)/2 = 307135 in-lb

Uplift Wind Area = AU = 156.0(85.0)/12(12) = 92.08 sqft
 Uplift Design Load = 92.08(95.41) = 8785.7 lbs
 Uplift Moment = 8785.7(85.0)/2 = 373391 in-lb

Screw Load = (307135 + 373391)/(16 + 8)(85.0) = 333.6 lbs (shear)
 Safety Factor = 927/333.6 = 2.8
 OK for Components and Cladding

Unit itself will withstand wind loads imposed by 197.18 psf lateral and 95.41 psf uplift design pressures provided the 16 gage galvanized base rails are properly fastened to a suitable slab, stand, curb, curb adapter, or other suitable mounting arrangement and all factory supplied assembly fasteners are in place.

For connection of unit base rails to properly designed curb, metal stand, or structural concrete (by others):

Lateral Wind Area = AL = 157.75(57.375)/12(12) = 62.85 sqft
 Lateral Design Load = 62.85(197.18) = 12393.5 lbs
 Overturning Moment = 12393.5(57.375)/2 = 355537 in-lb
 Uplift Wind Area = AU = 157.75(86.375)/12(12) = 94.6 sqft
 Uplift Design Load = 94.6(95.41) = 9022.48 lbs
 Uplift Moment = 7679.1(76.875)/2 = 295167 in-lb

For connection of 16 ga. (min) straps, clips, or brackets spaced 32" (min) apart to unit base rails Using 1/4" (#14) self-drilling screws:

Pullout Strength in 16 ga. = 573 lbs (ultimate)
 Shear Strength in 16 ga. = 1389 lbs (ultimate)

Using (3) screws per strap, clip, or bracket, with 5 straps, clips, or brackets each long side:
 Screw Load = (355537 + 295167)/3(5)(86.375) = 502.3 lbs (shear) at base rail outer surface
 Safety Factor = 1389/502.3 = 2.8
 OK for Components and Cladding

For (5) Z-Brackets each long side similar to Micromet design but modified to eliminate hidden structural fasteners anchored to 18 ga. (min) curb (by others):

Shear Strength in 18 ga. = 1218 lbs (ultimate)

Screw Load = (355537 + 295167)/3(5)(76.875) = 564.3 lbs (shear) at curb inside surface
 Safety Factor = 1218/564.3 = 2.2
 OK for Components and Cladding

For quantity (5) angle clips 3.25" wide x 2" x 2-1/2", 16 ga. (min), spaced 32" (min), on-center each long side:

Anchor Load = (355537 + 295167)/5(87.125) = 1493.8 lbs (tension)
 Anchor Load = 12393.5/10 = 1239.4 lbs (shear) at 3/4" beyond base rail outer surface

For 3/8" SAE Gr. 5 bolts with nuts and washers to steel (by others):
 Safety Factor = 3720/1493.8 = 2.5 (tension) OK
 Safety Factor = 1937/1239.4 = 1.6 (shear) OK

For 3/8" Powers Wedge-Bolt + anchors with 2-1/8" (min) embedment into 2000 psi (min) concrete (by others), 4" (min) thick, 2-3/4" (min) edge distance, and 2-1/2" (min) spacing:
 Safety Factor = 3000/1493.8 = 2.0 (tension) OK
 Safety Factor = 3100/1239.4 = 2.5 (shear) OK

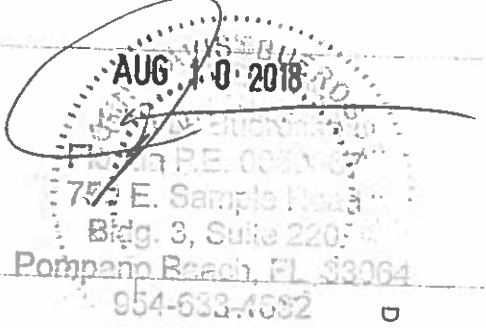

Job No: Bryant RTUs
 Title: Model List and Details

Job No: Chassis 6, 7, 8 & 9
 Date: 1-08-16
 Created by: CORE