

160 SW 12TH AVE SUITE 106, DEERFIELD BEACH, FL 33442
 (954) 354-0660 | ENGINEERINGEXPRESS.COM

THIS DOCUMENT CONTAINS (5) PAGES: THE FIRST PAGE MUST BEAR AN ORIGINAL SIGNATURE & SEAL OF THE CERTIFYING PE TO BE VALID FOR USE

(Subject to Renew January 1, 2021 or next code cycle change)

EVALUATION SUBJECT: CARRIER AC & HEAT PUMP UNITS
TER-17-5091.1
REPORT HOLDER:

 CARRIER ENTERPRISE OF FLORIDA
 2000 PARKS OAKS AVE
 ORLANDO, FL 33428 USA
 (954) 247-2003 | FL.CARRIERENTERPRISE.COM

Florida Building Code Sixth Edition (2017)

SCOPE OF EVALUATION (compliance with the following codes):
THIS IS A STRUCTURAL (WIND) PERFORMANCE EVALUATION ONLY. NO ELECTRICAL OR TEMPERATURE PERFORMANCE RATINGS OR CERTIFICATIONS ARE OFFERED OR IMPLIED HEREIN.

This Product Evaluation Report is being issued in accordance with the requirements of the Florida Building Code Sixth Edition (2017) per FBC Section 104.11.1, FMC 301.15, FBC Building Ch. 16, ASCE-7-10, FBC Existing Building sections 707.1, 707.2, FBC Building 1522.2, and FBC Residential M1202.1, M1301.1, FS 471.025, including Broward County Administrative Provisions 107.3.4. The product noted on this report has been tested and/or evaluated as summarized herein.

IN ACCORDANCE WITH THESE CODES EACH OF THESE REPORTS MUST BEAR THE ORIGINAL SIGNATURE & RAISED SEAL OF THE EVALUATING ENGINEER.
SUBSTANTIATING DATA:
• Product Evaluation Documents

Substantiating documentation has been submitted to support this TER and is summarized in the sections that follow.

• Structural Engineering Calculations

Structural engineering calculations have been prepared which evaluate the product based on comparative and/or rational analysis to qualify the following design criteria:

- Maximum allowable unit panel wind pressure connection integrity
- Maximum allowable uplift, sliding, & overturning moment for ground and roof applications

Calculation summary for this TER is provided in the forces summary table. No 33% increase in allowable stress has been used in the design of this product. Microsoft Excel was used to carry out the calculations present in this report.

INSTALLATION:

The product(s) listed in this report shall be installed in strict compliance with this TER & manufacturer-provided model specifications.

The product components shall be of the material specified in the manufacturer-provided product specifications. All screws must be installed in accordance with the applicable provisions & anchor manufacturer's published installation instructions.

LIMITATIONS & CONDITIONS OF USE:

Use of this product shall be in strict accordance with this TER as noted herein. See final page for complete limitations and conditions of use.

OPTIONS:

This evaluation is valid for all CARRIER models present in the table located on the final page.

FINISH:

Baked enamel.

NOTE: GRAPHICAL DEPICTIONS IN THIS REPORT ARE FOR ILLUSTRATIVE PURPOSES ONLY. ACTUAL UNITS MAY DIFFER SLIGHTLY IN APPEARANCE.
UNIT CASING MATERIAL:

0.86mm galvanized sheet steel ASTM A653 EDDS cold rolled steel for removable top panel. 1.14mm galvanized sheet steel ASTM A653 EDDS cold rolled steel for base pan. Side protector steel grille ASTM A510 Ø2.03mm vertical wire and Ø2.68mm horizontal wire, secured with #10-16 sheet metal screws into top and base pan.

INSTALLATION:

Shall follow manufacturer specifications as well as the information provided herein.

STRUCTURAL PERFORMANCE:

Models referenced herein are subject to the following design limitations: ASCE7-10 Exposure Category C, Risk II

Up to and including 175mph (Vult) for up to 200' MRH**. HVHZ**

Up to and including 170mph (Vult) for up to 250' MRH**. HVHZ**

Up to and including 200mph (Vult) for up to 56' MRH**. Non-HVHZ***

Ground or Roof Application per installation instructions

Mean Roof Height *High Velocity Hurricane Zone

Maximum Rated Wind Pressure:
193psf Lateral, 93psf Uplift (ASD)

Site specific wind analysis may produce alternate limitations provided maximum rated wind pressure is not exceeded.

Find this report and all the help you need at

EngineeringExpress.com/Carrier
ABOUT THIS DOCUMENT:

ENGINEER CERTIFIED ORIGINALS, VARIATIONS & HELP CAN BE FOUND BY VISITING THE WEB ADDRESS FOUND HERE BY VISITING THE WEB ADDRESS OR SCANNING THE QR CODE TO THE RIGHT >

 VISIT ENGINEERINGEXPRESS.COM/STORE FOR MORE REPORTS

ecalculator/1750911
ORIGINAL SIGNATURE AND RAISED SEAL OR DIGITAL SEAL REQUIRED TO BE VALID PER CODE:

July 23, 2019

Frank L. Bennardo, P.E., SECB

 Signed by If checked:

ENGINEERING EXPRESS®

Gordon DiBattisto, PE

FL PE #0046849

FLCA #9885

FL PE #82328

NOTICE: IF THIS PAGE DOES NOT CONTAIN AN ORIGINAL SIGNATURE & ENGINEER SEAL: IF THERE IS A DIGITAL SIGNATURE ON PAGE 1, THIS DOCUMENT IS PART OF A DIGITALLY SIGNED FILE, SHALL REMAIN IN DIGITAL FORMAT & PRINTED COPIES OF THIS DOCUMENT ARE NOT CONSIDERED SIGNED AND SEALED. IF THERE IS NO DIGITAL SIGNATURE ON PAGE 1 OR THIS PAGE DOES NOT CONTAIN AN ENGINEER'S ORIGINAL SIGNATURE & SEAL, THIS DOCUMENT IS A COPY/DRAFT.

Copyright © Engineering Express® All Rights Reserved

SECTION 2 PRODUCT INSTALLATION

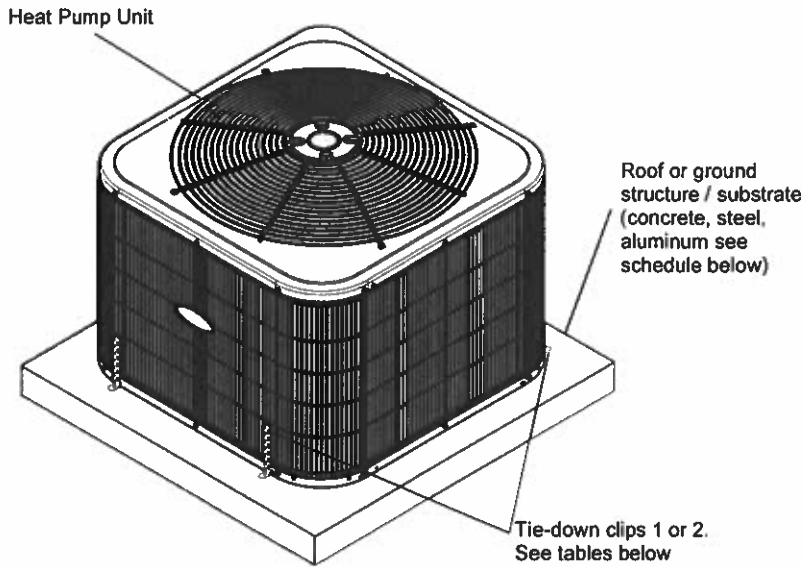

Note: Unit shown for illustration purposes only.

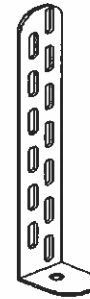

Note: Installers must ensure that screws used to fasten the tie-down clips with the unit base pan do not touch the coil in order to prevent any damage to the coil.

TIE-DOWN CLIP (1)
(GROUND AND ROOF APPLICATION)

Miami Tech CUTD 1" wide ASTM A653 galvanized steel 0.07" thick of varying length or equivalent for all cabinets tied down to a roof structure or ground structure; fasten clip to structure using anchor from Anchor Schedule to Host Structure Table and (2) #10 SS 410 self-drilling screw to fasten clip to unit base pan. Install in unit with quantities shown in Tie-down Strap & Clip Schedule. Locate clips at 3" min away from the appropriate corner using four clips per side (two at each corner) and four clips opposite side in the same configuration. Miami Tech kit # CBCUTD4KG for ground & kit # CBCUTD4KR for roof application.

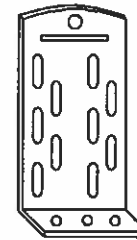

TIE-DOWN CLIP (2)
(GROUND AND ROOF APPLICATION)

BMP Clips 2" wide ASTM A283 (Grade D) steel 0.113" thick of varying length for all cabinets tied down to a roof structure or ground structure or equivalent clips; fasten clip to structure using (2) anchor from Anchor Schedule to Host Structure Table and (4) #12 SAE Grade 5 sheet metal screw to fasten clip to unit base pan. Install in unit with quantities shown in Tie-down Strap & Clip Schedule. Locate clips at 3" from the appropriate corner. BMP part number TD-042.

TIE-DOWN STRAP & CLIP SCHEDULE

Cabinet ⁺	Ground or Roof Height*	Tie-down Strap	Strap	Tie-down Clips (1)	Tie-down Clips (2)
Table 1	Ground	NA	NA	8	4
	Up to 60' (80')	2	Required	8	4
	Up to 120' (150')	2	Required	8	4
	Up to 200' (250')	2	Required	8	4
Table 2	Ground	NA	NA	8	4
	Up to 60' (80')	2	Required	8	4
	Up to 120' (150')	2	Required	8	4
	Up to 200' (250')	2	Required	8	4

*The value shown in parentheses indicates the allowable roof height in 170mph conditions. i.e. 60' (80') indicates an allowable roof height of 60' for 175mph or 80' for 170mph Vult.

+ See tables on last page for cabinet classification.

Note: Straps shall be wrapped as shown in detail on section 4. The straps shall be tightened to a snug fit around the unit. Straps shall be 1" width and 22ga galvanized metal. For Non-HVHZ, use (2) metal straps, up to 200' MRH. Values shown in table are minimum specified. Using stronger straps per each height is allowed at installer's discretion.

ANCHOR TO HOST STRUCTURE SCHEDULE

Unit Model ⁺	Ground or Roof Height*	Anchor Type		
		Concrete 3,000 Psi	1/8" Min A36 Steel	1/8" Min 6061-T6 Aluminum
Table 1	Ground	A	NA	NA
	Up to 60' (80')	NA	B	B
	Up to 120' (150')	NA	B	B
	Up to 200' (250')	NA	B	B
Table 2	Ground	A	NA	NA
	Up to 60' (80')	NA	B	B
	Up to 120' (150')	NA	B	B
	Up to 200' (250')	NA	B	B

Tie-down Strap & Clip:
(for roof applications)

- Minimum edge distance 3" from the unit corners.
- Use a minimum of tie-down straps per side equally spaced.
- Clip height shall be adequate to fit SMS within base pan height. Verify height on site.
- Place an adjacent (1) #10 SMS to avoid the straps slip off.

Anchor Types to Host Structure:

A. - 1/4" ELCO ULTRACON SS4 Anchor embedded 1 3/4" in 3,000 psi concrete. 2 1/2" from edge minimum. NOA No. 13-1205.05

B. - 1/4" -20 UNC SAE Grade 5 bolt min. 1/2" from edges with nut and washer OD 1"

NA. - No anchors apply.

IN ALL CONDITIONS IT IS THE RESPONSIBILITY OF THE PERMIT HOLDER TO ENSURE THE HOST STRUCTURE IS CAPABLE OF WITHSTANDING THE RATED GRAVITY, LATERAL, AND UPLIFT FORCES BY SITE-SPECIFIC DESIGN. NO WARRANTY OF ANY KIND, EXPRESSED OR IMPLIED, IS OFFERED BY ENGINEERING EXPRESS AS TO THE INTEGRITY OF THE HOST STRUCTURE TO CARRY DESIGN FORCE LOADS INCURRED BY THIS UNIT.

SECTION 3 SUPPORTING CALCULATIONS & SUMMARY

FORCES SUMMARY

Unit Model*	Ground or Roof Height*	Lateral Pressure (Psf)	Uplift Pressure (Psf)	Large Side Force (lbs)	Large Side Overturn (lbs-in)	Large Side Tension (lbs)	Short Side Force (lbs)	Short Side Overturn (lbs-in)	Short Side Tension (lbs)	Uplift Force (lbs)
Table 1	Ground	43.2	0	482.0	11082.0	315.0	482.0	11082.0	315.0	0.0
	Up to 60' (80')	151.2	73.1	1688.0	49656.0	1519.0	1688.0	49656.0	1519.0	622.0
	Up to 120' (150')	173.8	84.1	1940.0	57082.3	1753.0	1940.0	57082.3	1753.0	715.0
	Up to 200' (250')	193.0	93.4	2155.0	63393.3	1951.0	2155.0	63393.3	1951.0	794.0
Table 2	Ground	43.2	0	482.0	11082.0	315.0	482.0	11082.0	315.0	0.0
	Up to 60' (80')	151.2	73.1	1688.0	49656.0	1519.0	1688.0	49656.0	1519.0	622.0
	Up to 120' (150')	173.8	84.1	1940.0	57082.3	1753.0	1940.0	57082.3	1753.0	715.0
	Up to 200' (250')	193.0	93.4	2155.0	63393.3	1951.0	2155.0	63393.3	1951.0	794.0

Calculations performed according to the information provided by the client. Cabinets were assumed solid (0% porosity) for shear and tension calculation purposes.

PANEL INTEGRITY SUMMARY

Unit Model*	Ground or Roof Height*	Panel Name	Applied Wind Pressure (lb/ft²)	Force on Panel (lbs)	Add'l Screw Qty Needed (pcs)	Additional reinforcement required beyond original manufacturing
Table 1	Ground	TOP PANEL	0.0	0.0	-	No
		CONTROL COVER	43.2	50.4	-	
		SERVICE PANEL	43.2	91.4	-	
	Up to 60' (80')	TOP PANEL	73.1	621.9	-	No
		CONTROL COVER	151.2	176.5	-	
		SERVICE PANEL	151.2	319.9	-	
	Up to 120' (150')	TOP PANEL	84.1	715.4	-	No
		CONTROL COVER	173.8	202.9	-	
		SERVICE PANEL	173.8	367.7	-	
	Up to 200' (250')	TOP PANEL	93.4	794.5	-	No
		CONTROL COVER	193.0	225.3	-	
		SERVICE PANEL	193.0	408.4	-	
Table 2	Ground	TOP PANEL	0.0	0.0	-	No
		LOUVER 1	44.1	436.6	-	
		LOUVER 2	44.1	362.7	-	
		LOUVER 3	44.1	212.6	-	
		LOUVER 4	44.1	243.9	-	
		CONTROL COVER	44.1	63.5	-	
	Up to 200' (250')	TOP PANEL	93.4	794.5	0	Yes
		LOUVER 1	193.0	1909.0	2	
		LOUVER 2	193.0	1585.8	2	
		LOUVER 3	193.0	929.6	3	
		CONTROL COVER	193.0	277.4	0	

*The value shown in parentheses indicates the allowable roof height in 170mph conditions. i.e. 60' (80') indicates an allowable roof height of 60' for 175mph or 80' for 170mph Vult.

*See tables on last page for cabinet classification and model numbers.

Note: any Louver panels *contained* by straps or clips shall *not* be reinforced, otherwise reinforce with #10 410 SS screws; amount of screws required are dictated by panel integrity table. Place screw at the bottom part of the louver, joining the louver with the base pan.

SECTION 4 DETAILS

Note: Image is not to scale and is for illustration purposes only. Actual units may differ slightly in appearance.

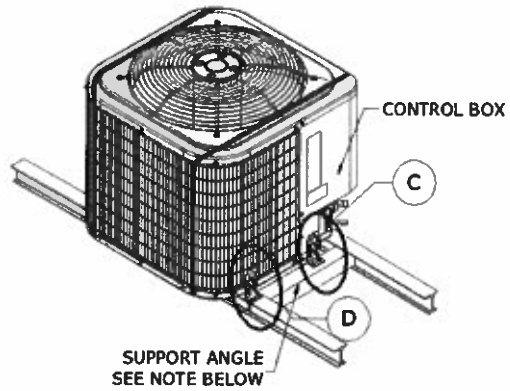
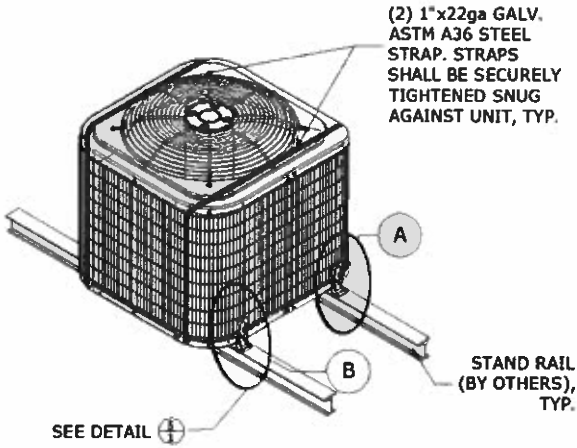

1 MECHANICAL UNIT
N.T.S. FRONT ISOMETRIC

2 MECHANICAL UNIT
N.T.S. BACK ISOMETRIC

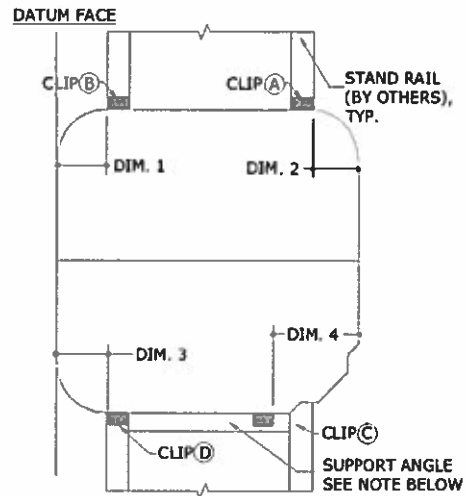
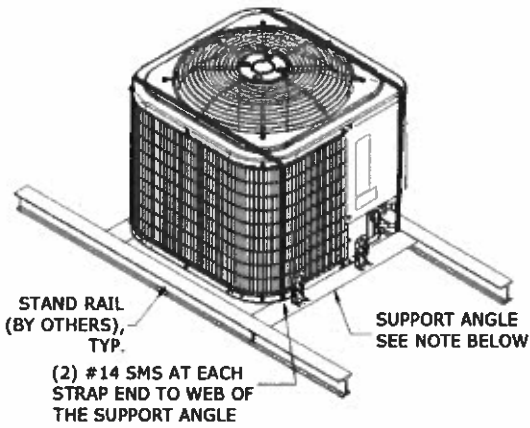

3 MECHANICAL UNIT
N.T.S. FRONT ISOMETRIC

4 TIE-DOWN CLIP LAYOUT
N.T.S. PLAN

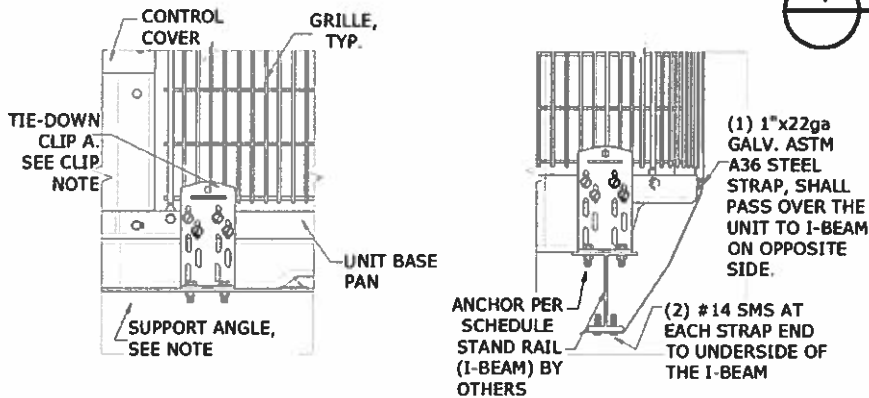

TIE-DOWN CLIP OFFSETS:

DIM. 1	5.00" MAX OFFSET FROM DATUM FACE
DIM. 2	5.00" MAX OFFSET FROM OPPOSITE FACE
DIM. 3	5.00" MAX OFFSET FROM DATUM FACE
DIM. 4	10.00" MAX OFFSET FROM OPPOSITE FACE

5 TIE-DOWN CLIPS & STRAPS
N.T.S. ELEVATION

Note: Miami Tech support angle part number CBCAB30K, CBCAB42K, under NOA #16-0601.01 or equivalent is permitted.

CABINETS & DIMENSIONS

UNIT MODEL	WIDTH (in)	DEPTH (in)	HEIGHT (in)	WEIGHT (lbs)
CH16**024***	35.00	35.00	32.06	172
CH16**030***	35.00	35.00	32.06	207
CH16**036***	35.00	35.00	32.06	215
CH16**042***	35.00	35.00	32.06	233
CH16**048***	35.00	35.00 <td 32.06	238	
CH16**060***	35.00	35.00	45.69	288
CH17**024***	35.00	35.00	38.88	233
CH17**036***	35.00	35.00	38.88	245
CH17**048***	35.00	35.00	38.88	271
CH17**060***	35.00	35.00	45.69	294

UNIT MODEL	WIDTH (in)	DEPTH (in)	HEIGHT (in)	WEIGHT (lbs)
25HP*618****	31.19	31.19	35.50	181
25HP*624****	35.00	35.00	32.06	192
25HP*630****	35.00	35.00	32.06	227
25HP*636****	35.00	35.00	32.06	235
25HP*642****	35.00	35.00	32.06	253
25HP*648****	35.00	35.00	32.06	258
25HP*660****	35.00	35.00	45.69	316
24AP*618	25.75	25.75	35.50	153
24AP*624	31.19	31.19	35.50	174
24AP*630	35.00	35.00	28.68	205
24AP*636	35.00	35.00	28.68	207
24AP*642	35.00	35.00	38.88	264
24AP*648	35.00	35.00	45.69	294
24AP*660	35.00	35.00	45.69	299

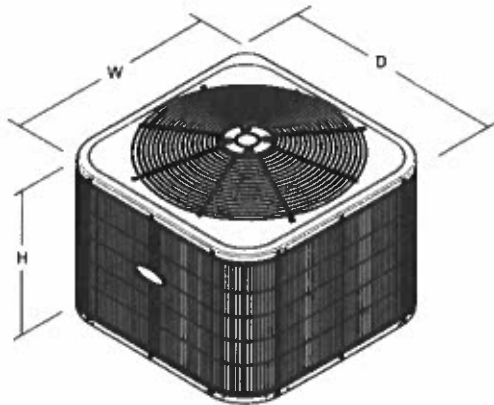

Note: Image is not to scale and is for illustration purposes only. Actual units may differ slightly in appearance. Cabinets CH16

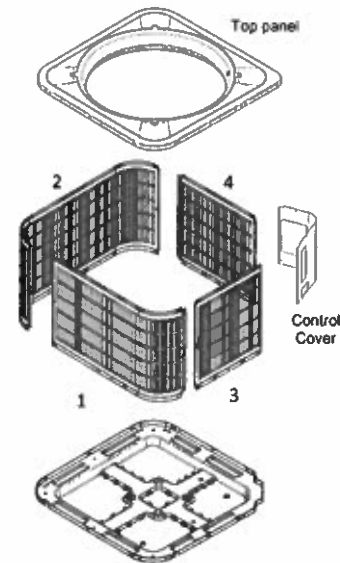

Note: Image is not to scale and is for illustration purposes only. Actual units may differ slightly in appearance. Cabinet 25HP Cabinet 24AP

LIMITATIONS & CONDITIONS OF USE:

Use of this product shall be in strict accordance with this TER as noted herein. The supporting host structure shall be designed to resist all superimposed loads as determined by others on a site specific basis as may be required by the Authority Having Jurisdiction. Host structure conditions which are not accounted for in this product's respective anchor schedule shall be designed on a site-specific basis by a registered professional engineer. No evaluation is offered for the host supporting structure by use of this document; Adjustment factors noted herein and the applicable codes must be considered, where applicable. All supporting components which are permanently installed shall be protected against corrosion, contamination, and other such damage at all times. Fasteners must penetrate the supporting members such that the full length of the threaded portion is embedded within the main member. All anchors, screws, straps, clips, and attachment part can be substituted for equivalent parts, as long as the capacities of the equivalent parts are equal or stronger. Unit integrity is not mandatory; however, this TER certifies regardless. This evaluation does not offer any evaluation to meet large missile impact debris requirements which typically are not required for this type of product. All of the wind resisting exterior panels, individually meet or exceed their capacity to resist the design wind loads as stated in the calculations as required by the FBC (2017). Due to the indeterminate nature of these units, distortion and deflection cannot be accurately evaluated, but with diaphragm action of external components and internal stiffeners, the base unit has the capacity to withstand these forces with individual external parts being contained. Yearly inspections, during equipment maintenance or after a named storm; all screws, cabinet components, clips, anchor, bolts, straps and cables are to be verified by the A/C contractor. All damaged cabinet components, loose, corroded, broken screws or anchor bolts shall be replaced to ensure structural integrity for hurricane wind forces.