

THIS DOCUMENT CONTAINS (4) PAGES: THE FIRST PAGE MUST BEAR AN ORIGINAL SIGNATURE & SEAL OF THE CERTIFYING PE TO BE VALID FOR USE

(Subject to Renew January 1, 2021 or next code cycle change)

EVALUATION SUBJECT: CARRIER SPLIT UNITS
TER-16-3190.3

Florida Building Code Sixth Edition (2017)

REPORT HOLDER:

 CARRIER ENTERPRISE OF FLORIDA
 2000 PARKS OAKS AVE
 ORLANDO, FL 33428 USA
 (954) 247-2003 | FL.CARRIERENTERPRISE.COM

SCOPE OF EVALUATION (compliance with the following codes):
THIS IS A STRUCTURAL (WIND) PERFORMANCE EVALUATION ONLY. NO ELECTRICAL OR TEMPERATURE PERFORMANCE RATINGS OR CERTIFICATIONS ARE OFFERED OR IMPLIED HEREIN.

This Product Evaluation Report is being issued in accordance with the requirements of the Florida Building Code Sixth Edition (2017) per FBC Section 104.11, FMC 301.15, FBC Building Ch. 16, ASCE-7-10, FBC Existing Building sections 707.1, 707.2, FBC Building 1522.2, and FBC Residential M1202.1, M1301.1, FS 471.025, including Broward County Administrative Provisions 107.3.4. The product noted on this report has been tested and/or evaluated as summarized herein.

IN ACCORDANCE WITH THESE CODES EACH OF THESE REPORTS MUST BEAR THE ORIGINAL SIGNATURE & RAISED SEAL OF THE EVALUATING ENGINEER.
SUBSTANTIATING DATA:
• Product Evaluation Documents

Substantiating documentation has been submitted to support this TER and is summarized in the sections that follow.

• Structural Engineering Calculations

Structural engineering calculations have been prepared which evaluate the product based on comparative and/or rational analysis to qualify the following design criteria:

- Maximum allowable unit panel wind pressure connection integrity
- Maximum allowable uplift, sliding, & overturning moment for ground and roof applications

Calculation summary for this TER is provided in the forces summary table. No 33% increase in allowable stress has been used in the design of this product. Microsoft Excel was used to carry out the calculations present in this report.

INSTALLATION:

The product(s) listed in this report shall be installed in strict compliance with this TER & manufacturer-provided model specifications. The product components shall be of the material specified in the manufacturer-provided product specifications. All screws must be installed in accordance with the applicable provisions & anchor manufacturer's published installation instructions.

LIMITATIONS & CONDITIONS OF USE:

Use of this product shall be in strict accordance with this TER as noted herein. See final page for complete limitations and conditions of use.

OPTIONS:

This evaluation is valid for all CARRIER models present in the table located on the final page.

FINISH:

Baked enamel.

NOTE: GRAPHICAL DEPICTIONS IN THIS REPORT ARE FOR ILLUSTRATIVE PURPOSES ONLY. ACTUAL UNITS MAY DIFFER SLIGHTLY IN APPEARANCE.
UNIT CASING MATERIAL:

1.14mm galvanized sheet steel ASTM A653 EDDS cold rolled steel for removable top panel. 1.14mm galvanized sheet steel ASTM A653 EDDS cold rolled steel for base pan. 0.86mm galvanized steel sheet ASTM A653 for side protector panels, secured with #10-16 sheet metal screws into top and base pan.

INSTALLATION:

Shall follow manufacturer specifications as well as the information provided herein.

STRUCTURAL PERFORMANCE:

 Models referenced herein are subject to the following design limitations:
 ASCE7-10 Exposure Category C, Risk II
 Up to and including 175mph (Vult) for up to 200' MRH**. HVHZ***
 Up to and including 170mph (Vult) for up to 250' MRH**. HVHZ***
 Up to and including 200mph (Vult) for up to 200' MRH**. Non-HVHZ***
 Ground or Roof Application per installation instructions
 Mean Roof Height *High Velocity Hurricane Zone

Maximum Rated Wind Pressure:
193psf Lateral, 93psf Uplift (ASD)

Site specific wind analysis may produce alternate limitations provided maximum rated wind pressure is not exceeded.

ABOUT THIS DOCUMENT:

ENGINEER CERTIFIED ORIGINALS, VARIATIONS & HELP CAN BE FOUND BY VISITING THE WEB ADDRESS FOUND HERE BY VISITING THE WEB ADDRESS OR SCANNING THE QR CODE TO THE RIGHT >

 VISIT ENGINEERINGEXPRESS.COM/STORE FOR MORE REPORTS

ecalc.io/1631903

**ORIGINAL SIGNATURE AND RAISED SEAL
OR DIGITAL SEAL REQUIRED TO BE VALID PER CODE:**

August 14, 2019

 Frank L. Bennardo, P.E., SECB Signed by If Checked:
 ENGINEERING EXPRESS® Gordon DiBattisto, PE
 FL PE #0046549 / FLCA #9885 FL PE #82328

NOTICE: IF THIS PAGE DOES NOT CONTAIN AN ORIGINAL SIGNATURE & ENGINEER SEAL: IF THERE IS A DIGITAL SIGNATURE ON PAGE 1, THIS DOCUMENT IS PART OF A DIGITALLY SIGNED FILE, SHALL REMAIN IN DIGITAL FORMAT & PRINTED COPIES OF THIS DOCUMENT ARE NOT CONSIDERED SIGNED AND SEALED. IF THERE IS NO DIGITAL SIGNATURE ON PAGE 1 OR THIS PAGE DOES NOT CONTAIN AN ENGINEER'S ORIGINAL SIGNATURE & SEAL, THIS

Copyright © 2018 Engineering Express® All Rights Reserved

SECTION 2 PRODUCT INSTALLATION

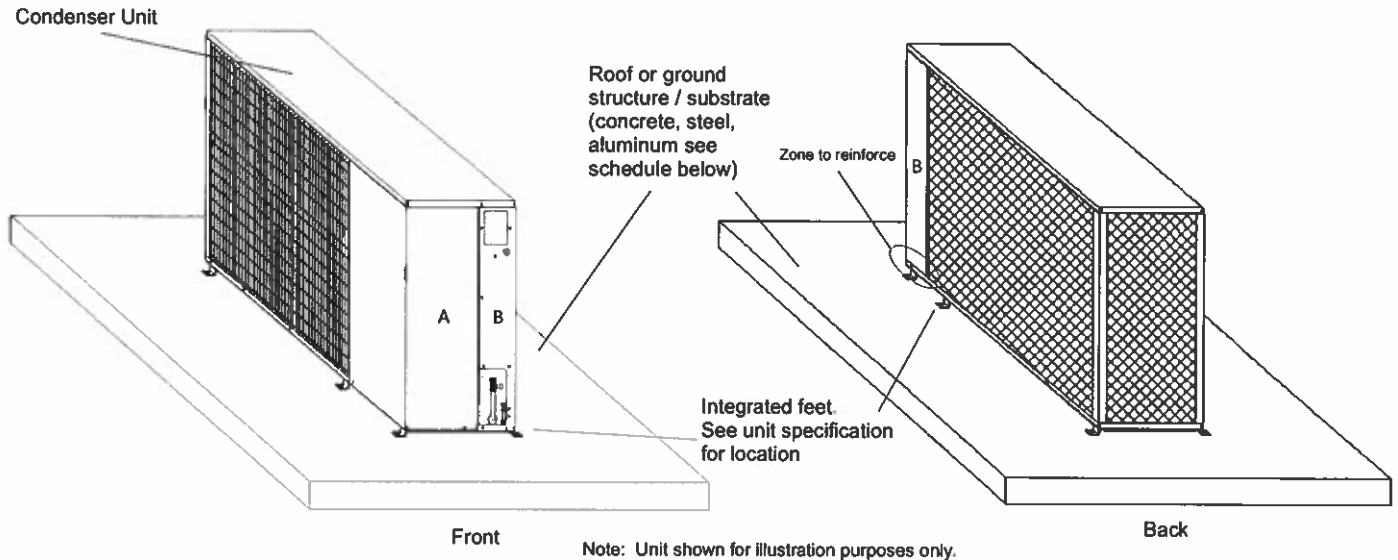

TIE-DOWN STRAP SCHEDULE

Ground or Roof Height*	Tie-down Strap on unit
Ground	NA
Up to 200' (250')	4

- Note:
1. Straps shall be wrapped as shown in details on section 4. The straps shall be tightened to a snug fit around the unit. Straps shall be 1" width and 22ga galvanized metal. For Non-HVHZ, use (4) metal straps, up to 200' MRH. Values shown in table are minimum specified. Using stronger straps per each height is allowed at installer's discretion.
 2. For ground mount use integrated feet.

*The value shown in parentheses indicates the allowable roof height in 170mph conditions. i.e. 60' (80') indicates an allowable roof height of 60' for 175mph or 80' for 170mph Vult.

Tie-down Strap: (for roof applications)

- Minimum edge distance 3" from the unit corners.
- Use a minimum of (2) tie-down straps per side, straps shall be overlaid.

ANCHOR TO HOST STRUCTURE SCHEDULE

Ground or Roof Height*	Anchor Type		
	Concrete 3,000 Psi	1/8" Min A36 Steel	1/8" Min 6061-T6 Aluminum
Ground	A	NA	NA
Up to 200' (250')	NA	B	B

Anchor Types to Host Structure:

- A. - 3/8" Power Fastener Wedge-Bolt OT Anchor embedded 1 1/2" in 3,000 psi concrete. 6" from edge minimum. 6" spacing minimum.
- B. - 3/8" UNC SAE Grade 5 bolt min. 1/2" from edges with nut and washer OD 1"
- NA. - No anchors apply.

IN ALL CONDITIONS IT IS THE RESPONSIBILITY OF THE PERMIT HOLDER TO ENSURE THE HOST STRUCTURE IS CAPABLE OF WITHSTANDING THE RATED GRAVITY, LATERAL, AND UPLIFT FORCES BY SITE-SPECIFIC DESIGN. NO WARRANTY OF ANY KIND, EXPRESSED OR IMPLIED, IS OFFERED BY ENGINEERING EXPRESS AS TO THE INTEGRITY OF THE HOST STRUCTURE TO CARRY DESIGN FORCE LOADS INCURRED BY THIS UNIT.

SECTION 3 SUPPORTING CALCULATIONS & SUMMARY

FORCES SUMMARY

Ground or Roof Height*	Lateral Pressure (Psf)	Uplift Pressure (Psf)	Max Large Side Force (lbs)	Max Large Side Overturn (lbs-in)	Max Large Side Tension (lbs)	Max Short Side Force (lbs)	Max Short Side Overturn (lbs-in)	Max Short Side Tension (lbs)	Max Uplift Force (lbs)
Ground	43.2	0	575.7	12413.9	727.6	220.7	4759.8	107.0	0.0
200' (250')	193.0	93.4	2572.1	55460.4	3250.4	986.2	21265.0	477.9	492.4

Calculations performed according to the information provided by the client. Cabinets were assumed solid (0% porosity) for shear and tension calculation purposes. This forces correspond to the dimension of the biggest unit in this group.

PANEL INTEGRITY SUMMARY

Ground or Roof Height*	Panel Name	Rqrd Wind Pressure (lb/ft ²)	Force on Panel (lbs)	Add'l Screw Qty Needed (pcs)	Additional screws required beyond original manufactured cabinet
Ground	TOP PANEL	0.0	0.0	0	Yes
	PANEL A	43.2	219.5	0	
	PANEL B	43.2	138.4	2	
up to 200' (up to 250')	TOP PANEL	93.4	492.5	0	Yes
	PANEL A	193.0	618.8	0	
	PANEL B	193.0	339.6	2	

*The value shown in parentheses indicates the allowable roof height in 170mph conditions. i.e. 60' (80') indicates an allowable roof height of 60' for 175mph or 80' for 170mph Vult.

SECTION 4 DETAILS

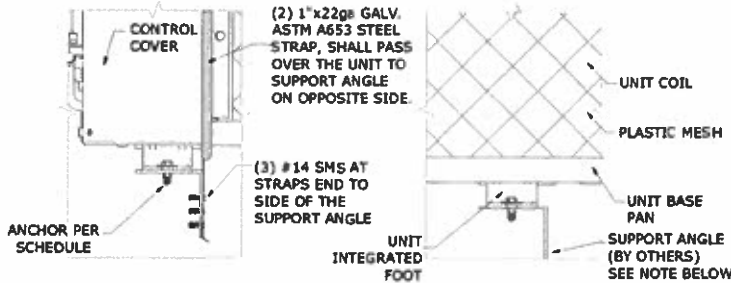
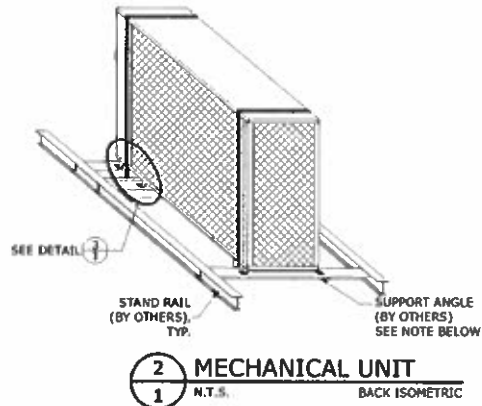
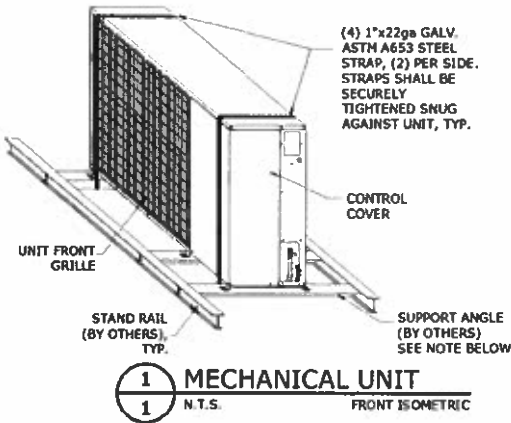

- Note:
- Miami Tech support angle part number CBCAB30K, CBCAB42K, under NOA #16-0601.01 or equivalent is permitted.
 - Louver panels that are not being contained by straps or clips shall be reinforced with #10 410 SS screws; amount of screws required are dictated by panel integrity table. All panels shall be reinforced at the bottom part making sure that the screw joins the panel with the base pan.

CABINETS & DIMENSIONS

Family	Unit Model	Width (in)	Depth (in)	Height (in)
25HH HEAT	25HH-418	36.94	14.56	25.13
	25HH-424	36.94	14.56	31.13
	25HH-430	44.50	17.06	37.13
	25HH-436	44.50	17.06	37.13
	25HH-448	44.50	17.06	43.13
	25HH-460	44.50	17.06	43.13
24AH AC	24AH-418	36.94	14.56	31.13
	24AH-424	36.94	14.56	31.13
	24AH-430	44.50	17.06	37.13
	24AH-436	44.50	17.06	37.13
	24AH-448	44.50	17.06	37.13
	24AH-460	44.50	17.06	43.13

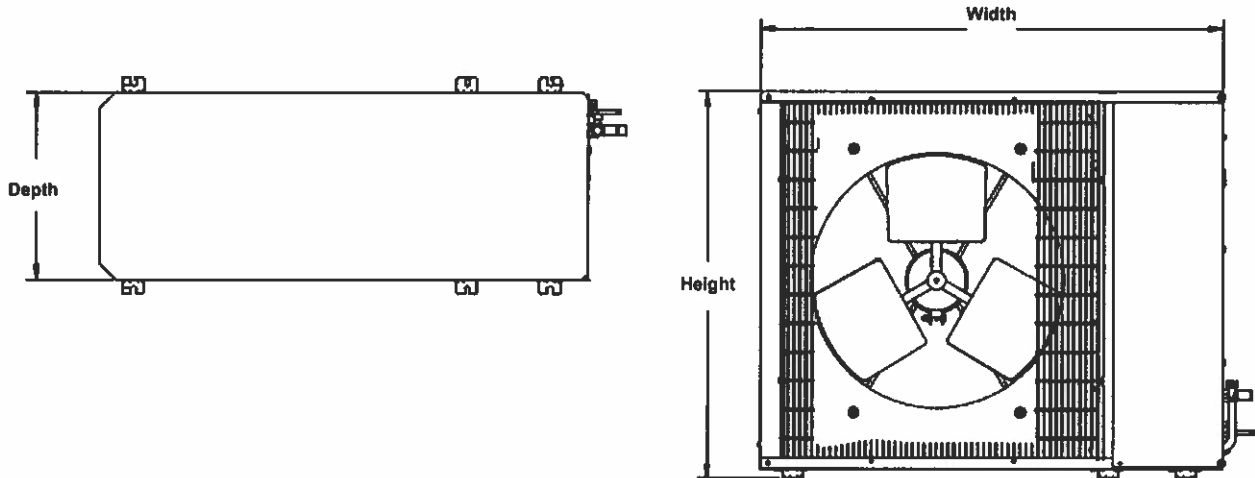

Note: Image is not to scale and is for illustration purposes only
Actual units may differ slightly in appearance.

LIMITATIONS & CONDITIONS OF USE:

Use of this product shall be in strict accordance with this TER as noted herein.
The supporting host structure shall be designed to resist all superimposed loads as determined by others on a site specific basis as may be required by the Authority Having Jurisdiction. Host structure conditions which are not accounted for in this product's respective anchor schedule shall be designed on a site-specific basis by a registered professional engineer. No evaluation is offered for the host supporting structure by use of this document; Adjustment factors noted herein and the applicable codes must be considered, where applicable. All supporting components which are permanently installed shall be protected against corrosion, contamination, and other such damage at all times. Fasteners must penetrate the supporting members such that the full length of the threaded portion is embedded within the main member. All anchors, screws, straps, clips, and attachment part can be substituted for equivalent parts, as long as the capacities of the equivalent parts are equal or stronger. This evaluation does not offer any evaluation to meet large missile impact debris requirements which typically are not required for this type of product.
All of the wind resisting exterior panels, individually meet or exceed their capacity to resist the design wind loads as stated in the calculations as required by the Florida Building Code Sixth Edition (2017). Due to the indeterminate nature of these units, distortion and deflection cannot be accurately evaluated, but with diaphragm action of external components and internal stiffeners, the base unit has the capacity to withstand these forces with individual external parts being contained. Yearly inspections, during equipment maintenance or after a named storm; all screws, cabinet components, clips, anchor, bolts, straps and cables are to be verified by the A/C contractor. All damaged cabinet components, loose, corroded, broken screws or anchor bolts shall be replaced to ensure structural integrity for hurricane wind forces