

160 SW 12TH AVE SUITE 106, DEERFIELD BEACH, FL 33442
(954) 354-0660 | ENGINEERINGEXPRESS.COM**THIS DOCUMENT CONTAINS (7) PAGES: THE FIRST PAGE MUST BEAR AN ORIGINAL SIGNATURE & SEAL OF THE CERTIFYING PE TO BE VALID FOR USE**

(Subject to Renew January 1, 2021 or next code cycle change)

EVALUATION SUBJECT: BRYANT PACKAGE UNITS**TER-16-3190.14****REPORT HOLDER:**BRYANT HEATING AND COOLING
2000 PARKS OAKS AVE
ORLANDO, FL 33428 USA
(954) 247-2003 | FL. BRYANT.COM

Florida Building Code Sixth Edition (2017)

**SCOPE OF EVALUATION (compliance with the following codes):****THIS IS A STRUCTURAL (WIND) PERFORMANCE EVALUATION ONLY. NO ELECTRICAL OR TEMPERATURE PERFORMANCE RATINGS OR CERTIFICATIONS ARE OFFERED OR IMPLIED HEREIN.**

This Product Evaluation Report is being issued in accordance with the requirements of the Florida Building Code Sixth Edition (2017) per FBC Section 104.11, FMC 301.15, FBC Building Ch. 16, ASCE-7-10, FBC Existing Building sections 707.1, 707.2, FBC Building 1522.2, and FBC Residential M1202.1, M1301.1, FS 471.025, including Broward County Administrative Provisions 107.3.4. The product noted on this report has been tested and/or evaluated as summarized herein.

IN ACCORDANCE WITH THESE CODES EACH OF THESE REPORTS MUST BEAR THE ORIGINAL SIGNATURE & RAISED SEAL OF THE EVALUATING ENGINEER.**SUBSTANTIATING DATA:****• Product Evaluation Documents**

Substantiating documentation has been submitted to support this TER and is summarized in the sections that follow.

• Structural Engineering Calculations

Structural engineering calculations have been prepared which evaluate the product based on comparative and/or rational analysis to qualify the following design criteria:

- Maximum allowable unit panel wind pressure connection integrity
- Maximum allowable uplift, sliding, & overturning moment for ground and roof applications

Calculation summary for this TER is provided in the forces summary table. No 33% increase in allowable stress has been used in the design of this product. Microsoft Excel was used to carry out the calculations present in this report.

INSTALLATION:

The product(s) listed in this report shall be installed in strict compliance with this TER & manufacturer-provided model specifications.

The product components shall be of the material specified in the manufacturer-provided product specifications. All screws must be installed in accordance with the applicable provisions & anchor manufacturer's published installation instructions.

LIMITATIONS & CONDITIONS OF USE:

Use of this product shall be in strict accordance with this TER as noted herein. See final page for complete limitations and conditions of use.

OPTIONS:

This evaluation is valid for all BRYANT model families PA4Z, PH4Z, 604D, 707C-B, 607C-B, 707C-C, 607C-C, 707E, 607E, capacities 24, 30, 36, 42, 48, 60. Unit Model example: 607C-C48.

FINISH:

Baked enamel.

NOTE: GRAPHICAL DEPICTIONS IN THIS REPORT ARE FOR ILLUSTRATIVE PURPOSES ONLY AND MAY DIFFER IN APPEARANCE**UNIT CASING MATERIAL:**

0.86mm galvanized sheet steel ASTM A653 EDDS cold rolled steel for removable top panel. 1.14mm galvanized sheet steel ASTM A653 EDDS cold rolled steel for base pan. 0.86mm galvanized steel sheet ASTM A653 for side protector louvers and panels, secured with #10-16 sheet metal screws into top and base pan.

INSTALLATION:

Shall follow manufacturer specifications as well as the information provided herein.

STRUCTURAL PERFORMANCE:

Models referenced herein are subject to the following design limitations: ASCE7-10 Exposure Category C, Risk II

Up to and including 175mph (Vult) for up to 200' MRH**. HVHZ***

Up to and including 170mph (Vult) for up to 250' MRH**. HVHZ***

Up to and including 200mph (Vult) for up to 56' MRH**. Non-HVHZ***

Ground or Roof Application per installation instructions

Mean Roof Height *High Velocity Hurricane Zone

Maximum Rated Wind Pressure:

193psf Lateral, 93psf Uplift (ASD)

Site specific wind analysis may produce alternate limitations provided maximum rated wind pressure is not exceeded.

Find this report and all the help you need at

EngineeringExpress.com/Carrier**ABOUT THIS DOCUMENT:**

ENGINEER CERTIFIED ORIGINALS, VARIATIONS & HELP CAN BE FOUND BY VISITING THE WEB ADDRESS FOUND HERE BY VISITING THE WEB ADDRESS OR SCANNING THE QR CODE TO THE RIGHT >

VISIT ENGINEERINGEXPRESS.COM/STORE FOR MORE REPORTS ECALC.IO/163190.14**ORIGINAL SIGNATURE AND RAISED SEAL
OR DIGITAL SEAL REQUIRED TO BE VALID PER CODE:**

July 23, 2019

Frank L. Bennardo, P.E., BECB® Signed by If Checked:
ENGINEERING EXPRESS® Gordon DiBattisto, PE
FL PE #0046549 FLCA #9885 FL PE #82328**NOTICE: IF THIS PAGE DOES NOT CONTAIN AN ORIGINAL SIGNATURE & ENGINEER SEAL: IF THERE IS A DIGITAL SIGNATURE ON PAGE 1, THIS DOCUMENT IS PART OF A DIGITALLY SIGNED FILE, SHALL REMAIN IN DIGITAL FORMAT & PRINTED COPIES OF THIS DOCUMENT ARE NOT CONSIDERED SIGNED AND SEALED. IF THERE IS NO DIGITAL SIGNATURE ON PAGE 1 OR THIS PAGE DOES NOT CONTAIN AN ENGINEER'S ORIGINAL SIGNATURE & SEAL, THIS**

Copyright © Engineering Express®. All Rights Reserved

SECTION 2 PRODUCT GROUND INSTALLATION

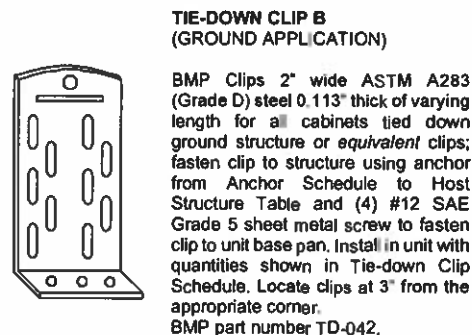
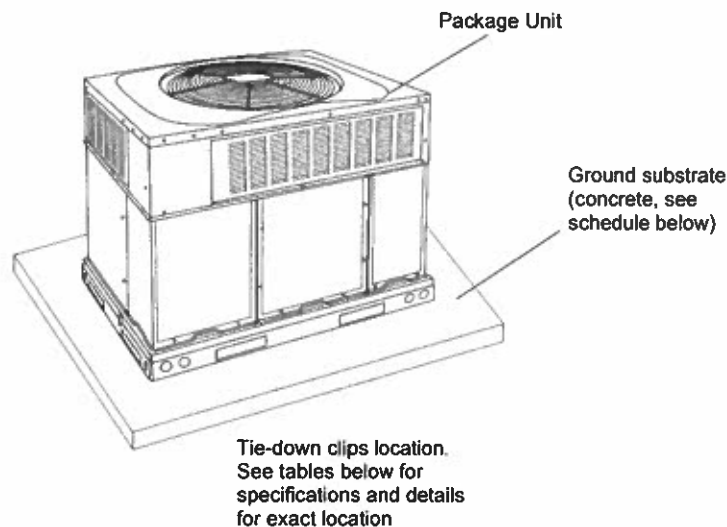

TIE-DOWN CLIP SCHEDULE

Unit Models ⁺	Tie-down Clips A	Tie-down Clips B
Table 1	6	6
Table 2	NA	6

+ See tables on last page for cabinet classification.

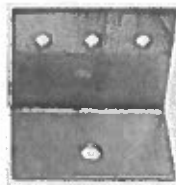

TIE-DOWN CLIP A
(GROUND APPLICATION)

Tie-down clips 3.25" wide ASTM A653 steel 16ga cabinets tied down to a ground structure (concrete slab); fasten clip to structure using (1) anchor from Anchor Schedule to Host Structure Table (A) and (3) #14 SAE Grade 2 self-drilling screws to fasten clip to unit base pan. Install in unit with quantities shown in Tie-down Clip Schedule. Locate clips at 3" from the appropriate corner, equally spaced. Kit # CBTDC-KGR

ANCHOR TO HOST STRUCTURE SCHEDULE

Unit Models ⁺	Clip Type	Anchor Type
		Concrete 3,000 Psi
Table 1	Type A	1
	Type B	2
Table 2	Type A	NA
	Type B	2

Anchor Types to Host Structure:

1. - 3/8" ITW RED HEAD Trubolt wedge. Into 3,000 psi concrete minimum, edge distance 2-5/8" minimum and spacing 5-1/4" minimum.
 2. - 1/4" ELCO ULTRACON SS4 Anchor embedded 1 3/4" in 3,000 psi concrete. 2 1/2" from edge minimum.
- NA. - No anchors apply.

PANEL INTEGRITY

Unit Models	Ground or Roof Height*	Panel Name	Additional Screws Required (pcs)	Additional reinforcement required beyond original manufacturing	Unit Models	Additional Screws Required (pcs)	Additional reinforcement required beyond original manufacturing
Table 1	Ground	TOP PANEL	-	Yes	Table 2	-	No
		PANEL A	-				
		PANEL B	-				
		PANEL C	-				
		PANEL D	-				
		PANEL E	-				
		PANEL F	-				
PANEL G	SEE DETAIL						

IN ALL CONDITIONS IT IS THE RESPONSIBILITY OF THE PERMIT HOLDER TO ENSURE THE HOST STRUCTURE IS CAPABLE OF WITHSTANDING THE RATED GRAVITY, LATERAL, AND UPLIFT FORCES BY SITE-SPECIFIC DESIGN. NO WARRANTY OF ANY KIND, EXPRESSED OR IMPLIED, IS OFFERED BY ENGINEERING EXPRESS AS TO THE INTEGRITY OF THE HOST STRUCTURE TO CARRY DESIGN FORCE LOADS INCURRED BY THIS UNIT.

TIE-DOWN CLIP LAYOUT

FAMILIES: 604D, 707C-B, 607C-B, 707C-C, 607C-C, 707E, 607E, 577C.

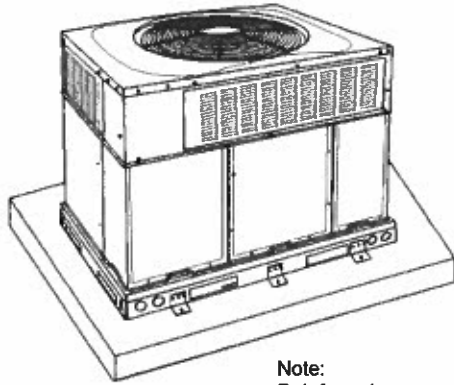

Note:
Reinforce louvers per detail 7

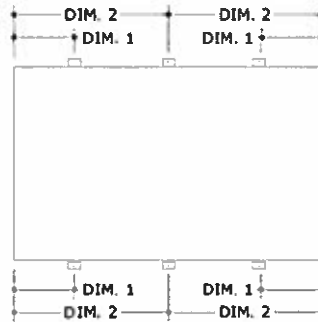

TIE-DOWN CLIP LAYOUT

TIE-DOWN CLIP LOCATIONS

DIM. 1	10" MAX
DIM. 2	ON CENTER (LONG SIDE OF UNIT)

FAMILIES: 50ZPC, 50ZHC.

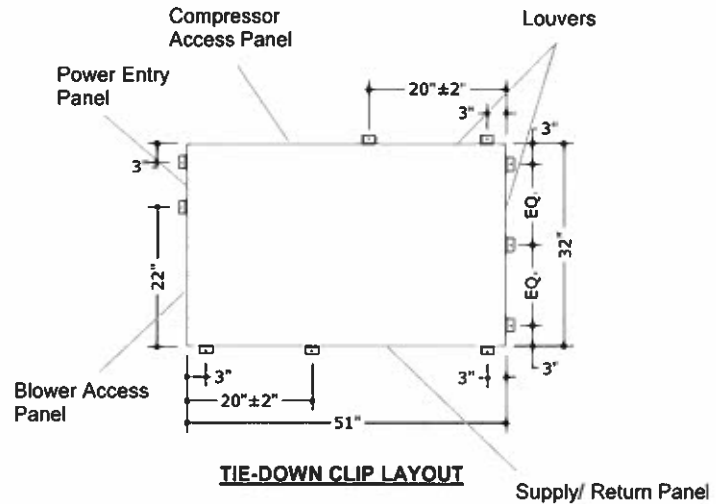
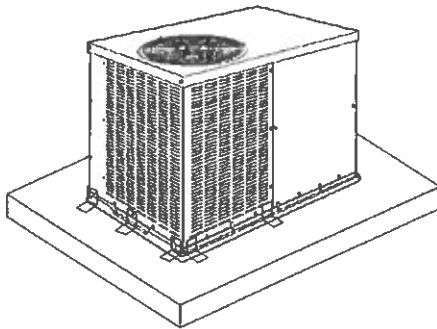

TIE-DOWN CLIP LAYOUT

Note:
Compressor Access panel and Blower Access Panel shall not be blocked with Tie-down Clips

FORCES SUMMARY

Unit Models	Lateral Pressure (Psf)	Uplift Pressure (Psf)	Large Side Force (lbs)	Large Side Overturn (lbs-in)	Large Side Tension (lbs)	Small Side Force (lbs)	Small Side Overturn (lbs-in)	Small Side Tension (lbs)	Max Uplift Force (lbs)
Table 1	42.4	42.4	759.0	29218.7	690.5	683.0	28084.4	663.7	586.0
Table 2	42.4	42.4	619.0	17489.3	546.5	388.0	15300.7	478.0	471.0

Note:

- Calculations performed according to the information provided by the client. Cabinets were assumed solid (0% porosity) for shear and tension calculation purposes.
- Screw quantities were checked to reinforce unit panels as needed. They shall be spaced evenly throughout the panel bottom part, validating that the screw joins the panel with the supporting element. Screw sizes, quantities on panel, and panel characteristics are according to client's description.
- Additional screw shall be at least #10 SS 410.
- For panel G, strap tie shall be no thinner than 16ga (This note applies just for unit models in table 1).
- Installer shall insulate dissimilar metals.
- Units on details, may differ from actual units in appearance.
- Details apply for clip type A & clip type B, with model unit limitation (see Table 2 last page).
- Slab dimension by others.

SECTION 3 PRODUCT ROOF INSTALLATION

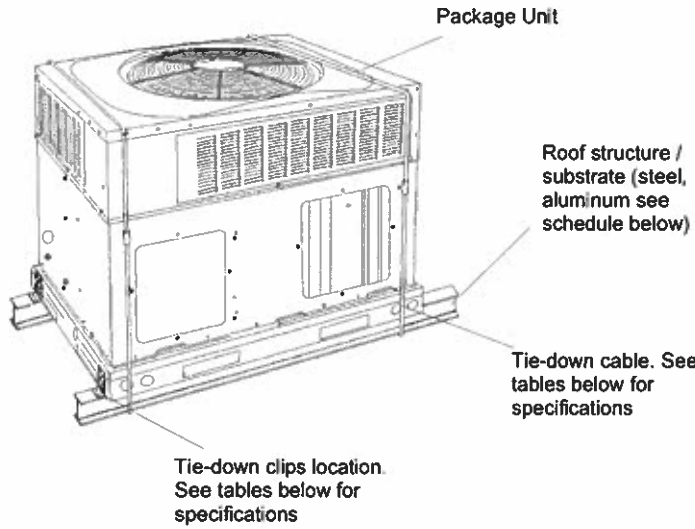

TIE-DOWN CLIP (ROOF APPLICATION)

BMP Clips 2" wide ASTM A283 (Grade D) steel 0.113" thick of varying length for all cabinets tied down to a roof structure (roof stand) or equivalent clips; fasten clip to structure using (2) anchor from Anchor Schedule to Host Structure Table and (4) #12 SAE Grade 5 sheet metal screw to fasten clip to unit base pan. Install in unit with quantities shown in Tie-down Strap & Clip Schedule. Locate clips at 2" min from the appropriate corner. BMP part number TD-042.

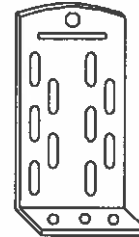

TIE-DOWN CABLE & CLIP SCHEDULE

Unit Models ⁺	Roof Height [*]	Tie-down Cable	Cable Diameter	Cable WLL (lbs)	Screw Curb/ Unit Rail	Tie-down Clips
Table 1	Up to 200' (250')	2	1/4"	1220	(1) B @ 2-1/8"	4

* The value shown in parentheses indicates the allowable roof height in 170mph conditions. i.e. 200' (250') indicates an allowable roof height of 200' for 175mph or 250' for 170mph Vult.
 + See tables on last page for cabinet classification.

Tie-down Cable Type: (for roof applications)

- 1.- 7x7 Galvanized cable for industrial application or any cable configuration that meets or exceeds WLL (Working Load Limit) specified.
- 2.- Minimum edge distance 3" from the unit corners.
- 3.- Tie-down cable shall be wrapped around the unit and roof stand rail, and shall be tightened to a snug fit using the turnbuckle.
- 4.- Provide two cables per unit and one turnbuckle per cable, installer shall verify that the capacity of the turn buckle meets or exceeds cable capacity.
- 5.- Neoprene pad shall be placed between the cable and the cabinet to prevent distortion.

ANCHOR TO HOST STRUCTURE SCHEDULE

Unit Models ⁺	Roof Height [*]	Anchor Type		
		1/8" Min A36 Steel	1/8" Min 6061-T6 Aluminum	A653 Steel Curb
Table 1	Up to 200' (250')	A	A	B

Anchor Types to Host Structure:

- A. - 1/4" SAE Grade 5 screw minimum 1/2" from edges with nut and washer OD 0.75"
- B. - #12 Stainless Steel 410, Self-drilling screw, no less than 1/2" long.

Notes:
 1.- Minimum steel curb thickness 18ga.

PANEL INTEGRITY

Unit Models	Roof Height [*]	Panel Name	Additional Screws Required (pcs)	Additional reinforcement required beyond original manufacturing
Table 1	Up to 200' (250')	TOP PANEL	0	Yes
		PANEL A	2	
		PANEL B	0	
		PANEL C	4	
		PANEL D	4	
		PANEL E	0	
		PANEL F	2	
PANEL G	See detail 8			

- Notes:
1. Calculations performed according to the information provided by the client. Cabinets were assumed solid (0% porosity) for shear and tension calculation purposes.
 2. Screw quantities were checked to reinforce unit panels as needed. They shall be spaced evenly throughout the panel bottom part, validating that the screw joins the panel with the supporting element (base panel, for more details see last page). Screw sizes, quantities on panel, and panel characteristics are according to client's description.
 3. Additional screws shall be at least #10 SS 410.
 4. For panel G, strap tie shall be no less than 16ga.
 5. Installer shall insulate dissimilar metals.

TIE-DOWN CABLE AND CLIP LAYOUT

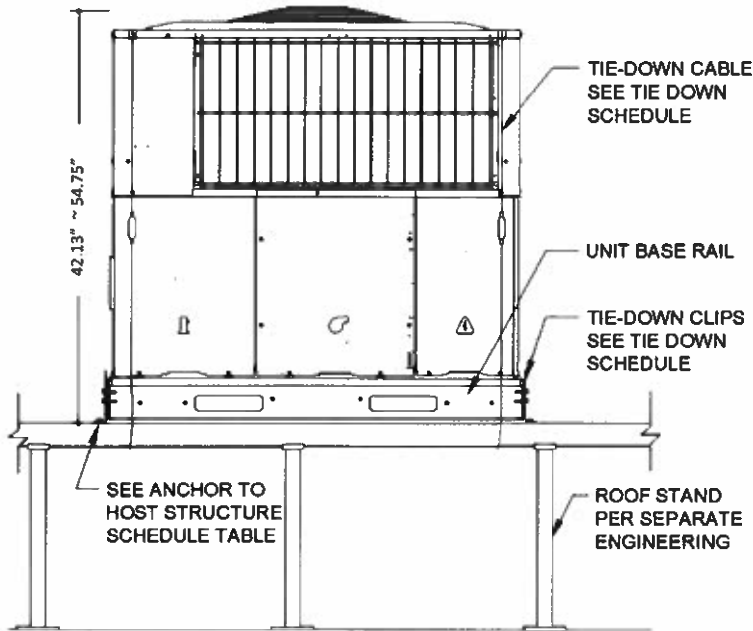

1 TYPICAL ROOF MOUNT ON STAND
SCALE: N.T.S. ELEVATION VIEW

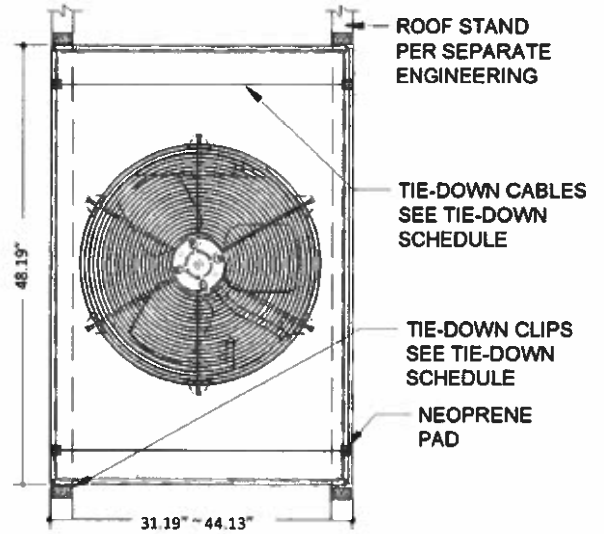

2 TYPICAL ROOF MOUNT ON STAND
SCALE: N.T.S. PLAN VIEW

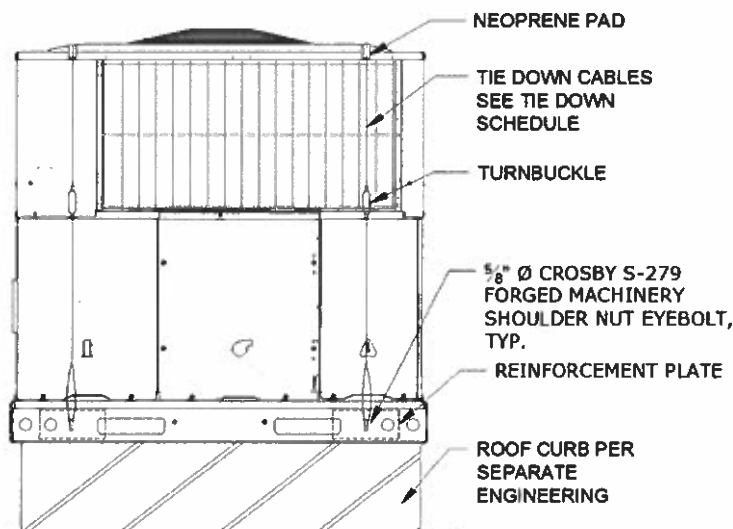

3 TYPICAL ROOF MOUNT ON CURB
SCALE: N.T.S. ELEVATION VIEW

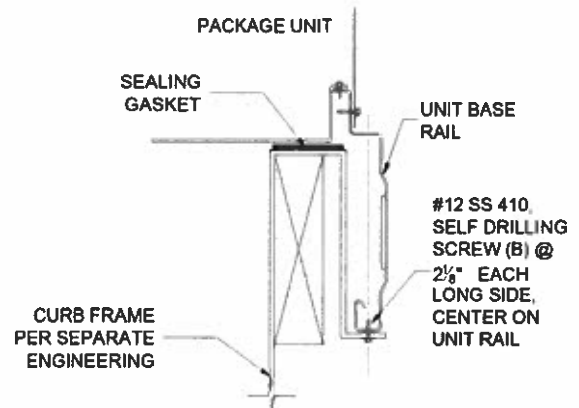

4 ROOF MOUNT ON CURB
SCALE: N.T.S. DETAIL VIEW

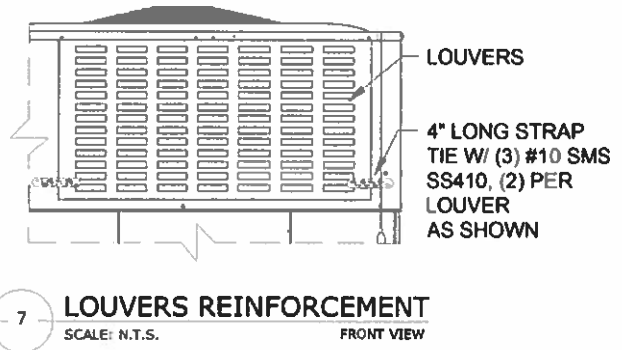
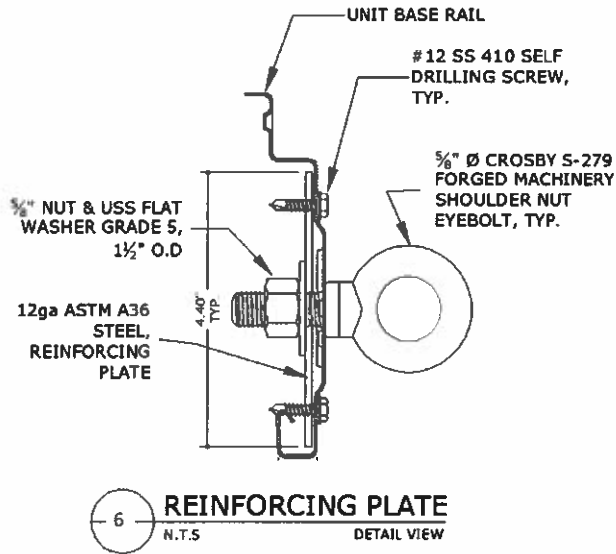
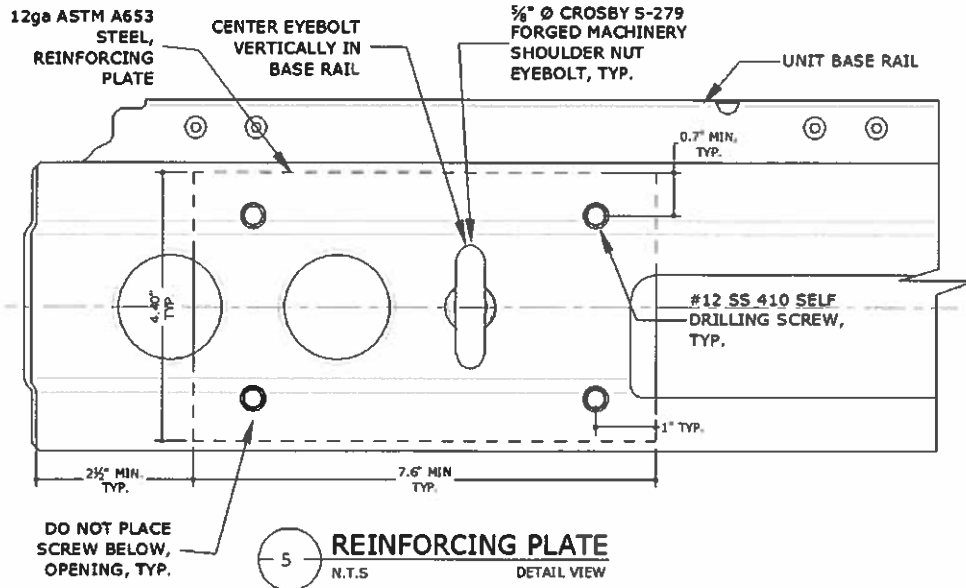

FORCES SUMMARY

Unit Models	Roof Height*	Lateral Pressure (Psf)	Uplift Pressure (Psf)	Large Side Force (lbs)	Large Side Overturn (lbs-in)	Large Side Tension (lbs)	Small Side Force (lbs)	Small Side Overturn (lbs-in)	Small Side Tension (lbs)	Max Uplift Force (lbs)
Table 1	Up to 200' (250')	193.1	93.4	3450.0	117787.7	2783.8	3106.0	110955.0	2360.7	1290.0

SECTION 4 UNIT FAMILIES, DIMENSIONS & PANEL LOCATION

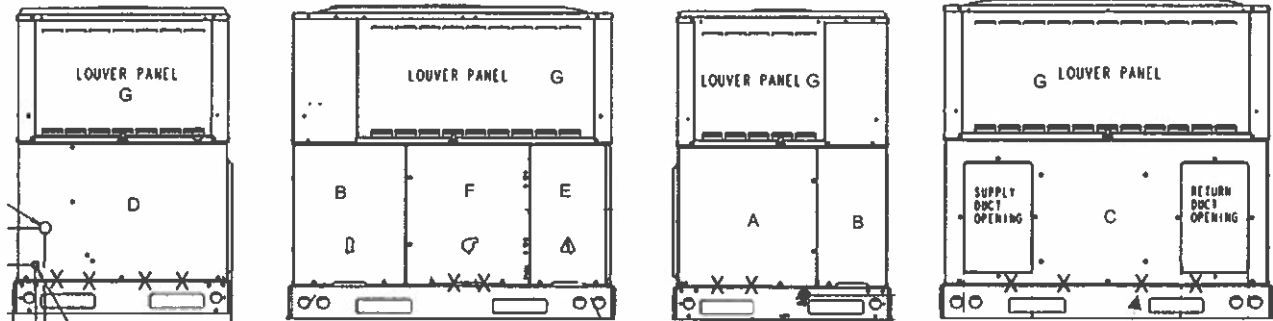

TABLE 1
 FAMILIES: 604D, 707C-B, 607C-B, 707C-C, 607C-C, 707E, 607E, 577C.
 CAPACITIES: 24, 30, 36, 42, 48, 60
 UNITS DIMENSIONS:
 WIDTH: 31.19" ~ 44.13"
 DEPTH: 48.19"
 HEIGHT: 42.13" ~ 54.75"
 WEIGHT: 288 lbs. ~ 506 lbs.

Recommended reinforcing screw location. See panel integrity for quantities per panel.

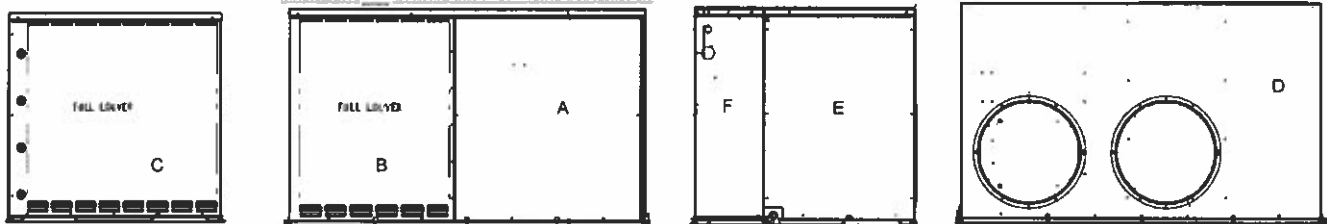

TABLE 2
 FAMILIES: PA4Z, PH4Z.
 CAPACITIES: 24, 30, 36, 42, 48, 60
 UNITS DIMENSIONS:
 WIDTH: 32.00"
 DEPTH: 51.00"
 HEIGHT: 30.13" ~ 42.13"
 WEIGHT: 230 lbs. ~ 425 lbs.
 CABINET NOTE: PA4Z & PH4Z are not suitable for Clip A, Rail, or Roof Curb installations. Approved for Concrete Slab and Ground Mounting designs.

LIMITATIONS & CONDITIONS OF USE:

Use of this product shall be in strict accordance with this TER as noted herein.
 The supporting host structure shall be designed to resist all superimposed loads as determined by others on a site specific basis as may be required by the Authority Having Jurisdiction. Host structure conditions which are not accounted for in this product's respective anchor schedule shall be designed on a site-specific basis by a registered professional engineer. No evaluation is offered for the host supporting structure by use of this document; Adjustment factors noted herein and the applicable codes must be considered, where applicable. All supporting components which are permanently installed shall be protected against corrosion, contamination, and other such damage at all times. Fasteners must penetrate the supporting members such that the full length of the threaded portion is embedded within the main member. All anchors, screws, straps, clips, and attachment part can be substituted for equivalent parts, as long as the capacities of the equivalent parts are equal or stronger. This evaluation does not offer any evaluation to meet large missile impact debris requirements which typically are not required for this type of product.
 All of the wind resisting exterior panels, individually meet or exceed their capacity to resist the design wind loads as stated in the calculations as required by the Florida Building Code Sixth Edition (2017). Due to the indeterminate nature of these units, distortion and deflection cannot be accurately evaluated, but with diaphragm action of external components and internal stiffeners, the base unit has the capacity to withstand these forces with individual external parts being contained. Yearly inspections, during equipment maintenance or after a named storm; all screws, cabinet components, clips, anchor, bolts, straps and cables are to be verified by the A/C contractor. All damaged cabinet components, loose, corroded, broken screws or anchor bolts shall be replaced to ensure structural integrity for hurricane wind forces.