

Installation Instructions



A07049

Programmable Control



A07048

Non-Programmable Control



Designed and Assembled in the U.S.A.

NOTE: Read the entire instruction manual before starting the installation.

US patents: US7287709 B2, US20080147242 A1, USD582800 SI, US20060165149 A1, US6956463 B2.

TABLE OF CONTENTS

	PAGE
SAFETY CONSIDERATIONS	1
INTRODUCTION	2
INSTALLATION CONSIDERATIONS	3
INSTALLATION	6
SYSTEM START-UP AND CHECKOUT	39
OPERATIONAL INFORMATION	42
TROUBLESHOOTING	46
WIRING DIAGRAMS	50
THERMOSTAT CONFIGURATION RECORD	59

SAFETY CONSIDERATIONS

Read and follow manufacturer instructions carefully. Follow all local electrical codes during installation. All wiring must conform to local and national electrical codes. Improper wiring or installation may damage AC/HP Control.

Recognize safety information. This is the safety-alert symbol . When you see this symbol on the equipment and in the instruction manual, be alert to the potential for personal injury.

Understand the signal words **DANGER**, **WARNING**, and **CAUTION**. These words are used with the safety-alert symbol. **DANGER** identifies the most serious hazards which will result in severe personal injury or death. **WARNING** signifies a hazard which could result in personal injury or death. **CAUTION** is used to identify unsafe practices which may result in minor personal injury or product and property damage. **NOTE** is used to highlight suggestions which will result in enhanced installation, reliability, or operation.

INTRODUCTION

Carrier's 7-day, 5/2-day, 1-day programmable and non-programmable Performance Series Thermostat Control is a wall-mounted, low-voltage temperature control in either a single unit or a two-piece unit. In two-piece configuration, the relays are located near the equipment and a two-wire connection is used between the Display Module and the Equipment Control Module. Single-piece installation requires more wiring and results in a higher profile. The Edge™ Thermostat has no need for batteries to store user-configured settings in memory. During power loss its internal memory saves settings for unlimited time, and the clock continues to run for at least 24 hours. An extension of Carrier's proven line of thermostats; it provides separate setpoints for heating and cooling.

In the Edge Thermostat Control programmable configuration, different heating and cooling setpoints and times are programmable for 4 periods per day or 2 periods per day. Programming can be done for 7 days per week, 5/2 days per week, or 1 day. The programmable Thermostat Control can also be user configured as a non-programmable Thermostat Control.

The non-programmable Thermostat Control features Touch 'N' Go™ settings for quick and easy temperature change without complicated programming schedules. And, its Touch 'N' Go technology enables the user to switch between three different user-configurable settings through intuitive buttons located just below the display.

INSTALLATION CONSIDERATIONS

Power

This control is powered by 24VAC only. It requires 24VAC (Rh and/or Rc and C terminals) of the low-voltage transformer to be connected to it for proper operation. It will not operate without these 2 connections. Rh and Rc are connected via PCB breakout jumper. See Fig. 1. For applications using two 24VAC transformers, one in the indoor unit and one in the outdoor unit, connect the common from each to the C terminal. Connect R from the indoor unit to the Rh terminal. Connect R from the outdoor unit to the Rc terminal. Then, break jumper on the circuit board. The W signal is taken from the Rh power and the G signal is taken from the Rc power. If the thermostat has been installed in a two-transformer application that is later changed to a single-transformer installation, installer must install a field supplied jumper between Rc and Rh. Depending on the installation, up to 14 wires may be required. Installation as two-piece unit is recommended. Only 2 wires are required for connection between Display Module and Equipment Control Module. These two wires (V+ and Vg) do not provide ordinary 24VAC. They carry a combination of power and communications data that is unique to these products.



A07052

Fig. 1 - PCB Breakout Jumper

Models

There are programmable and non-programmable models for all applications. They can be configured for AC or HP installations, allowing it to be used in place of all Carrier thermostats. Programmable thermostats may be configured as non-programmable if user desires.

Outdoor Temperature Sensor

The outdoor air temperature sensor is not included with the AC/HP Control. It is available as an accessory, part number TSTATCCSEN01-B. Optimum performance is obtained when an outdoor temperature sensor is used with the AC/HP Control. Plan installation so that 2 wires can be run from Equipment Control Module to an outdoor location, preferably on the north side of the house or refer to Installation Instructions included with the outdoor temperature sensor for simplified connection. Sensor can be mounted to outdoor unit and existing dedicated sensor wires may be used for its connection. Details are provided in sensor instructions.

Remote Indoor Temperature Sensor

A remote temperature sensor may be used with the programmable heat pump and programmable air conditioner thermostats where it is desirable to install the thermostat in a limited access location while measuring the temperature in the living space. The remote room sensor may be used as a stand alone or average with local sensor.

Two-Piece Thermostat Configuration

The Performance Series AC/HP Control can be installed in one of two configurations. The control may be installed as a single-piece thermostat or it may be split into two pieces and mounted in separate locations. As a single-piece unit, all required wiring must be brought to the Equipment Control Module for connection to the terminal strip. In two-piece configuration, the Display Module can be mounted in the living space while the Equipment Control Module may be mounted near the indoor furnace or fan coil. Connection from the display to the Equipment Control Module requires only two wires. All other control wires are connected to the Equipment Control Module from the HVAC equipment. This configuration results in a slimmer display and locates the Equipment Control Module containing the switching relays away from the main living space where relay clicking will not be heard.

The model numbers on the Display Module and the Equipment Control Module (ECM) must match or unpredictable results may occur.

Two-wire pigtail replacement part number is TX-2WR-05.

Wiring

For all wiring applications, use 22 AWG or larger wire. Continuous wire lengths over 100 ft. (30.5 m) should use 20 AWG or larger. Wire lengths are not to exceed 250 ft. (76 m) per run.

INSTALLATION



CAUTION

UNIT DAMAGE HAZARD

Failure to follow the recommended wiring practices could result in damage to the wall control and personal property.

Improper wiring or installation may damage AC/HP Control. Check to make sure wiring is correct before proceeding with installation or turning on power.

Installation Notes:

- No part of the control should be installed directly outdoors or in a cabinet outdoors.
- Never remove the thermostat board from the plastic housing. Doing so could warp and damage the components on the board.
- The control assembly should be mounted before wires are attached.
- During thermostat installation, provide sufficient excess wiring behind the mounting plate. Coil the wiring, creating a service loop, and place in mounting box or behind the wall to remove strain against the terminal strip. See Fig. 2.

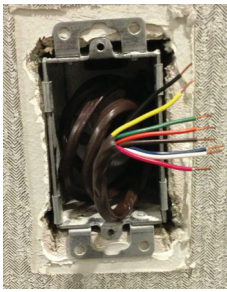

Fig. 2 - Coil Excess Wiring

A13295

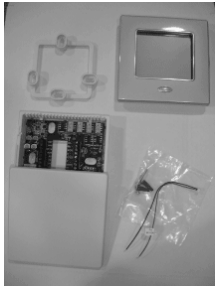

Fig. 3 - TP-PAC / TP-PHP Carton Contents

A07754

Carton contains the following components. See Fig. 3 for programmable models or Fig. 4 for non-programmable models.

1. Display Module
2. Stand-off for Equipment Control Module
3. Screws and pig tail
4. Equipment Control Module

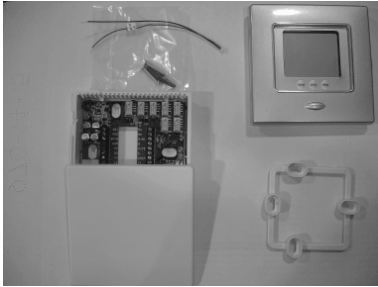

Fig. 4 - TP-NAC / TP-NHP Carton Contents

A07755

1. Display Module
2. Stand-off for Equipment Control Module
3. Screws and pig tail
4. Equipment Control Module

AC/HP Control Location

AC/HP Control should be mounted:

- Approximately 5 ft (1.5m) from floor.

- Close to or in a frequently used room, preferably on an inside partitioning wall.
- On a section of wall without pipes or duct work.

AC/HP Control should NOT be mounted:

- Close to a window, on an outside wall, or next to a door leading to the outside.
- Exposed to direct light or heat from a lamp, sun, fireplace, or other temperature-radiating objects which could cause a false reading.
- Close to or in direct airflow from supply registers and return-air registers.
- In areas with poor air circulation, such as behind a door or in an alcove.

Installer should determine whether control will be installed as single-piece or two-piece. In single-piece configuration, as many as 14 wires may need to run to wall mounting location for connection to the control. In two-piece configuration, the Display Module and Equipment Control Module are connected by two wires.

Install AC/HP Control



WARNING

ELECTRICAL OPERATION HAZARD

Failure to follow this warning could result in personal injury or death.

Before installing AC/HP Control, turn off all power to equipment.
There may be more than 1 power disconnect.



CAUTION

UNIT DAMAGE HAZARD

Failure to follow this caution may result in equipment damage or improper operation.

Improper wiring or installation may damage AC/HP Control. Check to make sure wiring is correct before proceeding with installation or turning on power.

1. Turn off all power to equipment.
2. If an existing thermostat is being replaced
 - a. Remove existing thermostat from wall.
 - b. Disconnect wires from existing thermostat, 1 at a time.
 - c. As each wire is disconnected, record wire color and terminal marking.
 - d. Discard or recycle old thermostat.



CAUTION

ENVIRONMENTAL HAZARD

Failure to follow this caution may result in environmental damage.

Mercury is a hazardous waste. Federal regulations require that Mercury be disposed of properly.

Two-Piece Installation

The following steps should be followed for the installation of the two-piece configuration.

NOTE: The 2-wire pigtail is not intended to support the weight of the User Interface. Do not hang the User Interface from the equipment Control Module screw terminals.

1. Remove mounting plate from back of Display Module by pressing the two tabs on the bottom edge and pulling away. See Fig. 5 and 6.



A07225

Fig. 5 - Press Tabs to Remove Backplate

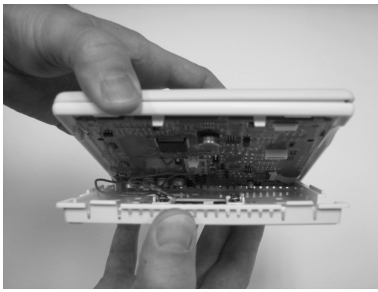

A07226

Fig. 6 - Take Apart

2. Route wires through large hole in mounting base. Level mounting base against wall (for aesthetic value only—Display Module need not be leveled for proper operation) and mark wall through 4 mounting holes. To avoid unintended bending of wall plate plastic, use all 4 screws and anchors. See Fig. 7.

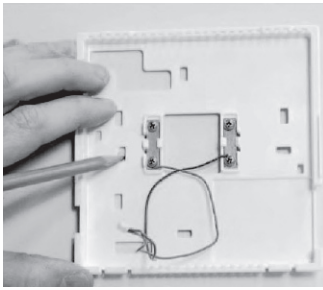

A07165

Fig. 7 - Backplate Mounting

3. Drill two 3/16-in. mounting holes in wall where marked. Thermostat may be mounted to a standard junction box, if desired. Hole pattern on thermostat mounting base matches junction box mounting holes.
4. Secure rear plastic mounting base to wall with 4 screws and anchors provided. To avoid unintended bending of wall plate plastic, use all 4 screws and anchors. Make sure all wires extend through hole in mounting base.
5. Adjust length and routing of each wire to reach proper connector block and terminal on mounting base with 1/4-in. (6 mm) extra wire.
6. Match and connect equipment wires to proper terminals of each connector block being careful not to over tighten the screws. Correct polarity must be observed when connecting the two wires from the Equipment Control Module to the thermostat mounting base. If wires are connected incorrectly, the Display Module will not operate. See Fig. 7, 9 and 10.

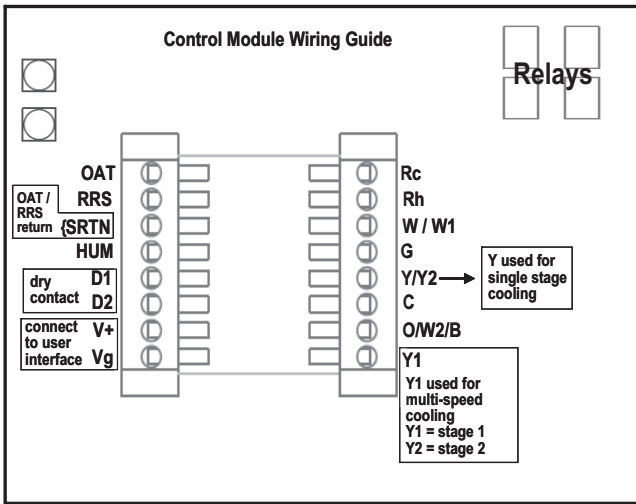

HUM terminal is not used on this model.

A07687

Fig. 8 - Control Module Wiring Guide

- Red is V+
- Black is Vg

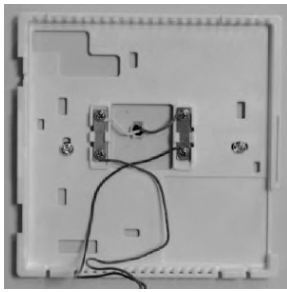

Fig. 9 - Secure Wires to Terminal Strip

A07166

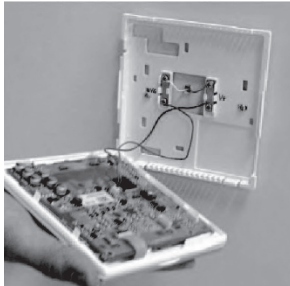
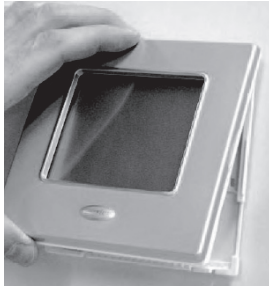

Fig. 10 - Connect Pigtail Wires to Display Module

A07167

NOTE: The 2-wire pigtail is not intended to support the weight of the User Interface. Do not hang the User Interface from the equipment Control Module screw terminals.

- Red is V+
 - Black is Vg
7. Push any excess wire into wall and against mounting base. Seal hole in wall to prevent air leaks. Leaks can affect operation and cause incorrect temperature measurement.
 8. Make sure to attach 2-wire pigtail to Display Module mounting base. It is packed loose in the box from the factory. Then attach 2-wire pigtail to the back of the Display Module via 2 pin, keyed connector.
 9. Reattach Display Module body to mounting base by first setting on at top of mounting base and then push bottom corners of Display Module to snap into place. See Fig. 11.



A07168

Fig. 11 - Attach Display to Backplate

10. Find suitable indoor mounting location for Equipment Control Module, either near or on equipment. See Fig. 12.

IMPORTANT NOTE: Equipment Control Module should not be mounted to duct work or below any other controls or equipment (i.e. humidistat, humidifier, etc.)

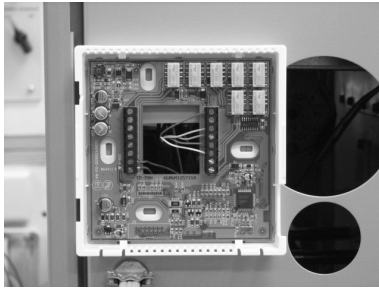

A07217

Fig. 12 - Equipment Control Module on Equipment

11. Route wires through rear of Equipment Control Module using either a clearance hole or supplied standoff. See Fig. 13.

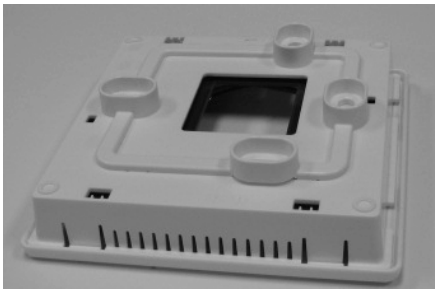

A07227

Fig. 13 - Standoff

NOTE: Standoffs are provided as an aid when installing Equipment Control Module on inside equipment or a solid wall.

12. Match and connect equipment wires to proper terminals of each connector block being careful not to over tighten the screws. Correct polarity must be observed when connecting the two wires from the Equipment Control Module to the thermostat mounting base. If wires are connected incorrectly, the Display Module will not operate. See Fig. 8 and 9.
13. Snap cover over top of Equipment Control Module. See Fig. 14.



A07218

Fig. 14 - Cover on Equipment Control Module

14. Turn on power to equipment. On power up, all display segments will light for 5 sec. For the next 5 sec a 2-digit code appears on large display which identifies AC/HP Control configuration. Refer to Option 33.
 - a. AC — 1-stage air conditioner, AC, with furnace or fan coil
 - b. HP — 1-stage heat pump, HP only with fan coil
 - c. H — heating only system, furnace only or fan coil with electric heat only
 - d. C — cooling only system, AC with fan coil
 - e. H2 — 2-stage heat pump with fan coil
 - f. A2 — 2-stage air conditioner with fan coil or furnace

Single-Piece Installation

The following steps should be followed for the installation of the single-piece configuration.

1. Remove cover from Equipment Control Module by pressing the two tabs on the bottom edge and pulling away. Route wires through large hole in Equipment Control Module. Level Equipment Control Module against wall (for aesthetic value only - Equipment Control Module need not be leveled for proper operation) and mark wall through 4 mounting holes. To avoid unintended bending of wall plate plastic, use all 4 screws and anchors.
2. Drill four 3/16-in. mounting holes in wall where marked. Thermostat may be mounted to a standard junction box if desired. Hole pattern on Equipment Control Module matches junction box mounting holes.
3. Secure rear plastic Equipment Control Module to wall with 4 screws and anchors provided. To avoid unintended bending of wall plate plastic, use all 4 screws and anchors. Make sure all wires extend through hole in Equipment Control Module.
4. Adjust length and routing of each wire to reach proper connector block and terminal on Equipment Control Module with 1/4-in. (6 mm) extra length. See Fig. 15.

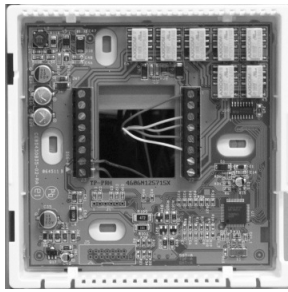

A07219

Fig. 15 - Equipment Control Module

5. Match and connect equipment wires to proper terminals of each connector block.
6. Push any excess wire into wall and against Equipment Control Module. Seal hole in wall to prevent air leaks. Leaks can affect operation and cause incorrect temperature measurement.
7. Remove 2-wire pigtail from thermostat mounting base and attach to Equipment Control Module terminal block (terminals V+ and Vg). Attach 2-wire pigtail to the back of the Display Module via 2 pin, keyed connector.
8. Reattach Display Module body to Equipment Control Module by first setting on at top and then push bottom corners to snap into place. See Fig. 16.



A07220

Fig. 16 - Reattach Display Module

9. Turn on power to equipment. On power up, all display segments will light for 5 sec. For the next 5 sec a 2-digit code appears on large display which identifies AC/HP Control configuration. Refer to Option 33.
 - a. AC — 1-stage air conditioner, AC, with furnace or fan coil
 - b. HP — 1-stage heat pump, HP only with fan coil
 - c. H — heating only system, furnace only or fan coil with electric heat only
 - d. C — cooling only system, AC with fan coil
 - e. H2 — 2-stage heat pump with fan coil
 - f. A2 — 2-stage air conditioner with fan coil or furnace

Set AC/HP Control Configuration

Configuration options enable the installer to configure the thermostat for a particular installation. Most are not presented to the homeowner and therefore must

be properly set by the installer. (Only those marked with an asterisk * below are available to the homeowner.) The homeowner configurations are described in the owner's manual. A special procedure allows entry into the configuration mode. Description of each selection and how to use the configuration mode follows.

CONFIGURATION OPTIONS - SUMMARY

- Option 01 — Equipment Type
- Option 02 — Clean Filter Timer Adjustment
- Option 03* — Fahrenheit/Centigrade Selection
- Option 04 — Fan (G) on with W/W1 Selection
- Option 05 — Room Air Temperature Sensing (programmable models only)
- Option 06 — Cooling Lockout Below 55°F/13°C Selection (only available if outdoor air sensor is present)
- Option 07 — Zoning
- Option 08 — Auxiliary Heat Lockout Temperature Setting (only available when heat pump is used and when outdoor air temperature sensor is present)
- Option 10 — Reversing Valve
- Option 11 — Adjustable Setpoint Deadband
- Option 12 — Smart Recovery (programmable models only)
- Option 13 — Room Temperature Offset Adjustment
- Option 15 — Enable Auto Mode
- Option 16 — Cycles Per Hour
- Option 17 — Time Between Stages
- Option 18* — Backlight Configuration
- Option 19 — Dry Contact (programmable models only)

- Option 20 — Outdoor Air Temperature Offset Adjustment
- Option 21* — Keypad Lockout
- Option 24* — Programmable/Non-Programmable
(programmable models only)
- Option 25* — Number of Programmable Periods per Day
(programmable models only)
- Option 26 — Minimum Cooling Setpoint
- Option 27 — Maximum heating Setpoint
- Option 28 — UV Light Reminder
- Option 30* — Programmable Fan (programmable models only)
- Option 31* — Daylight Savings Time Configuration
(programmable models only)
- Option 32 — Furnace Heat Staging
- Option 33 — Single or Two-Piece Installation
- Option 41 — Variable Speed Blower
- Option 44 — Super Comfort Heat
- Option 99 — Reset to Factory Defaults

TO ENTER CONFIGURATION MODE

Press and hold FAN button for approximately 10 sec. The Display Module is now in configuration mode. It will automatically exit this mode if no button is pressed for 3 minutes. Pressing either FAN or DONE button will exit configuration mode immediately.

WHILE IN CONFIGURATION MODE

The option number is displayed in the heat setpoint location and the configuration setting is displayed in the cool setpoint location. On the TP-PAC/PHP (programmable) models, a box will surround the option number. The mode button is used to move the box between the two displayed values. The soft keys below the listed values may also be used to move the box between selected values. The value inside the box is changed by using the UP/DOWN buttons. On the TP-NAC/NHP (non-programmable) models, one of the values will be flashing. The mode button is used to change which value is flashing or the Home and Sleep buttons may also be used to select which value to flash. The value that is flashing is changed by using the UP/Down buttons. All changes made are saved at the time of selection and will be saved in the event of the 3 minute time-out or when installer exits from configuration menu.

Configuration Options —Selection

Option 01 — Equipment Type

HP model — Range: HP, AC, H, C, H2, A2.

AC model — Range: AC, H, C.

HP — operates a single-speed heat pump with a fan coil.

AC — operates a single-speed AC.

H — operates a heat-only system. Furnace or fan coil only; no outdoor unit.

C — operates a cool only-system. Outdoor AC unit with an indoor fan coil with no strip heaters.

A2 — 2-stage air conditioner with a furnace or fan coil.

H2 — 2-stage heat pump with a fan coil.

Defaults

HP model defaults to HP.

AC model defaults to AC.

Option 02 — Clean Filter Timer

Select hours of blower operation (heating, cooling, or fan) before CHECK FILTER icon is displayed. With OF selected, icon will never come on, disabling this feature. Time selection can range from 800 to 7200 hr by selecting numbers 1 through 9. (Time is 800 X number selected.) Default is 4 (3200 hr).

Recommended selections are disposable filter-800 to 2400 hr, media filter-2400 to 3200 hr, or electronic air cleaner-1600 to 2400 hr of blower operation. For higher efficiency filter, please consult filter's Installation Instruction for details.

Option 03 — Fahrenheit/Centigrade

Select between Fahrenheit (F) and Centigrade (C) operation. Factory default is Fahrenheit (F).

Option 04 — Fan (G) On With W/W1

This selection determines whether fan (G) output is to be On or OFF when any W/W1 (furnace or strip heat) output is On. Most furnaces and fan coils manage their own blowers and do not require separate G signal. For these applications, select OFF. Some auxiliary heaters require separate G signal to turn on blower. In this case, select On.

Default is OF (off).

Option 05 — Room Air Temperature Sensing (programmable models only)

The remote room sensor may be installed as a single sensor or multiple sensors may be installed for further averaging functionality. See Fig. 17

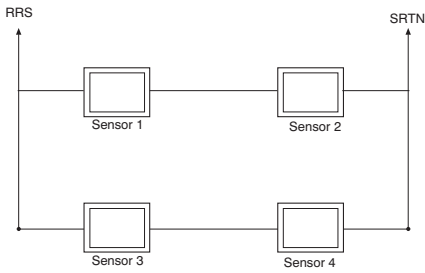

A09130

Fig. 17 - Remote Room Sensor - Parallel Wiring

This selection determines which sensor the control will use for measuring room air temperature. Room air temperature can be sensed in one of three ways; the local sensor (L) located on the Display Module, the remote room air sensor (r), or the average of local and remote sensors (Lr). Settings are L, r, Lr.

Default is L.

Option 06 — Cooling Lockout Below 55°F/13°C

This selection disables cooling when outdoor temperature is below 55°F/13°C. It requires an outdoor temperature sensor. Setting is not available if valid outdoor sensor is not connected. Set to OF (off) to allow cooling below 55°F/13°C. Set to On to prevent cooling below 55°F/13°C.

Factory default is OF (off).

Option 07 — Zoning

This selection should be set to On when the thermostat is to be used as part of a zoning system. It is assumed that the zoning equipment will take care of time guard and cycle timers. The minimum on time is still controlled by the thermostat.

Default is OF (off).

Option 08 — Auxiliary Heat Lockout Temperature

This selection is available on heat pump systems with a valid outdoor temperature sensor connected. Available settings are: Off, 5, 10, 15, 20, 25, 30, 35, 40, 45, 50, 55.

OF (off) - function is disabled. Auxiliary heat is allowed to operate whenever sufficient demand for heat is available.

5 to 55°F (-15 to 13°C) - Outdoor temperature above which the auxiliary heat is not allowed to operate (unless MODE is set to Emergency Heat). If room temperature falls below 45°F (7°C), the auxiliary heat will be allowed to turn on and will continue to run until demand is satisfied.

Default is OF (off).

Option 10 — Reversing Valve

This selection is only available on heat pump systems. “O” terminal can be configured to be energized in either heating mode or in cooling mode, depending on heat pump operation. “O” is used to describe a heat pump system that energizes its reversing valve in cooling. “B” is used to describe a heat pump system that energizes its reversing valve in heating.

H — Reversing valve output (O/W2/B) is energized when HEAT mode is selected.

C — Reversing valve output (O/W2/B) is energized when COOL mode is selected.

Default is C.

Option 11 — Deadband Setting Between Heat & Cool

This option is not available on Heat Only and Cool Only systems. This selection is to allow the installer to choose how much differential exists between the heating and cooling setpoints. Allowable selections are 1-6.

Default is 2.

Option 12 — Smart Recovery

Smart Recovery OF (off) means setpoints change precisely at setback recovery time. Thirty, 60, or 90 selects the number of minutes recovery starts before programmed recovery time. Recovery takes place smoothly during the selected recovery time, ending at the recovery time and temperature which is programmed. Not available with non-programmable thermostats or when thermostat is configured as non-programmable.

Default is 90.

Option 13 — Room Air Temperature Offset Adjust

The number of degrees to be added to the displayed temperature to calibrate or deliberately miscalibrate the measured room temperature (-5 to +5°).

Default is 0.

Option 15 — Enable Auto Mode

This selection is not available if the thermostat is configured as Heat Only or Cool Only in Option 1. This allows the homeowner to select auto changeover mode in addition to heat and cool. This allows the thermostat to automatically change between heating mode and cooling mode when sufficient demand for heating or cooling exists.

On — Auto mode is available.

OF — Auto mode is not available.

Default is On.

Option 16 — Maximum Cycles Per Hour

This selection limits the number of cycles per hour that the thermostat allows the system to operate. Selections are 2, 4, 6.

2 — The heating and cooling outputs will be energized no more than 2 times per hour. When an output is energized, it will not be energized again for 30 minutes.

4 — The heating and cooling outputs will be energized no more than 4 times per hour. When an output is energized, it will not be energized again for 15 minutes.

6 — The heating and cooling outputs will be energized no more than 6 times per hour. When an output is energized, it will not be energized again for 10 minutes.

Default is 4.

Option 17 — Time Between Equipment Stages

This selection is only available for heat pump systems. This determines the minimum number of minutes of equipment operation on the highest compressor stage before allowing the transition to auxiliary heat. Available selections are 10, 15, 20, and 25. The time between stages of any individual piece of equipment, such as low speed and high speed compressor or fan coil stages, will be fixed at 10 minutes.

Default is 15.

Option 18 — Backlight Configuration

When OF (off), the backlight will be lit for 10 seconds after a button is pressed. After 10 seconds of no button presses, the backlight turns off. When On, the backlight will normally be on and dim in appearance. The backlight brightness becomes brighter when a button is pressed. After 10 seconds of no button presses, the backlight will return to the dimmer level until another button press occurs. The range of brightness is 1 through 5 with 5 being full brightness.

Default is 3.

Option 19 — Dry Contact Configuration (programmable models only)

There are 2 available selections, OF and 1.

OF — The dry contact is always de-energized.

1 — The dry contact will be energized for the specified number of minutes per hour. This selection is programmable by period. When this selection is changed from OF to 1, the period icons are shown and the minute segments of the clock display are shown. The triangle icon next to the WAKE period will be on and a value between 0 and 60 will be shown in the minutes display. See Operational Information and Wiring Diagrams for further explanation of dry contact configuration and use. To change the period or minutes, press the soft key below the period or minutes and then use the UP/DOWN buttons to change to the desired value.

Default is OF (off).

Option 20 — Outdoor Air Temperature Offset Adjustment

This selection allows the calibration, or deliberate miscalibration of the outdoor air temperature sensor reading. The selection ranges from -5 to +5°.

Default is 0.

Option 21 — Keypad Lockout (programmable models only)

This selection allows the installer to limit access to the keypad. Selections are OF (off), 1, 2, 3.

OF (off) — The user has full access to the keypad.

1 — The user has access to modify setpoints, time of day.

2 — The user has access to change the setpoints only.

3 — The entire keypad is locked. When a button is pressed, the backlight will turn on but none of the operating parameters will be changed.

When the keypad lock selection is turned on, the padlock icon will be displayed. To unlock the keypad, press and hold the UP/DOWN buttons simultaneously for five seconds. When the keypad is unlocked, the padlock icon will turn off. The keypad will remain unlocked for two minutes after the last button press. After two minutes with no button presses, the keypad will lock again. The keypad will not lock in the software configuration mode or in the installer test mode.

Default is OF (off).

Option 21 — Keypad Lockout (non-programmable models only)

This selection allows the installer to limit access to the keypad. Selections are OF (off), 1, 2.

OF (off) — The user has full access to the keypad.

1 — The user has access to change the setpoints.

2 — The entire keypad is locked. When a button is pressed, the backlight will turn on but none of the operating parameters will be changed.

When the keypad lock selection is turned on, the padlock icon will be displayed. To unlock the keypad, press and hold the UP/DOWN buttons simultaneously for five seconds. When the keypad is unlocked, the padlock icon will turn off. The keypad will remain unlocked for two minutes after the last button press. After two minutes with no button presses, the keypad will lock again. The keypad will not lock in the software configuration mode or in the installer test mode.

Default is OF (off).

Option 22 — High Cool Latch Temperature (only available if outdoor sensor is present)

An outdoor sensor is required for high cool latch feature.

This selection is only available when Option 1 is set to H2, A2, or h2 and when Option 7 (zoning) is set to OF (off). Configuration settings are OF (off), 80, 85, 90, 95, 100, 105, 110, On.

OF (off) — Cooling always starts in low stage (Y1) and stages up to high stage (Y1 and Y/Y2) when demand is sufficient and staging timer constraints have been satisfied.

80 to 110°F (27 to 43°C) — Outdoor temperature above which both first and second stages of the compressor are energized to satisfy all cooling demands. When a cycle starts under a high cool latch, it will finish the cooling cycle on high stage.

On — The Y1 and Y/Y2 outputs are simultaneously energized to satisfy all cooling demands.

Default is OF (off).

Option 23 — High Heat Latch Temperature (only available if outdoor sensor is present)

This selection is only available when Option 1 is set to H2, or h2 and Option 7 (zoning) is set to OF (off). Configuration settings are OF (off), 20, 25, 30, 35, 40, 45, 50, On.

OF (off) — Heating always starts in low stage (Y1) and stages up to high stage (Y1 and Y/Y2) when demand is sufficient and staging timer constraints have been satisfied.

20 to 50°F (-7 to 10°C) — Outdoor temperature below which both first and second stages of the compressor are energized to satisfy all heating demands. When a cycle starts under a high heat latch, it will finish the heating cycle on high stage.

On — The Y1 and Y/Y2 outputs are simultaneously energized to satisfy all heating demands.

Default is OF (off).

Option 24 — Programmable/Non-Programmable

This selection allows the installer to configure the thermostat as either programmable or non-programmable. Selections are P, nP.

Default is P (programmable models only).

Option 25 — Number of Programmable Periods

This selection allows the installer to configure the thermostat for two or four periods per day. Two periods is a common commercial application and four periods is more common for residential. This selection is not available if Option 24 has been set to nP to configure the thermostat for non-programmable operation.

2 — Periods DAY and SLEEP are available

4 — Periods WAKE, DAY, EVE, and SLEEP are available.

Default is 4.

Option 26 — Minimum Cooling Setpoint

This selection allows the installer to configure the minimum cooling setpoint that the user is allowed to set. The range is based on the value of the adjustable deadband Option 11, such that the minimum of the range is 50°F/10°C plus the adjustable deadband and the maximum is 90°F/32°C.

Default is 52°F/11°C (based on the adjustable deadband default = 2).

Option 27 — Maximum Heating Setpoint

This selection allows the installer to configure the maximum heating setpoint. The range is based on the adjustable deadband value Option 11, such that the minimum of the range is 50°F/10°C and the maximum is 90°F/32°C minus the deadband.

Default is 88°F/31°C (based on the adjustable deadband default = 2).

Option 28 — UV Light Reminder

This selection allows the installer to select the number of months after which the UV Light icon will be displayed to indicate to the homeowner that it is time to call the dealer to have the UV Lights replaced. Selections available are OF (off), 6, 12, 18, 24, 30, 36, 42, 48.

OF (off) — The UV Light reminder is turned off and will never be displayed.

6-48 — The number of months after which the UV Light reminder will be displayed, “CHECK UV LIGHT”.

Default is OF (off).

Option 30 — Programmable Fan (programmable models only)

This selection allows the homeowner to program the fan selection to “Auto” or “On” fan operation for each of the program schedule periods. This selection is only available on programmable models.

OF (off) — Programmable fan is disabled and the homeowner must manually select “Auto” or “On” for fan operation.

On — Programmable fan is enabled. The homeowner can program “Auto” or “On” fan operation along with the heat and cool setpoints for each programmed period. When the program schedule is running, the programmed heat setpoint, cool setpoint, and fan selection for that period will be used. If the homeowner “overrides” the programmed fan setting by pressing the fan button, the override selection will remain in effect until the next programmed period time.

Default is OF (off).

Option 31 — Daylight Savings Time Configuration (programmable models only)

This selection allows the installer to set the thermostat to automatically change by one hour on the specified day, month, and week specified.

OF (off) — Daylight Savings Time Function disabled.

1,2 On — The first time the UP/DOWN button is pressed, the value of this selection changes from OF (off) to 1. When 1 is displayed, the days of the week and clock digits will be turned on. The installer will set the start date (Spring) for Daylight Savings Time by setting the day of the week by selecting the appropriate triangle icon next to the days of the week, the month of the year will be set in the clock hours location (range 1-12) and the week of the month will be set in the clock minutes location. The week of the month selections will be F, 2, 3, 4, and L for First, 2nd, 3rd, 4th, and Last. So for the first Sunday in April, the display would show SUN, 4, F. When 2 is displayed, the installer will then choose the end date for daylight savings time (Fall). To activate the function, the installer changes the “2” by pressing the up button and “On” is displayed. The setting shall be left “On” to enable the Daylight Savings Time function.

Default is OF (off).

Option 32 — Furnace Heat Staging Control (available only when the HP thermostat is configured to operate AC equipment or Heat Only).

1 — Thermostat controls W1 output only and furnace controls the turn on and turn off of higher stages of heat.

2 — Thermostat will control the W1 and O/W2/B outputs.

Default is 1.

Option 33 — Single or Two-Piece Installation

This configuration allows the thermostat to compensate for the amount of heat generated by the thermostat electronics to allow more accurate sensing of the temperature sensor. The amount of heat compensation will be different between single installation and two-piece installation.

Range: 1P or 2P

1P — The installation is single piece.

2P — The installation is two separate pieces.

Default is 2P.

Option 41 — Variable Speed Blower

This selection allows the installer to select between a single speed or variable motor.

Off - The system has a single speed (PSC) blower.

On - The system has a variable speed blower.

Factory default is OF (Off)

Option 44 — Super Comfort Heat

This option is only available on heat pump units HP (HP, H2) when Option 41 (Variable Speed Blower) is set to On and the system has a valid OAT sensor.

OF (Off) - Comfort Heat is off

On - Comfort Heat feature is on.

If the outdoor air temperature is between 12 to 40°F (-11 to 4°C) and the compressor is running in heating, then the fan output is turned off. This will signal the variable speed blower to reduce the air speed. The fan output is turned off even if the user has the fan selection set to continuous fan. The fan output will be turned back on in this temperature range if the maximum capacity of auxiliary heat is on due to system demand (auxiliary heat on in response to a defrost signal shouldn't cause the fan to turn back on).

If the outdoor air temperature is below 12°F/-11°C and there is sufficient demand for the equipment to be on, then the fan output is turned back on and the W/W1 output is energized. In a two speed unit the Y/Y2 output should be energized in addition to the W/W1 output.

NOTE: All temperature boundaries have a +/- 2° hysteresis.

Factory default is OF (Off).

Option 99 — Reset to Factory Defaults

Use this capability to reset the stat to “out of the box” conditions. BEWARE! All configuration settings, program settings, clock, and calendar which have been manually entered will be lost!

When this option is selected, the configuration number (99), will appear on the left and 10 will appear on the right. To perform the reset, first use the MODE key to move the box from the 99 to the 10 (programmable model) or to flash the 10 (non-programmable model). Then press and hold the DOWN key. The 10 will start counting down toward zero. If the DOWN key is kept pressed until the count reaches zero, the reset will be performed. When the value reaches zero, the heat setpoint shall display --. The cool setpoint shall display - and the room air temperature shall display Fd. When the factory defaults have been restored, the thermostat will act as if power was cycled and return to normal operation. If the DOWN key is released early, the number will return to 10 and the reset will not occur.

SYSTEM START-UP AND CHECKOUT

The AC/HP Control is designed with a built-in installer test capability. It allows easy operation of equipment without delays or setpoint adjustments to force heating or cooling. To enable installer test mode, press and hold the fan button for 15 seconds. After 10 seconds, the thermostat will enter Configuration Mode. Continuing to hold the Fan button through 15 seconds will cause the thermostat to enter Installer Test Mode. Pressing the Mode button will change the system operating mode to test the heating and cooling equipment. Auto Mode is not available during Installer Test Mode. If no buttons are pressed for 15 minutes, the installer test mode will be terminated. Pressing DONE at any time will exit installer test mode.

Heat - The first stage of heating will be energized for three minutes, then the first and second stages (if a second stage exists) will turn on for an additional three minutes. During the first stage of heating, the HEAT ON icon will be displayed. The “auxiliary heat on” icon will be displayed if the second stage is electric heat (HP unit type). For heat pump installation, only 1 stage of auxiliary heat is available. Any staging of auxiliary heat must be managed by the furnace or fan coil. At the end of the equipment cycle the MODE will return to OFF. The display will count down from 180 seconds to 0 for each stage when the equipment is energized. The test of a heating or cooling cycle can be terminated before the timer expires by pressing the MODE button and changing the system mode to OFF.

Installer test for cooling is the same as described for heating above. COOL ON will be displayed during cooling in Installer Test Mode. In a heat pump application, when the mode is set to “em heat” the auxiliary heat will turn on for 3 minutes. The clock display will count down from 180 to 0 during this test.

TO TEST FAN

Fan button switches FAN icon between AUTO and On. While On is displayed, G output will be energized, turning fan on. On some fan coils, fan continues to operate for 90 sec after G signal is removed.

Final Settings

Be sure to press DONE to exit installer setup mode. If the system is to be left in operation after installation is complete, use MODE button to select between HEAT, COOL, or AUTO to provide desired operation of heating, cooling, or auto.

On the programmable models, the default setpoints and programmed schedule conform to the Energy Star® requirements of the U.S. Department of Energy for both heating and cooling. These provide energy saving temperature settings. Refer to Table 1.

Table 1 – Energy Star Default Schedule

SCHEDULE	HEAT	COOL
Wake 6:00 AM	68°F/20°C	78°F/26°C
Day 8:00 AM	60°F/16°C	85°F/29°C
Evening 5:00 PM	68°F/20°C	78°F/26°C
Sleep 10:00 PM	60°F/16°C	82°F/28°C

If the programmed schedule is to be used, make sure the triangle icon next to the FOLLOW SCHEDULE icon is turned on. Pressing the Schedule button will cycle the triangle icon through the FOLLOW SCHEDULE, HOLD and VACATION selections.

If fixed temperatures are desired, use SCHEDULE button to turn on arrow icon next to HOLD. This will maintain setpoints, not allowing them to change with programmed schedule.

The FAN button may be used to select between AUTO (fan on only with equipment) and On (fan on continuously) fan modes. For further information on temperature selection and programming, refer to Homeowner's Guide.

Setting The Clock, Calendar, Daily Schedule, and Vacation Settings (programmable models only)

To set the clock, press the SET button once. The Clock will be displayed at the bottom center of the screen. Use the soft keys to move the box around the digits to be set and the UP/DOWN buttons to change the setting. Concurrent presses of the set button will cycle through the calendar, daily schedule, and vacation settings.

Calendar may be changed by using the soft keys to select the Month, Day, or Year. The UP/DOWN buttons are used to change the Month, Day, or Year setting when the box surrounds it. Day of the week (Mon-Sun) is determined by calendar settings and is not directly adjustable.

When changing daily schedule settings, the soft keys are used to set the days, period times, heating setpoints, and cooling setpoints. The UP/DOWN buttons are used to change the setting with the box around it. ALL PROGRAM PERIODS (WAKE, DAY, EVE, SLEEP) MUST OCCUR WITHIN THE SAME 24 HOUR PERIOD.

When changing Vacation settings, the soft keys are used to choose the selection to be adjusted and the UP/DOWN buttons are used to change the setting.

Vacation (programmable models only)

A vacation selection is available specifically for times where the home will not be occupied for an extended period. Vacation mode has an automatic hold, meaning that setpoints are not affected by the programmed schedule. Vacation mode is active for a specified period of time. While in vacation mode, the system provides temperature protection for the home in the selected mode, but not comfort. When vacation mode is active, an arrow will be displayed beside "VACATION" in the upper left corner of the display.

Vacation Setpoints

A special set of temperature setpoints exist which are active in vacation mode. They are adjustable by the homeowner, are exclusively for vacation mode, and are remembered from one vacation selection to the next. See Table 2 for default values.

Table 2 – Vacation Setpoints Default Values

MODE	AUTO
Fan	Auto
Heat Setpoint	55°F/13°C
Cool Setpoint	85°F/29°C

OPERATIONAL INFORMATION

Timers

Five-Minute Compressor Timeguard

This timer prevents compressor from starting unless it has been off for at least 5 minutes. It can be overridden for 1 cycle by simultaneously pressing FAN and UP buttons.

Cycle Timer

Based on the selection of 2, 4, or 6 cycles per hour, this timer is set to 30, 15, or 10 minutes. This much time must elapse from the start of one cycle before another cycle can start. It serves to impose the cycles per hour limits. It can be defeated for one cycle by simultaneously pressing the FAN and UP buttons.

Ten-Minute Staging Timer

In multistage heating or cooling, this timer prevents any higher stage from turning on until preceding stage has been on for 10 minutes. When staging between compressor and electric heat or between compressor and furnace heat, the time is configurable. The timer is configurable via Option 17. This timer is overridden if temperature error is greater than 5° (usually due to a large change in desired temperature) and equipment stages up in 60 second intervals.

The ten-minute staging timer does not require the thermostat to change to a higher stage after 10 minutes. If the system is able to meet the demand (maintain setpoint) it may not change stages after the 10 minute timer has expired. If there is sufficient demand for a higher stage at the end of 10 minutes or at any time after the 10 minute timer has expired, the thermostat will energize the next higher stage.

Defrost

Detection of defrost will not work properly if the installer has configured the O/W2/B output to function as a B output. During heat pump heating, a defrost signal shall be considered valid if the compressor output is energized and the defrost signal has been active for less than 15 consecutive minutes. Any defrost signal present for longer than 15 minutes shall be considered invalid.

Heat pump/fan coil systems shall use this input to:

- Detect that defrost is in progress and energize the auxiliary heat to provide homeowner comfort during the defrost cycle
- Allow a defrost cycle to run to completion regardless of the system demand

Three-Minute Minimum on Time

In normal operation, when a stage turns on, it will not turn off for a minimum of 3 minutes. If the setpoint is changed, this timer is canceled, allowing the equipment to turn off immediately when the demand is removed.

Heat/Cool Setpoints (Desired Temperature)

A minimum difference of 1° and maximum of 6° is enforced between heating and cooling desired temperatures. This is done by allowing 1 setting to “push” the other, to maintain this difference. This difference is adjustable via Configuration Option 11.

Equipment On Indicators

When cooling equipment is on, a COOL ON icon is displayed. While cooling equipment operation is delayed by the timeguard or cycle timer, COOL ON will flash. The same is true for HEAT ON.

When the W is energized in a heat pump, the **auxiliary heat on** icon will be displayed.

Auto Changeover

When auto changeover mode is selected, a change from heat to cool (or vice versa) will not occur until an opposite mode demand has existed for 20 minutes. If setpoint is changed, 20-minute requirement is deleted.

Emergency Heat Mode

When AC/HP Control is configured as a heat pump and emergency heat is selected, all Y signals are locked out, and W becomes energized upon a call for heat.

Programmable Fan (programmable models only)

The fan output can be programmed based on period of the day. When programming for each day and period the fan can be set to On or AUTO. If the fan button is pressed to change from On to Auto or vice versa when programmable fan has been enabled, the manual change will only remain in effect until the next program period, when the programmable fan setting will be changed per the scheduled setting.

Dry Contact

On the programmable models, the dry contact that can be used for control of an auxiliary device. The dry contact may be configured to be closed for a specific number of minutes per hour for each period of the program schedule. This can be used to operate a ventilator, damper, system blower, or other auxiliary device. There are two terminals, D1 and D2.

If it is desired to operate a ventilator or other device, the D1 and D2 terminals can be connected directly to the equipment. This will provide a closed contact for the specified number of minutes per hour. See Option 19.

If timed control of the system blower is required, the dry contact can be used for this function. The G terminal can be connected to one of the dry contact terminals with the other terminal being connected to Rc and/or Rh for timed control of the fan. Note that this is not the same as programmable fan Option 30.

See Wiring Diagrams for more information.

Relays

This thermostat uses latching relays. When the thermostat loses power, the relays will remain in their last position until power is restored and all relays are reset to their correct position. Out of the box, the outputs may appear to be On when the thermostat is not powered. This is normal. Output states should only be checked when the thermostat is powered.

Temperature Offset After Power Cycle

To compensate for internal heat build-up from the electronics in the thermostat, the thermostat will add an offset to the actual temperature that it measures. If the thermostat power is cycled quickly, one can witness an immediate increase in the actual temperature displayed due to this added offset. The thermostat display will return to the actual room temperature after several minutes of operation.

TROUBLESHOOTING

If the display module doesn't power up after power is applied, check the Rc/Rh and C terminals for 24VAC. If 24VAC is present, check the voltage between Vg and V+. This voltage will be approximately 12-20VDC. If voltage is present, check the polarity to make sure it is wired correctly. The display will not power up if polarity is reversed.

If dashes appear for Option 01 in config and during reboot, the problem could be the red pigtail being wired to Rc or Rh and the black pigtail being wired to C. If so, remove the two-wire pigtail and connect to the V+ and Vg terminals.

Error Codes

-- - If AC/HP Control cannot properly read room temperature, display will indicate "--" and all outputs (except fan, if on) will turn off. In the case where the installer has selected to average the local sensor and the remote room sensor, the AC/HP display will alternate between "--" for the failed sensor and the temperature sensed by the working sensor every 10 seconds. The control will operate from the temperature sensed by the working sensor.

E1 - If the Display Module and the Equipment Control Module cannot communicate via two-wire connection, an E1 will be displayed.

E2 - There is no E2 error message.

E3 - If AC/HP Control cannot properly read outdoor temperature, and it is needed for proper operation, display will indicate "--" in the outdoor temperature location.

E4 - If AC/HP Control's internal memory fails, E4 will be displayed. Replace AC/HP Control.

Table 3 can be used as a troubleshooting tool for determining which outputs will be active for a particular configuration and each operating mode.

When replacing a failed component such as an equipment control module or a display module, the installer should replace both parts as a matched set. It is very easy to accidentally mix an A/C or HP display with a PAC equipment control module. When this happens, some functions appear in the setup while others do not. This can be very confusing to troubleshoot. Verify that both parts have the same model and serial number when troubleshooting the thermostat.

Table 3 – Equipment Configuration Outputs

For COOL, HEAT and Emergency Heat modes, the following chart shows the state for each output in each stage of operation

Equip Config	Tstat Model	COOL STG 1	COOL STG 2	HEAT STG 1	HEAT STG 2	HEAT STG 3	HEAT STG 4	EM HEAT STG 1	EM HEAT STG 2
SS AC Opt 1 = AC	TP-PAC TP-NAC	Y/Y2	--	W/W1	--	--	--	--	--
SS AC Opt 1 = AC	TP-PHP TP-NHP	Y/Y2	--	W/W1	W/W1 O/W2/B (if Opt. 32 = 2)	--	--	--	--
SS HP Opt 1 = HP RVS = O Opt 10 = C	TP-PHP TP-NHP	Y/Y2, O/W2/B	--	Y/Y2	Y/Y2, W/W1	Y/Y2 W/W1	--	W/W1	W/W1 Y1/W2
SS HP Opt 1 = HP RVS = B Opt 10 = H	TP-PHP TP-NHP	Y/Y2	--	Y/Y2, O/W2/B	Y/Y2, W/W1, O/W2/B	Y/Y2, W/W1, Y1/W2, O/W2/B	--	W/W1	W/W1 Y1/W2
2SPD AC Opt 1 = A2	TP-PHP TP-NHP	Y1/W2	Y/Y2, Y1/W2	W/W1	W/W1 O/W2/B	--	--	--	--
2SPD HP Opt 1 = H2 RVS = O Opt 10 = C	TP-PHP TP-NHP	Y1/W2, O/W2/B	Y1/W2 Y/Y2 O/W2/B	Y1/W2	Y1/W2 Y/Y2	Y1/W2, Y/Y2, W/W1	--	W/W1	--

Table 3 - Equipment Configuration Outputs (cont.)

Equip Config	Tstat Model	COOL STG 1	COOL STG 2	HEAT STG 1	HEAT STG 2	HEAT STG 3	HEAT STG 4	EM HEAT STG 1	EM HEAT STG 2
2SPD HP Opt 1 = H2 VS = B Opt 10 = H	TP-PHP TP-NHP	Y1/W2	Y1/W2 Y/Y2	Y1/W2 O/W2/B	Y1/W2 Y/Y2 O/W2/B	Y1/W2 Y/Y2 O/W2/B W/W1	--	W/W1	--
Heat Only Unit Opt 1 = H	TP-PHP TP-NHP TP-PAC TP-NAC	--	--	W/W1	If HP or RH board & Opt. 32 = 2 W/W1 O/W2/B	--	--	--	--
Cool Only Unit Opt 1 = C	TP-PHP TP-NHP TP-PAC TP-NAC	Y1/W2	Y1/W2 Y/Y2 ignore for SS	--	--	--	--	--	--

WIRING DIAGRAMS

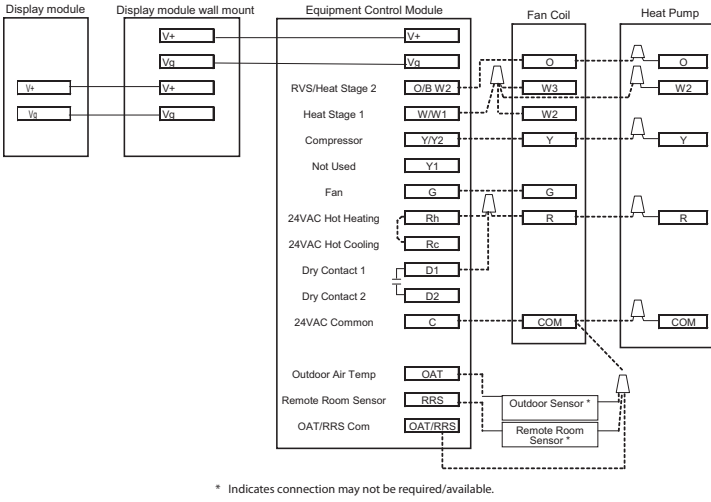

A09174

Fig. 18 - Display to Equipment Control Module Connection

WIRING DIAGRAMS(cont.)

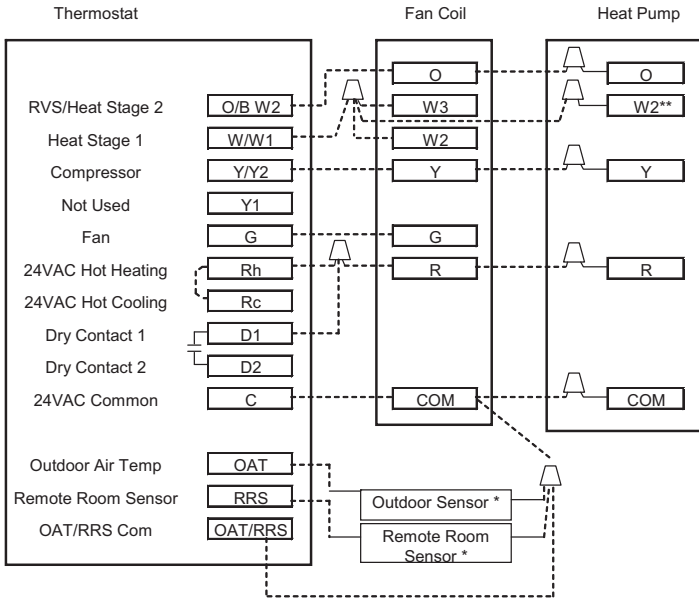

* Indicates connection may not be required/available.

** Some heat pumps may designate W1.

A09154

Fig. 19 - Fan Coil with Heat Pump (HP Thermostat)

WIRING DIAGRAMS(cont.)

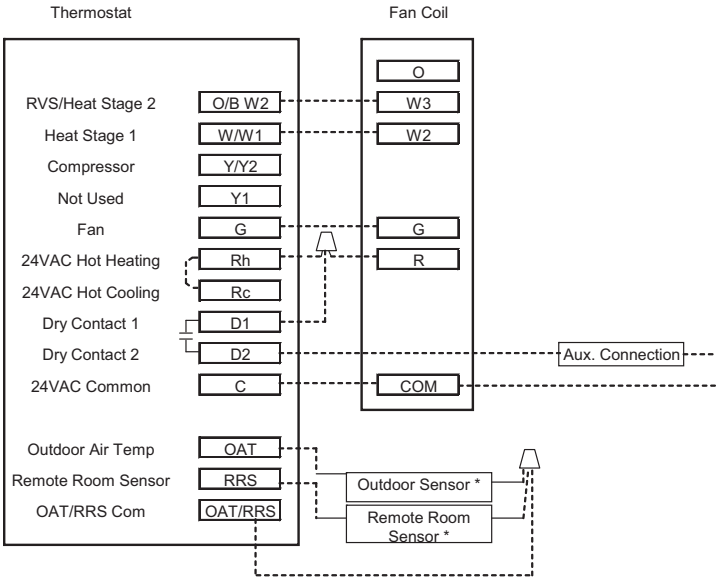

* Indicates connection may not be required/available.

A09155

Fig. 20 - Fan Coil shown with Auxiliary Connection #1

WIRING DIAGRAMS(cont.)

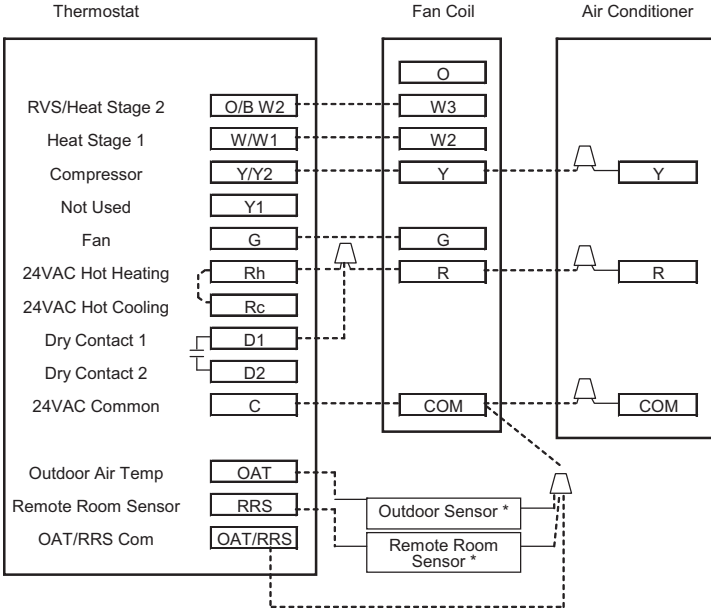

A09175

Fig. 21 - Fan Coil with Air Conditioner

WIRING DIAGRAMS(cont.)

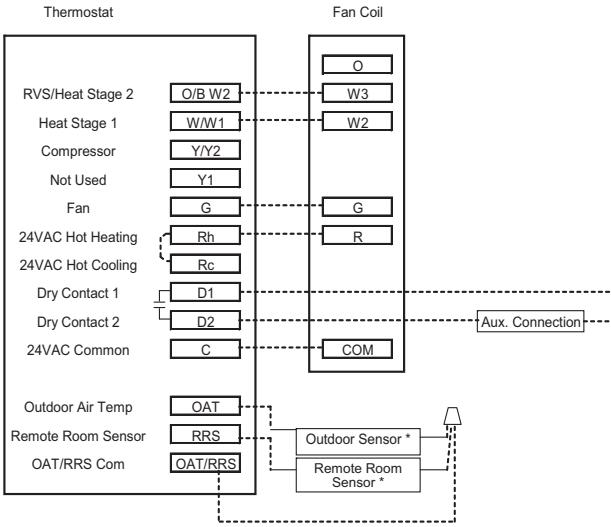

* Indicates connection may not be required/available.

A09156

**Fig. 22 - Fan Coil shown with Auxiliary Connection #2
(Heat pump/air conditioner removed for clarity)**

WIRING DIAGRAMS(cont.)

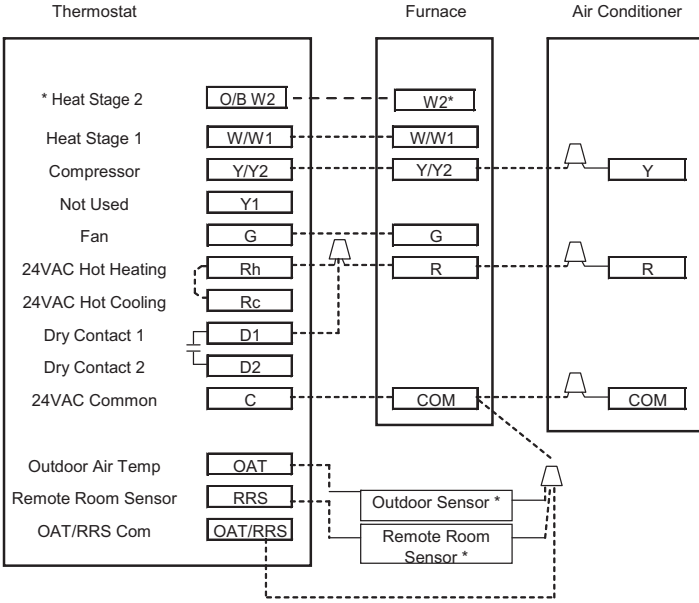

* Indicates connection may not be required/available.

A09157

Fig. 23 - Furnace with Air Conditioner

WIRING DIAGRAMS(cont.)

Thermostat

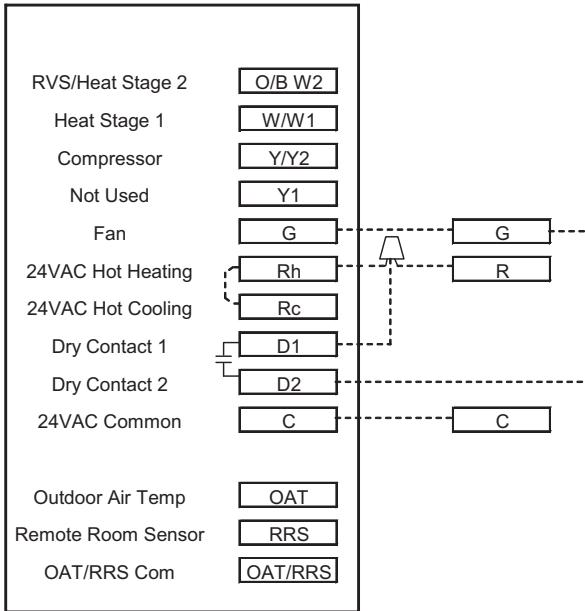

A09158

Fig. 24 - Thermostat with Dry Contact Control for Run Time

WIRING DIAGRAMS(cont.)

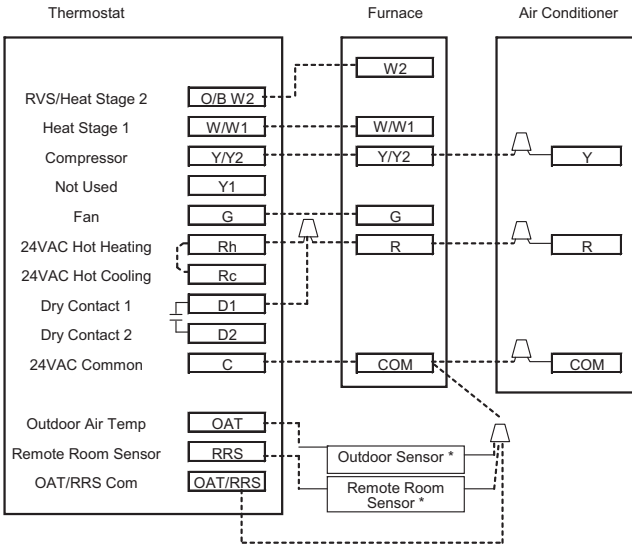

* Indicates connection may not be required/available.

A09159

**Fig. 25 - 2-Stage Furnace with Air Conditioner
(HP Thermostat Configured as AC)**

WIRING DIAGRAMS(cont.)

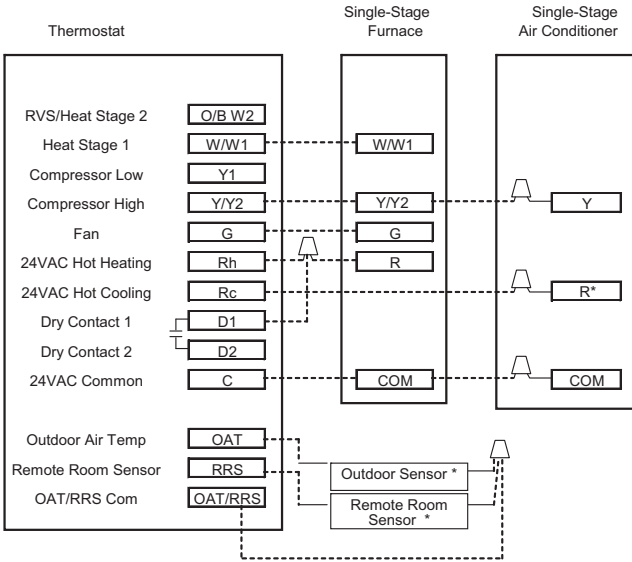

* Indicates connection may not be required/available.
 NOTE: Rc/Rh jumper is cut on the Equipment Control Module.

A09160

Fig. 26 - Single-stage Furnace with Air Conditioner and Split Power

THERMOSTAT CONFIGURATION RECORD

Installer _____ Model Number _____ Date _____

A. Hardware Configuration

_____ Seal Hole In Wall

B. Mode Settings

_____ Mode (Off, Heat, Cool, Auto, Em Heat)

_____ Heating Setpoint Value

_____ Cooling Setpoint Value

_____ Fan (Auto or On)

C. Home, Away, Sleep Settings

Heat Cool

Home _____

Away _____

Sleep _____

D. Schedule (For Programmable Thermostats)

	Period 1			Period 2			Period 3			Period 4		
	Time	Heat	Cool	Time	Heat	Cool	Time	Heat	Cool	Time	Heat	Cool
All Days	_____	_____	_____	_____	_____	_____	_____	_____	_____	_____	_____	_____
Week-days	_____	_____	_____	_____	_____	_____	_____	_____	_____	_____	_____	_____
Week-end	_____	_____	_____	_____	_____	_____	_____	_____	_____	_____	_____	_____

E Configuration Options

Option 01	_____	Equipment Type
Option 02	_____	Clean Filter Timer Adjustment
Option 03*	_____	Fahrenheit/Centigrade Selection
Option 04	_____	Fan (G) on with W/W1 Selection
Option 05	_____	Room Air Temperature Sensing
Option 06	_____	Cooling Lockout Below 55° F/13° C Selection (only available if outdoor air sensor is present)
Option 07	_____	Zoning
Option 08	_____	Auxiliary Heat Lockout Temperature Setting (only available when heat pump is used and when outdoor air temperature sensor is present)
Option 10	_____	Reversing Valve
Option 11	_____	Adjustable Setpoint Deadband
Option 12	_____	Smart Recovery (programmable models only)
Option 13	_____	Room Air Temperature Offset Adjustment
Option 15	_____	Enable Auto Mode
Option 16	_____	Cycles Per Hour
Option 17	_____	Time Between Stages
Option 18*	_____	Backlight Configuration
Option 19	_____	Dry Contact (programmable models only)
Option 20	_____	Outdoor Air Temperature Offset Adjustment

E Configuration Options (cont)

Option 21*	_____	Keypad Lockout
Option 22	_____	High Cool Latch Temperature
Option 23	_____	High Heat Latch Temperature
Option 24*	_____	Programmable/Non-Programmable (programmable models only)
Option 25*	_____	Number of Programmable Periods Per Day (programmable models only)
Option 26	_____	Minimum Cooling Setpoint
Option 27	_____	Maximum Heating Setpoint
Option 28	_____	UV Light Reminder
Option 30*	_____	Programmable Fan (programmable models only)
Option 31*	_____	Daylight Savings Time Configuration (programmable models only)
Option 32	_____	Furnace Heat Staging
Option 33	_____	Single or Two-Piece Installation
Option 41	_____	Variable Speed Blower
Option 44	_____	Super Comfort Heat
Option 99	_____	Reset to Factory Defaults

* Options with an asterisk can also be set/changed by the homeowner.

NOTES

NOTES

NOTES



997-060370-8-R

Copyright 2013 Carrier Corporation 7310 W Morris St. Indianapolis, IN 46231

TP-PACA-01SI

Replaces: NEW

Edition Date: 08/14

Manufacturer reserves the right to change, at any time, specifications and designs without notice and without obligations.