

**GP Performance Series
Geothermal Heat Pump
Sizes 024, 036, 048, 060, 072**



Product Data

FEATURES & BENEFITS



Energy Efficiency

- 3.5 - 4.0 COP, 15.5 - 24.5 EER (Closed Loop)
- 4.0 - 4.6 COP, 19.6 - 30.0 EER (Open Loop)
- Optional supplemental domestic water heating

Comfort

- Two-stage scroll compressor
- Variable speed blower motor

Control

- Microprocessor control
- Smart Start Assist (optional field installed)

Sound

- Fully insulated cabinet with closed cell foam
- Compressor blanket

Reliability, Quality and Durability

- Puron® refrigerant
- Tin plated copper tubing in air coil

Flexibility and Installation

- Unit available in vertical up-flow, down-flow and horizontal
- Compatible with many 3 stage heat, 2 stage cooling programmable thermostats

Indoor Air Quality

- MERV 8, 2" filter

MODEL NUMBER NOMENCLATURE

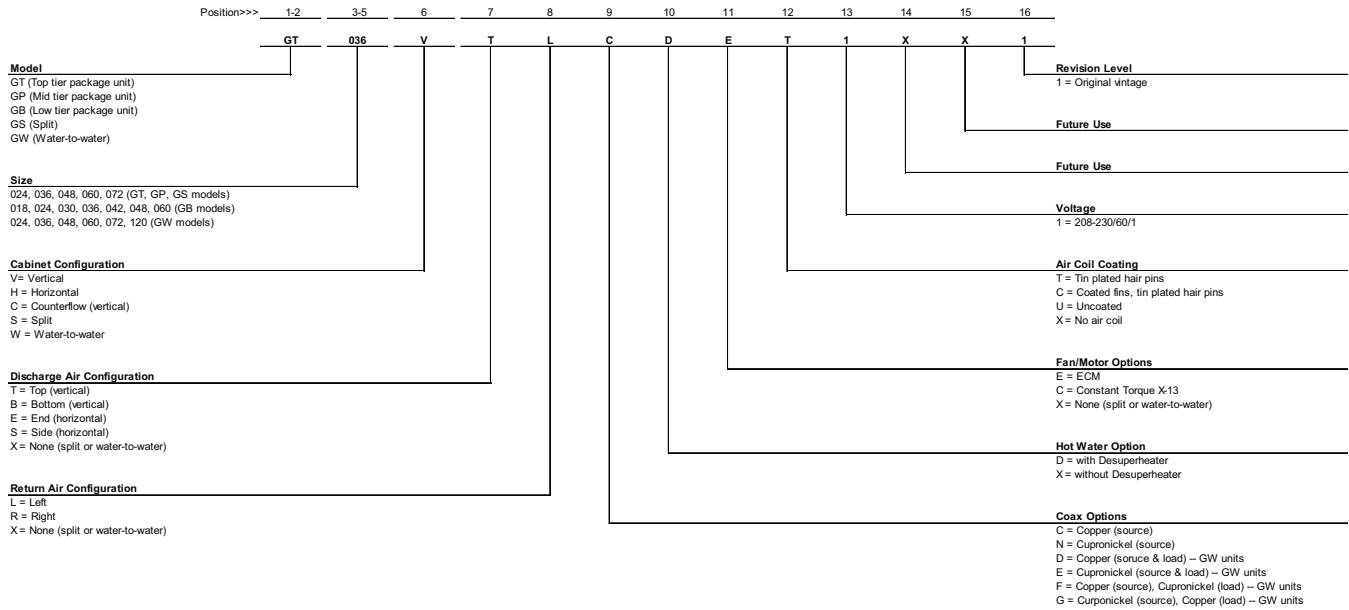

Use of the AHRI Certified TM Mark indicates a manufacturer's participation in the program. For verification of certification for individual products, go to www.ahridirectory.org.



ISO 9001
QMI-SAI Global



This product has been designed and manufactured to meet Energy Star® criteria for energy efficiency when matched with appropriate coil components. However, proper refrigerant charge and proper air flow are critical to achieve rated capacity and efficiency. Installation of this product should follow all manufacturing refrigerant charging and air flow instructions. **Failure to confirm proper charge and air flow may reduce energy efficiency and shorten equipment life.**

AHRI RATINGS

Models	Load	Water Loop				Ground Water				Ground Loop			
		Cooling 86° F		Heating 68° F		Cooling 59° F		Heating 50° F		Cooling 77° F		Heating 32° F	
		Capacity Btuh	EER	Capacity Btuh	COP	Capacity Btuh	EER	Capacity Btuh	COP	Capacity Btuh	EER	Capacity Btuh	COP
GP024	Part	18800	17.5	20500	5.1	21000	30.0	18000	4.6	20000	24.5	15500	4.0
	Full	26000	16.0	30000	5.0	29000	24.0	25000	4.6	27500	18.7	19000	3.8
GP036	Part	24000	17.0	27000	5.3	27000	28.0	22500	4.5	27000	24.5	20500	4.0
	Full	36000	14.6	43000	4.8	42000	21.6	36000	4.2	38000	17.2	28000	3.8
GP048	Part	34000	16.0	39000	5.4	38000	24.0	32000	4.6	36000	21.8	28500	4.0
	Full	48000	12.6	58000	4.8	54000	19.0	48000	4.2	49000	15.5	38000	3.6
GP060	Part	42000	17.0	48000	5.4	48000	26.0	40000	4.6	45000	23.5	36500	4.0
	Full	60000	14.0	72000	4.7	68000	19.7	61000	4.3	62000	15.7	49000	3.6
GP072	Part	51000	15.8	55000	4.4	57000	25.2	47000	4.0	56000	21.8	42000	3.7
	Full	72000	14.5	80000	4.5	77000	19.6	68000	4.2	74000	16.3	53000	3.5

NOTE: Ratings contained in this document are subject to change at any time. Always refer to the AHRI directory (www.ahridirectory.org) for the most up-to-date ratings information.

PHYSICAL DATA

Description	024	036	048	060	072
Compressor Type (Qty 1)	Scroll	Scroll	Scroll	Scroll	Scroll
Max Water Working Pressure (PSIG/kPa)	450/3100	450/3100	450/3100	450/3100	450/3100
ECM Const AirFlow – Eon Fan Motor & Blower					
Fan Motor Type/Speeds	ECM Const Air Flow	ECM Const Air Flow	ECM Const Air Flow	ECM Const Air Flow	ECM Const Air Flow
Fan Motor (HP)	0.33	0.50	0.75	1.00	1.00
Blower Wheel Size (Dia. x W)	9x7	9x7	10x8	11x9	11x9
Water Connection Size					
FPT	3/4"	3/4"	1"	1"	1"
Coaxial Coil Volume (gal)	0.46	0.46	0.62	0.47	0.80
Vertical Cabinet					
Refrigeration Charge (oz)	68	68	78	90	111
Air Coil Dimensions (H x W)	24 X 21	24 X 21	24 X 27	24 X 27	32 X 27
Nominal size of Standard Filter – 1" (L x H)	24 X 24	24 X 24	24 X 30	24 X 30	16 X 30 (2)
Weight – Operating (lbs)	290	290	318	390	450
Weight – Shipping (lbs)	315	315	348	415	495
Horizontal Cabinet					
Refrigeration Charge (oz)	68	68	78	90	111
Air Coil Dimensions (H x W)	18 X 28	18 X 28	20 X 32.5	20 X 32.5	20 X 43
Nominal size of Standard Filter – 1" (L x H)	20 X 30	20 X 30	20 X 34.5	20 X 34.5	20 X 24 (2)
Weight – Operating (lbs)	290	290	318	390	450
Weight – Shipping (lbs)	315	315	348	415	495

BLOWER PERFORMANCE DATA - VARIABLE SPEED CONSTANT CFM

Models	Fan Speed	Rated Airflow	Adjust	Tap	External Static Pressure (in of Water)										
					0.10	0.20	0.30	0.40	0.50	0.60	0.70	0.80	0.90	1.00	
024 – Part Load	Hi	600	+	A	600	600	600	600	600	600	600	600	600	–	–
	Med	500	Normal	A	500	500	500	500	500	500	500	500	500	–	–
	Low	425	–	A	425	425	425	425	425	425	425	425	425	–	–
024 – Full Load	Hi	900	+	A	900	900	900	900	900	900	900	900	900	–	–
	Med	750	Normal	A	750	750	750	750	750	750	750	750	750	–	–
	Low	650	–	A	650	650	650	650	650	650	650	650	650	–	–
036 – Part Load	Hi	1200	+	A	1200	1200	1200	1200	1200	1200	1200	1200	1200	1200	1200
	Med	1050	Normal	A	1050	1050	1050	1050	1050	1050	1050	1050	1050	1050	1050
	Low	900	–	A	900	900	900	900	900	900	900	900	900	900	900
036 – Full Load	Hi	1400	+	A	1400	1400	1400	1400	1400	1400	1400	1400	1400	1400	1400
	Med	1225	Normal	A	1225	1225	1225	1225	1225	1225	1225	1225	1225	1225	1225
	Low	1050	–	A	1050	1050	1050	1050	1050	1050	1050	1050	1050	1050	1050
048 – Part Load	Hi	1100	+	B	1100	1100	1100	1100	1100	1100	1100	1100	1100	1100	1100
	Med	925	Normal	B	925	925	925	925	925	925	925	925	925	925	925
	Low	800	–	B	800	800	800	800	800	800	800	800	800	800	800
048 – Full Load	Hi	1700	+	B	1700	1700	1700	1700	1700	1700	1700	1700	1700	1700	1700
	Med	1500	Normal	B	1500	1500	1500	1500	1500	1500	1500	1500	1500	1500	1500
	Low	1275	–	B	1275	1275	1275	1275	1275	1275	1275	1275	1275	1275	1275
060 – Part Load	Hi	1725	+	A	1725	1725	1725	1725	1725	1725	1725	1725	1725	1725	1725
	Med	1500	Normal	A	1500	1500	1500	1500	1500	1500	1500	1500	1500	1500	1500
	Low	1275	–	A	1275	1275	1275	1275	1275	1275	1275	1275	1275	1275	1275
060 – Full Load	Hi	2300	+	A	2300	2300	2300	2300	2300	2300	2300	2300	2300	2300	2300
	Med	2000	Normal	A	2000	2000	2000	2000	2000	2000	2000	2000	2000	2000	2000
	Low	1700	–	A	1700	1700	1700	1700	1700	1700	1700	1700	1700	1700	1700
072 – Part Load	Hi	1850	+	A	1850	1850	1850	1850	1850	1850	1850	1850	1850	1850	1850
	Med	1600	Normal	A	1600	1600	1600	1600	1600	1600	1600	1600	1600	1600	1600
	Low	1500	–	A	1525	1525	1525	1525	1525	1525	1525	1525	1525	1525	1525
072 – Full Load	Hi	2300	+	A	2300	2300	2300	2300	2300	2300	2300	2300	2300	2300	2300
	Med	2200	Normal	A	2250	2250	2250	2250	2250	2250	2250	2250	2250	2250	2250
	Low	1900	–	A	1900	1900	1900	1900	1900	1900	1900	1900	1900	1900	1900

ELECTRICAL DATA

Model	Voltage Code	Rated Voltage	Voltage Min/Max	Compressor			Total Unit w/ Constant CFM Motor		
				QTY	RLA	LRA	FLA	Min Circuit Amps	Max Fuse/HACR
GP024	1	208-230/60/1	197/253	1	11.7	58.3	2.8	17.4	25
GP036	1	208-230/60/1	197/253	1	15.3	83.0	4.3	23.4	35
GP048	1	208-230/60/1	197/253	1	21.2	104.0	6.8	33.3	50
GP060	1	208-230/60/1	197/253	1	27.1	152.9	9.1	43.0	70
GP072	1	208-230/60/1	197/253	1	29.7	179.2	9.1	46.2	70

ELECTRICAL DATA - UNITS W/EH OPTION - COMPRESSOR POWER CONNECTION

Model	Voltage Code	Rated Voltage	Voltage Min/Max	Compressor			Total Unit	
				QTY	RLA	LRA	Min Circuit Amps	Max Fuse/HACR
GP024	1	208-230/60/1	197/253	1	11.7	58.3	14.6	25
GP036	1	208-230/60/1	197/253	1	15.3	83.0	19.1	30
GP048	1	208-230/60/1	197/253	1	21.2	104.0	26.5	45
GP060	1	208-230/60/1	197/253	1	27.1	152.9	33.9	60
GP072	1	208-230/60/1	197/253	1	29.7	179.2	37.1	60

ELECTRICAL DATA - UNITS W/EH - CONSTANT AIRFLOW ECM

Model	EH Rate kW	Stage	Heater Watts		Heater AMPS		Motor FLA (A)	Circuit Fuses	MCA		MOP	
			240	208	240V	208V			240V	208V	240V	208V
GP024	4.8	1	4,800	3,600	20.0	17.3	2.8	-	28.5	25.1	30	30
GP036	4.8	1	4,800	3,600	20.0	17.3	4.3	-	30.4	27.0	35	35
GP036	9.6	1	9,600	7,200	40.0	34.6	4.3	-	55.4	48.6	60	60
GP048	4.8	1	4,800	3,600	20.0	17.3	6.8	-	33.5	30.1	35	35
GP048	9.6	1	9,600	7,200	40.0	34.6	6.8	-	58.5	51.8	60	60
GP048	14.4	2	14400	10800	60	51.9	6.8	F1/F2	83.5	73.4	90	80
								F3/F4				
GP060	4.8	1	4,800	3,600	20.0	17.3	9.1	-	36.4	33.0	40	35
GP060	9.6	1	9,600	7,200	40.0	34.6	9.1	-	61.4	54.6	70	60
GP060	14.4	2	14400	10800	60	51.9	9.1	F1/F2	86.4	76.3	90	80
							9.1	F3/F4				
GP060	19.2	2	19200	14000	80	69.2	9.1	F1/F2	111.4	97.9	125	100
							9.1	F3/F4				
GP072	4.8	1	4,800	3,600	20.0	17.3	9.1	-	36.4	33.0	40	35
GP072	9.6	1	9,600	7,200	40.0	34.6	9.1	-	61.4	54.6	70	60
GP072	14.4	2	14400	10800	60	51.9	9.1	F1/F2	86.4	76.3	90	80
								F3/F4				
GP072	19.2	2	19200	14000	80	69.2	9.1	F1/F2	111.4	97.9	125	100
								F3/F4				

ACCESSORIES

Factory Installed Options

- Cupro-nickel Coil - Recommended in conditions anticipating moderate scale formation or in brackish water.
- Domestic Hot Water Heat Recovery Package: - Used to heat domestic hot water using the wasted heat from the hot compressed gas of the compressor.
- SmartStart: - A factory installed start-up device that improves efficiency as much as 65% and helps reduce wear and tear on the compressor during start-up.

Field Installed Accessories

- Thermostats - Compatible with many 3 heat, 2 cool heat pump thermostats.
- Internal Electric Heat - Choices include 5, 10, 15, or 20 kilowatt back up or an emergency heater depending on the size of the geothermal heat pump.

Motor Profile Air Flow Table CFM 2 Stage Units

MODEL	FAN ONLY	Y1 COOL/HEAT	Y2 COOL/HEAT	AUX HEAT	EMERG HEAT	PLUS ADJ	MINUS ADJ	TAP COOL/HEAT/DELAY
GP024	450	500	800	800	800	900	700	A
GP036	700	800	1200	1200	1200	1400	1000	A
GP048	900	1000	1600	1600	1600	1800	1400	B
GP060	1200	1400	2000	2000	2000	2100	1900	A
GP072	1600	1600	2200	2200	2200	2300	1900	A

DIMENSIONS - VERTICAL

MODEL	A	B	C	D	E	F	G	H	J	K	M	N	P	Q	Condenser Water Connections	Recommended Replacement Nominal Filter Size
	Width	Depth	Height								R/A Duct Fig Width	R/A Duct Fig Height	Filter Rack Height			
GP024, 036	21.50	26.00	47.25	13.75	15.75	6.13	5.25	2.50	8.00	13.50	22.00	22.25	24.00	4.00	3/4" F.P.T.	24 X 24 X 1
GP048	24.00	32.75	47.25	15.75	15.75	8.38	5.50	2.50	8.00	14.75	28.50	22.25	24.00	4.00	1" F.P.T.	24 X 30 X 1
GP060	26.00	33.25	51.25	17.75	17.75	7.13	6.25	2.50	8.00	14.75	28.50	22.25	24.00	4.00	1" F.P.T.	24 X 30 X 1
GP072	26.00	33.25	58.25	17.75	17.75	8.00	7.75	2.50	8.00	14.75	28.50	30.25	32.00	1.50	1" F.P.T.	16 X 30 X 1 (2)

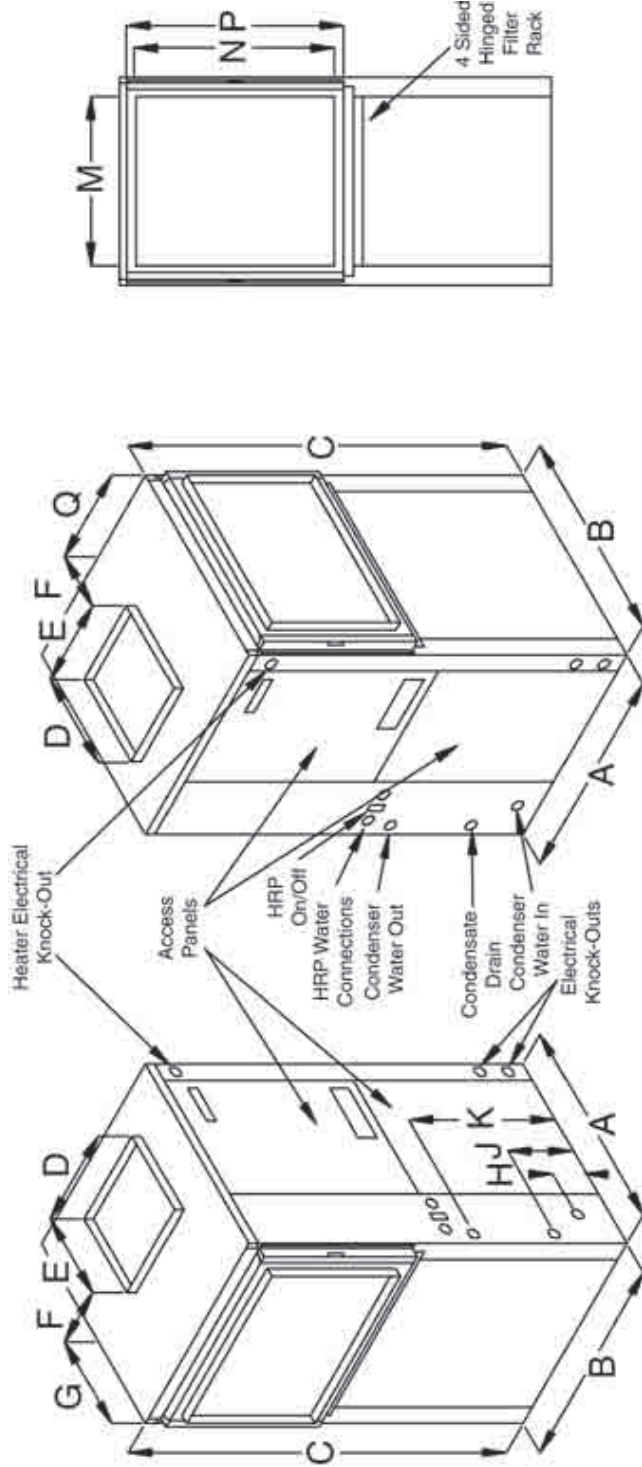

Right Hand Return (FRT)

Left Hand Return (FLT)

NOTES: All dimensions within +/- 0.125".

All condensate drain connections are 3/4" FPT.

All Heat Recovery Kit connections are 1/2" FPT.

Internal electric heat available on 208-230/160 top discharge units only

Internal Heat Recovery Kit available on 208-230 volt units only.

Specifications subject to change without notice.

DIMENSIONS - HORIZONTAL

MODEL	A B C		D	E	F	G	H	J	K	M	N	P	Q	R	T	Condenser Water Connections	Recommended Replacement Nom. Filter Size
	Width	Depth															
GP024, 036	26.00	54.50	21.75	2.00	30.00	22.50	2.50	4.50	13.75	3.00	15.75	4.50	3.00	20.50	18.50	3/4" F.P.T.	18 X 30 X 1 (1)
GP049	30.00	68.00	21.75	2.50	33.50	32.00	2.50	5.81	15.75	3.00	15.75	5.81	2.00	20.50	18.50	1" F.P.T.	18 X 20 X 1 (2)
GP060	30.00	68.00	21.75	2.50	33.50	32.00	2.50	7.66	17.75	2.00	17.75	7.66	2.00	20.50	18.50	1" F.P.T.	18 X 20 X 1 (2)
GP072	30.00	78.00	21.75	2.50	44.00	31.50	2.50	3.50	17.75	2.75	17.75	7.66	1.00	20.25	18.50	1" F.P.T.	20x24x1 (22)

Left Hand Return End Blow (FLE)

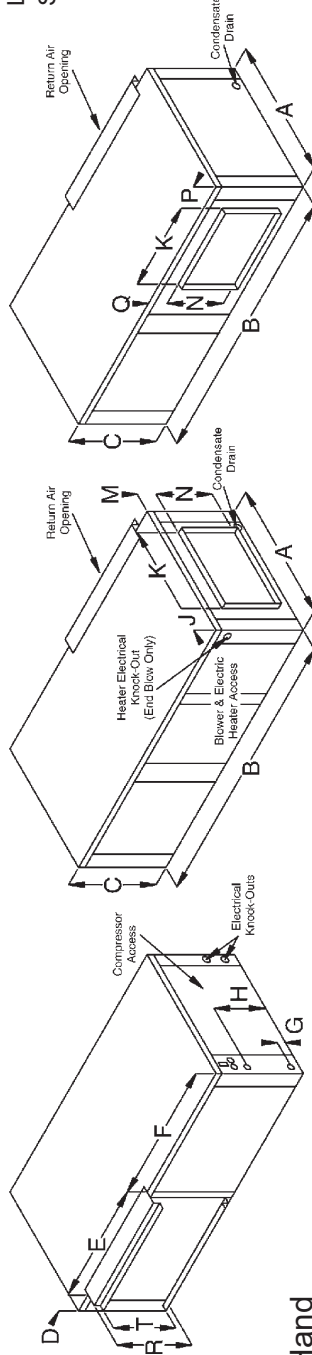

Left Hand Return Straight Through (FLS)

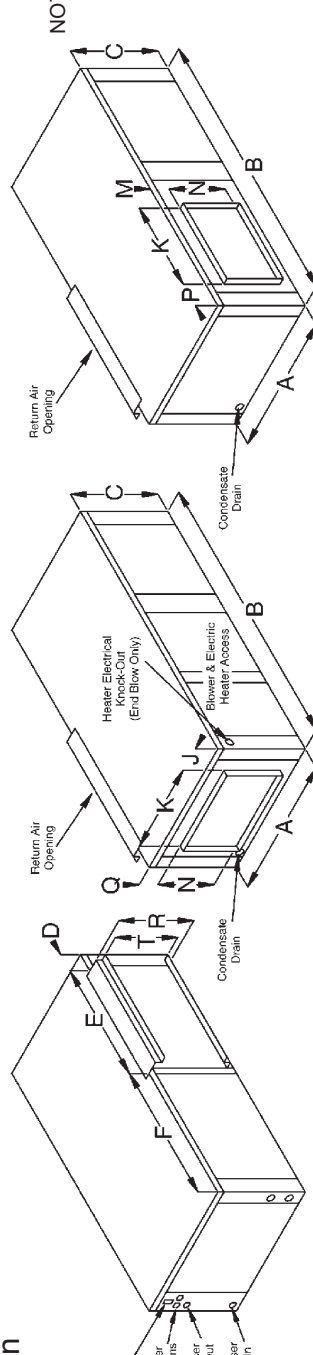

Left Hand Return

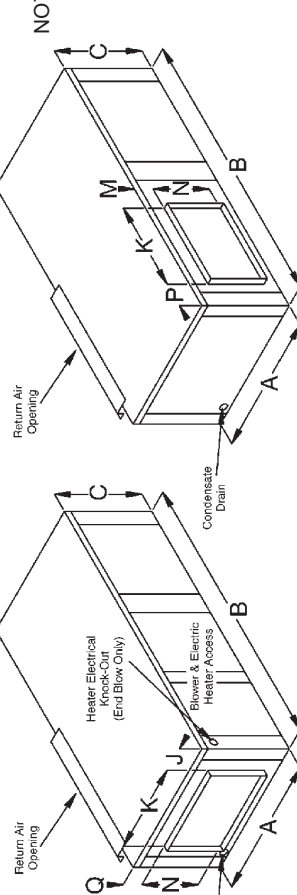

Right Hand Return

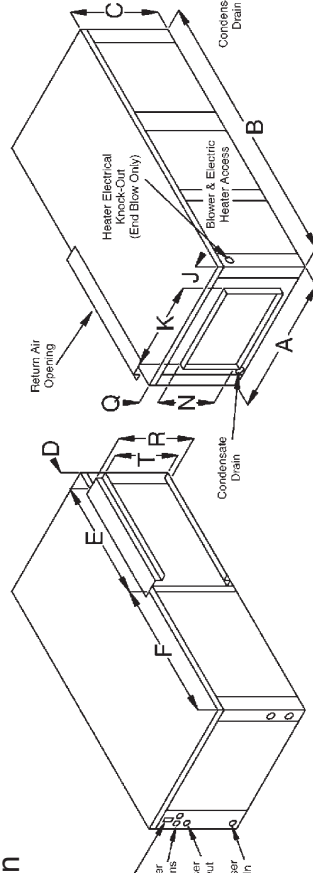

Right Hand Return Straight Through (FRS)

Right Hand Return End Blow (FRE)

NOTES: All dimensions within +/- 0.125".

All condensate drain connections are 3/4" FPT.

All Heat Recovery connections are 1/2" FPT.

Internal electric heat available on 208-230 volt units only

Internal Heat Recovery Kit available on 208-230 volt units only.

Units can be field converted between end blow and straight through supply air configurations.

Specifications subject to change without notice.

DIMENSIONS - COUNTERFLOW

MODEL	A		B	C	D	E	F	G	H	J	K	M	N	P	Condenser Water Connections	Recommended Replacement Nominal Filter Size
	Width	Depth	Height	Blower Opening	Blower Opening	Blower Opening	R/A Duct Fig Width	R/A Duct Fig Height	Filter Rack Height							
GE024, 036	21.50	26.00	47.25	9.25	10.25	6.00	5.50	8.50	19.50	9.75	22.00	22.00	24.00	3/4" F.P.T.	24 X 24 X 1	
GP048	24.00	32.75	47.25	10.75	11.50	11.13	6.88	7.50	18.50	8.75	28.00	22.00	24.00	1" F.P.T.	24 X 30 X 1	
GP060	26.00	33.25	51.25	12.00	12.50	8.38	5.00	9.75	21.75	10.50	28.00	22.00	24.00	1" F.P.T.	24 X 30 X 1	
GP072	26.00	33.25	58.25	12.75	13.50	9.75	4.50	7.00	20.25	11.00	28.00	30.00	32.00	1" F.P.T.	16 X 30 X 1 (2)	

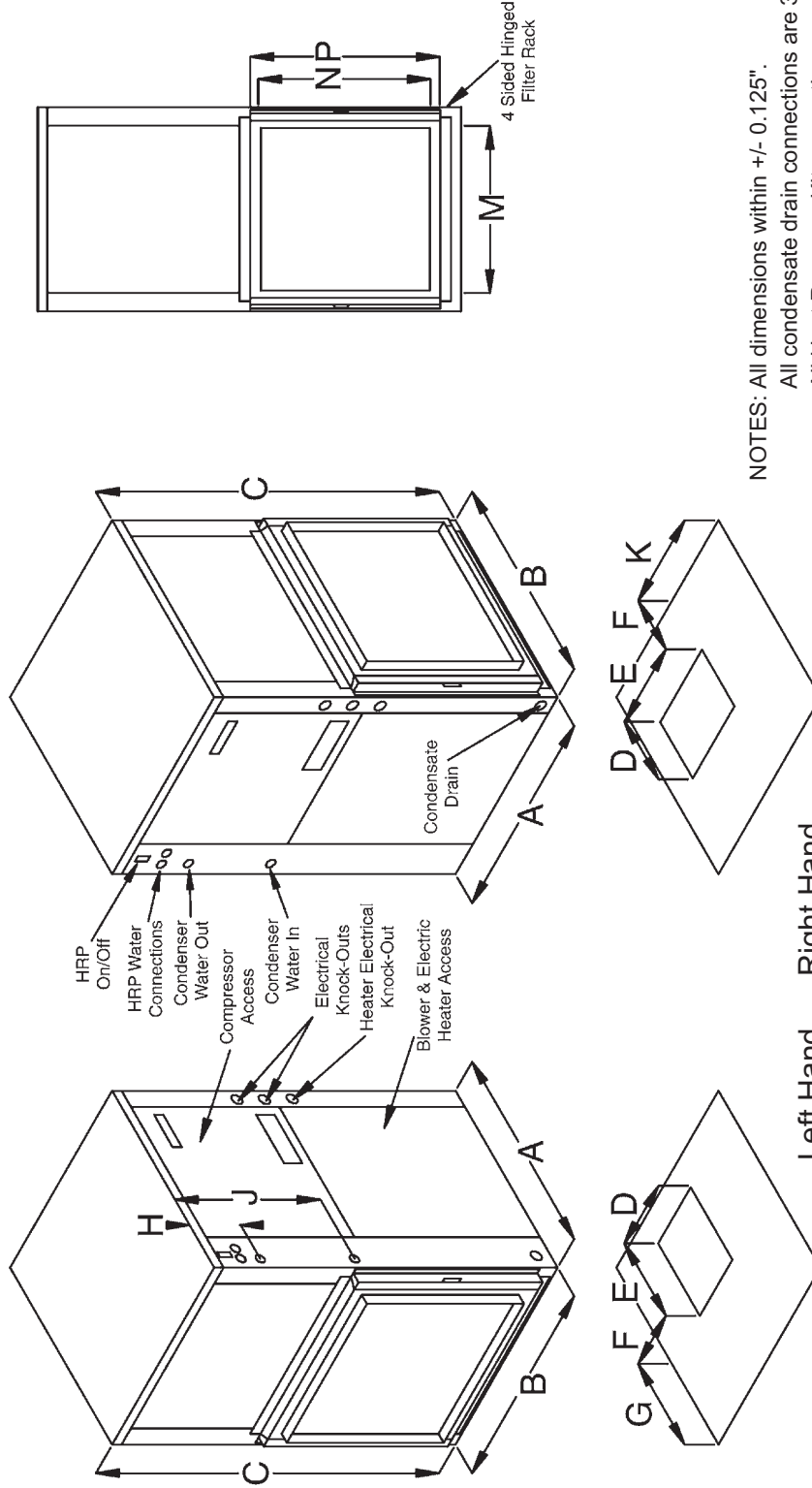

NOTES: All dimensions within +/- 0.125".

All condensate drain connections are 3/4" FPT.

All Heat Recovery Kit connections are 1/2" FPT.

Internal electric heat available on 208-230/1/60 bottom discharge units only

Internal Heat Recovery Kit available on 208-230 volt units only.

Specifications subject to change without notice.

Left Hand Return (FLB)
Right Hand Return (FRB)

GP024 HEATING PERFORMANCE - PART LOAD

GP024 Heating Performance – Part Load @ 600 CFM								
Entering Water, °F	Water flow, GPM	Pressure Drop Ft. Water	Pressure Drop (Psi)	Ent. Air °F	Total kBtu/hr.	Ht. Abs. kBtu/hr.	Unit kW	COP
30	3	1.5	0.7	60	13.5	10.3	0.98	4.0
				70	13.0	9.8	1.12	3.4
				80	12.8	8.7	1.27	3.0
	4	2.5	1.1	60	13.7	10.6	0.98	4.1
				70	13.4	9.9	1.12	3.5
				80	13.2	9.0	1.27	3.0
	6	5.1	2.2	60	14.2	11.0	0.99	4.2
				70	13.7	10.3	1.12	3.6
				80	13.4	9.4	1.28	3.1
40	3	1.4	0.6	60	15.5	12.4	1.00	4.5
				70	15.2	11.5	1.15	3.9
				80	14.7	10.5	1.30	3.3
	4	2.4	1.0	60	15.9	12.7	1.01	4.6
				70	15.5	11.8	1.15	3.9
				80	15.1	11.0	1.31	3.4
	6	4.9	2.1	60	16.5	13.2	1.02	4.7
				70	16.0	12.2	1.16	4.0
				80	15.6	11.2	1.31	3.5
50	3	1.4	0.6	60	17.8	14.5	1.04	5.0
				70	17.4	13.8	1.18	4.3
				80	17.1	12.7	1.34	3.7
	4	2.3	1.0	60	18.3	15.0	1.05	5.1
				70	17.9	14.1	1.19	4.4
				80	17.3	12.9	1.35	3.8
	6	4.7	2.0	60	19.0	15.8	1.06	5.3
				70	18.4	14.6	1.20	4.5
				80	17.9	13.6	1.36	3.9
60	3	1.3	0.6	60	20.4	16.2	1.08	5.6
				70	18.8	16.1	1.19	4.6
				80	19.3	14.8	1.38	4.1
	4	2.2	1.0	60	20.9	17.6	1.09	5.6
				70	20.5	16.3	1.24	4.9
				80	19.6	15.2	1.39	4.1
	6	4.6	2.0	60	21.7	18.4	1.10	5.8
				70	21.1	16.9	1.25	5.0
				80	20.3	15.6	1.40	4.2
70	3	1.3	0.6	60	23.1	20.2	1.13	6.0
				70	22.4	18.3	1.27	5.1
				80	20.5	17.4	1.39	4.3
	4	2.1	0.9	60	23.8	20.4	1.14	6.1
				70	22.9	18.9	1.29	5.2
				80	22.0	17.3	1.44	4.5
	6	4.4	1.9	60	24.5	20.8	1.15	6.2
				70	23.7	19.7	1.30	5.3
				80	22.9	18.0	1.45	4.6
80	3	1.2	0.5	60	25.7	22.8	1.18	6.4
				70	25.0	21.0	1.33	5.5
				80	24.1	19.8	1.48	4.8
	4	2.1	0.9	60	26.8	23.4	1.19	6.6
				70	25.6	21.8	1.34	5.6
				80	24.7	20.0	1.49	4.9
	6	4.3	1.9	60	27.5	24.3	1.21	6.6
				70	26.5	22.4	1.36	5.7
				80	25.2	20.3	1.50	4.9

GP024 HEATING PERFORMANCE - FULL LOAD

GP024 Heating Performance – Full Load @ 900 CFM								
Entering Water, °F	Water flow, GPM	Pressure Drop Ft. Water	Pressure Drop (Psi)	Ent. Air F	Total kBtu/hr.	Ht. Abs. kBtu/hr.	Unit kW	COP
30	3	1.5	0.7	60	19.8	14.7	1.58	3.7
				70	19.5	13.7	1.75	3.3
				80	19.3	12.8	1.95	2.9
	4	2.5	1.1	60	20.5	15.3	1.60	3.8
				70	20.1	14.3	1.77	3.3
				80	19.8	13.3	1.96	3.0
	6	5.1	2.2	60	21.3	16.0	1.61	3.9
				70	20.8	14.9	1.78	3.4
				80	20.4	13.9	1.97	3.0
40	3	1.4	0.6	60	22.4	17.2	1.64	4.0
				70	22.0	16.1	1.81	3.6
				80	21.7	15.2	2.00	3.2
	4	2.4	1.0	60	23.4	18.0	1.66	4.1
				70	23.0	16.9	1.82	3.7
				80	22.4	15.8	2.02	3.2
	6	4.9	2.1	60	24.3	18.9	1.68	4.2
				70	23.8	17.7	1.84	3.8
				80	23.2	16.6	2.04	3.3
50	3	1.4	0.6	60	25.4	19.8	1.70	4.4
				70	25.1	18.8	1.87	3.9
				80	24.6	17.7	2.06	3.5
	4	2.3	1.0	60	26.4	20.8	1.72	4.5
				70	25.9	19.7	1.89	4.0
				80	25.5	18.5	2.09	3.6
	6	4.7	2.0	60	27.6	22.0	1.74	4.6
				70	27.0	20.7	1.92	4.1
				80	26.5	19.4	2.11	3.7
60	3	1.3	0.6	60	28.5	22.6	1.76	4.7
				70	28.0	21.5	1.94	4.2
				80	27.5	20.4	2.14	3.8
	4	2.2	1.0	60	29.8	23.8	1.79	4.9
				70	29.1	22.7	1.97	4.3
				80	28.6	21.3	2.17	3.9
	6	4.6	2.0	60	31.2	25.2	1.82	5.0
				70	30.4	23.9	2.00	4.4
				80	29.8	22.4	2.21	4.0
70	3	1.3	0.6	60	32.3	25.9	1.84	5.1
				70	29.2	22.5	1.97	4.3
				80	30.5	23.1	2.23	4.0
	4	2.1	0.9	60	33.3	27.2	1.86	5.2
				70	32.1	25.7	2.05	4.6
				80	31.8	24.3	2.27	4.1
	6	4.4	1.9	60	35.0	28.7	1.90	5.4
				70	34.0	27.5	2.09	4.8
				80	33.3	25.6	2.30	4.2
80	3	1.2	0.5	60	35.7	29.7	1.92	5.5
				70	34.6	27.6	2.10	4.8
				80	33.8	26.1	2.32	4.3
	4	2.1	0.9	60	37.3	30.7	1.95	5.6
				70	36.4	28.9	2.14	5.0
				80	35.3	27.4	2.36	4.4
	6	4.3	1.9	60	38.6	31.9	1.98	5.7
				70	37.8	30.9	2.19	5.1
				80	37.1	29.0	2.42	4.5

GP024 COOLING PERFORMANCE - PART LOAD

GP024 Cooling Performance - Part Load @ 600 CFM									
Entering Water °F	Water flow GPM	Pressure Drop Ft. Water	Pressure Drop (Psi)	Cooling					
				Ent. Air db/wb,F	Total kBtu/hr.	Sensible kBtu/hr.	Ht. Rej. kBtu/hr.	Unit kW	EER
50	3	1.3	0.6	75/63	21.6	15.9	24.1	0.78	27.9
				80/67	23.1	16.4	25.7	0.78	29.5
				85/71	24.8	16.8	27.4	0.79	31.3
	4	2.2	1.0	75/63	22.0	16.1	24.4	0.73	30.0
				80/67	23.6	16.6	26.0	0.74	32.0
				85/71	25.2	17.0	27.7	0.75	33.9
	6	4.6	2.0	75/63	22.4	16.2	24.6	0.69	32.3
				80/67	24.0	16.8	26.3	0.70	34.6
				85/71	25.7	17.2	28.0	0.70	36.9
60	3	1.3	0.6	75/63	20.6	15.5	23.4	0.90	23.0
				80/67	22.0	16.0	24.9	0.91	24.3
				85/71	23.6	16.4	26.5	0.92	25.8
	4	2.1	0.9	75/63	20.9	15.6	23.6	0.86	24.5
				80/67	22.4	16.1	25.2	0.86	26.0
				85/71	24.0	16.5	26.8	0.87	27.7
	6	4.4	1.9	75/63	21.3	15.8	23.9	0.82	26.2
				80/67	22.8	16.3	25.5	0.82	27.9
				85/71	24.5	16.7	27.2	0.82	29.9
70	3	1.2	0.5	75/63	19.5	15.0	22.6	1.03	19.0
				80/67	20.9	15.5	24.1	1.04	20.2
				85/71	22.3	16.0	25.6	1.05	21.3
	4	2.1	0.9	75/63	19.8	15.1	22.9	0.99	20.1
				80/67	21.3	15.6	24.4	0.99	21.5
				85/71	22.7	16.1	25.9	1.00	22.7
	6	4.3	1.9	75/63	20.1	15.3	23.1	0.95	21.3
				80/67	21.6	15.8	24.6	0.95	22.8
				85/71	23.2	16.2	26.3	0.95	24.4
80	3	1.2	0.5	75/63	18.4	14.5	21.9	1.17	15.7
				80/67	19.7	15.0	23.3	1.18	16.7
				85/71	21.0	15.5	24.7	1.19	17.7
	4	2	0.9	75/63	18.7	14.6	22.1	1.13	16.6
				80/67	20.0	15.2	23.5	1.14	17.6
				85/71	21.5	15.6	25.0	1.14	18.8
	6	4.1	1.8	75/63	19.0	14.8	22.3	1.09	17.5
				80/67	20.4	15.3	23.8	1.09	18.7
				85/71	21.9	15.8	25.3	1.10	20.0
85	3	1.2	0.5	75/63	17.8	14.3	21.6	1.25	14.3
				80/67	19.1	14.8	22.9	1.26	15.2
				85/71	20.4	15.3	24.3	1.27	16.1
	4	2	0.9	75/63	18.1	14.4	21.8	1.21	15.0
				80/67	19.4	14.9	23.1	1.21	16.0
				85/71	20.8	15.4	24.6	1.22	17.1
	6	4.1	1.8	75/63	18.4	14.5	22.0	1.17	15.8
				80/67	19.8	15.1	23.4	1.17	17.0
				85/71	21.2	15.5	24.9	1.17	18.1
90	3	1.2	0.5	75/63	17.2	14.0	21.2	1.33	13.0
				80/67	18.4	14.6	22.5	1.34	13.8
				85/71	19.7	15.0	23.9	1.35	14.7
	4	1.9	0.8	75/63	17.5	14.2	21.4	1.29	13.6
				80/67	18.8	14.7	22.7	1.29	14.6
				85/71	20.2	15.1	24.2	1.30	15.6
	6	4	1.7	75/63	17.8	14.3	21.6	1.25	14.3
				80/67	19.2	14.8	23.0	1.25	15.4
				85/71	20.5	15.3	24.4	1.25	16.4
100	3	1.1	0.5	75/63	16.1	13.6	20.5	1.50	10.7
				80/67	17.2	14.1	21.8	1.51	11.4
				85/71	18.4	14.6	23.0	1.52	12.2
	4	1.9	0.8	75/63	16.4	13.7	20.7	1.46	11.3
				80/67	17.5	14.2	22.0	1.46	12.0
				85/71	18.8	14.7	23.3	1.47	12.8
	6	3.9	1.7	75/63	16.6	13.8	20.9	1.42	11.7
				80/67	17.9	14.3	22.1	1.42	12.6
				85/71	19.2	14.8	23.5	1.42	13.5
110	3	1.1	0.5	75/63	14.9	13.1	19.9	1.69	8.8
				80/67	16.0	13.6	21.1	1.69	9.5
				85/71	17.1	14.1	22.3	1.70	10.1
	4	1.8	0.8	75/63	15.2	13.2	20.0	1.65	9.2
				80/67	16.3	13.7	21.2	1.65	9.9
				85/71	17.5	14.2	22.4	1.65	10.6
	6	3.8	1.6	75/63	15.4	13.3	20.2	1.61	9.6
				80/67	16.6	13.8	21.4	1.61	10.3
				85/71	17.8	14.3	22.6	1.61	11.1

GP024 COOLING PERFORMANCE - FULL LOAD

GP024 Cooling Performance - Full Load @ 900 CFM									
Entering Water °F	Water flow GPM	Pressure Drop Ft. Water	Pressure Drop (Psi)	Cooling					
				Ent. Air db/wb,F	Total kBtu/hr.	Sensible kBtu/hr.	Ht. Rej. kBtu/hr.	Unit kW	EER
50	3	1.3	0.6	75/63	28.1	21.9	32.9	1.49	18.9
				80/67	29.9	22.6	34.8	1.51	19.8
				85/71	31.8	23.2	36.8	1.54	20.7
	4	2.2	1.0	75/63	28.6	22.2	33.3	1.44	19.9
				80/67	30.6	22.9	35.3	1.46	21.1
				85/71	32.5	23.5	37.4	1.47	22.1
	6	4.6	2.0	75/63	29.2	22.4	33.7	1.39	21.0
				80/67	31.2	23.1	35.8	1.40	22.3
				85/71	33.3	23.8	37.9	1.41	23.7
60	3	1.3	0.6	75/63	26.8	21.4	31.9	1.63	16.5
				80/67	28.5	22.1	33.8	1.65	17.3
				85/71	30.4	22.7	35.8	1.68	18.1
	4	2.1	0.9	75/63	27.4	21.6	32.4	1.57	17.5
				80/67	29.2	22.3	34.3	1.59	18.4
				85/71	31.1	22.9	36.3	1.61	19.4
	6	4.4	1.9	75/63	27.9	21.8	32.7	1.51	18.5
				80/67	29.8	22.6	34.7	1.53	19.6
				85/71	31.8	23.2	36.8	1.54	20.7
70	3	1.2	0.5	75/63	25.5	20.9	31.1	1.78	14.3
				80/67	27.2	21.5	32.9	1.81	15.0
				85/71	28.9	22.2	34.8	1.85	15.7
	4	2.1	0.9	75/63	26.0	21.1	31.4	1.72	15.2
				80/67	27.7	21.8	33.3	1.74	15.9
				85/71	29.5	22.4	35.2	1.77	16.7
	6	4.3	1.9	75/63	26.5	21.3	31.8	1.66	16.0
				80/67	28.3	22.0	33.7	1.68	16.9
				85/71	30.2	22.7	35.7	1.70	17.8
80	3	1.2	0.5	75/63	24.2	20.3	30.3	1.96	12.4
				80/67	25.8	21.0	32.1	2.00	12.9
				85/71	27.4	21.7	33.8	2.04	13.5
	4	2	0.9	75/63	24.7	20.5	30.6	1.89	13.1
				80/67	26.3	21.2	32.4	1.92	13.7
				85/71	28.0	21.9	34.2	1.95	14.4
	6	4.1	1.8	75/63	25.1	20.7	30.9	1.83	13.7
				80/67	26.9	21.4	32.7	1.85	14.6
				85/71	28.6	22.1	34.6	1.88	15.3
85	3	1.2	0.5	75/63	23.5	20.0	29.9	2.06	11.4
				80/67	25.1	20.7	31.6	2.10	12.0
				85/71	26.7	21.4	33.4	2.13	12.6
	4	2	0.9	75/63	24.0	20.2	30.2	1.99	12.1
				80/67	25.6	20.9	32.0	2.02	12.7
				85/71	27.3	21.6	33.8	2.05	13.3
	6	4.1	1.8	75/63	24.4	20.4	30.4	1.93	12.7
				80/67	26.1	21.1	32.3	1.95	13.4
				85/71	27.9	21.8	34.1	1.98	14.2
90	3	1.2	0.5	75/63	22.8	19.2	29.5	2.16	10.6
				80/67	24.4	20.5	31.2	2.20	11.1
				85/71	26.0	21.1	33.0	2.24	11.7
	4	1.9	0.8	75/63	23.3	19.9	29.8	2.09	11.2
				80/67	24.9	20.7	31.5	2.13	11.7
				85/71	26.6	21.3	33.4	2.16	12.4
	6	4	1.7	75/63	23.7	20.1	30.0	2.03	11.7
				80/67	25.4	20.9	31.8	2.05	12.4
				85/71	27.1	21.6	33.6	2.08	13.1
100	3	1.1	0.5	75/63	21.5	18.7	28.8	2.38	9.0
				80/67	23.0	19.4	30.5	2.42	9.5
				85/71	24.5	20.7	32.2	2.46	10.0
	4	1.9	0.8	75/63	21.9	18.9	29.0	2.32	9.5
				80/67	23.4	20.1	30.7	2.34	10.0
				85/71	25.1	20.8	32.5	2.38	10.6
	6	3.9	1.7	75/63	22.3	19.0	29.2	2.25	9.9
				80/67	23.9	20.3	31.0	2.27	10.5
				85/71	25.5	21.0	32.7	2.30	11.1
110	3	1.1	0.5	75/63	20.1	18.1	28.2	2.63	7.7
				80/67	21.5	18.7	29.8	2.66	8.1
				85/71	23.0	19.6	31.4	2.70	8.5
	4	1.8	0.8	75/63	20.5	18.2	28.3	2.56	8.0
				80/67	22.0	18.9	30.0	2.59	8.5
				85/71	23.5	19.7	31.7	2.62	9.0
	6	3.8	1.6	75/63	20.8	18.3	28.5	2.50	8.3
				80/67	22.3	19.2	30.2	2.52	8.9
				85/71	24.0	20.4	31.9	2.55	9.4

GP036 HEATING PERFORMANCE - PART LOAD

GP036 Heating Performance – Part Load @ 1050 CFM								
Entering Water, °F	Water flow, GPM	Pressure Drop Ft. Water	Pressure Drop (Psi)	Ent. Air F	Total kBtu/hr.	Ht. Abs. kBtu/hr.	Unit kW	COP
30	4.5	3	1.3	60	18.3	13.7	1.44	3.7
				70	17.9	12.7	1.62	3.2
				80	17.6	11.7	1.83	2.8
	6	5	2.2	60	18.8	14.2	1.44	3.8
				70	18.4	13.1	1.63	3.3
				80	18.0	12.0	1.84	2.9
	9	10.4	4.5	60	19.4	14.7	1.45	3.9
				70	18.9	13.6	1.64	3.4
				80	18.4	12.5	1.85	2.9
40	4.5	2.9	1.3	60	21.7	16.9	1.49	4.3
				70	21.2	15.8	1.68	3.7
				80	20.8	14.7	1.89	3.2
	6	4.9	2.1	60	22.4	17.5	1.50	4.4
				70	21.9	16.3	1.69	3.8
				80	21.4	15.2	1.90	3.3
	9	10.1	4.4	60	23.1	18.2	1.51	4.5
				70	22.5	17.0	1.70	3.9
				80	22.0	15.7	1.92	3.4
50	4.5	2.8	1.2	60	25.4	20.3	1.55	4.8
				70	24.8	19.1	1.75	4.2
				80	24.4	17.8	1.97	3.6
	6	4.7	2.0	60	26.2	21.1	1.57	4.9
				70	25.6	19.8	1.76	4.3
				80	25.1	18.5	1.98	3.7
	9	9.7	4.2	60	27.2	22.0	1.58	5.0
				70	26.5	20.6	1.78	4.4
				80	25.9	19.3	2.00	3.8
60	4.5	2.7	1.2	60	29.3	24.0	1.63	5.3
				70	28.6	22.6	1.83	4.6
				80	28.1	21.3	2.06	4.0
	6	4.5	2.0	60	30.3	25.0	1.65	5.4
				70	29.6	23.5	1.85	4.7
				80	29.0	22.1	2.08	4.1
	9	9.4	4.1	60	31.5	26.0	1.67	5.5
				70	30.7	24.5	1.87	4.8
				80	29.9	23.0	2.10	4.2
70	4.5	2.6	1.1	60	33.5	27.9	1.71	5.7
				70	32.6	26.3	1.92	5.0
				80	32.0	24.8	2.15	4.4
	6	4.4	1.9	60	34.7	29.0	1.73	5.9
				70	33.8	27.4	1.95	5.1
				80	33.0	25.8	2.18	4.4
	9	9.1	3.9	60	36.1	30.4	1.75	6.0
				70	35.2	28.6	1.97	5.2
				80	34.2	26.9	2.21	4.5
80	4.5	2.5	1.1	60	37.7	31.9	1.78	6.2
				70	36.9	30.2	1.99	5.4
				80	36.1	28.5	2.24	4.7
	6	4.2	1.8	60	39.3	33.4	1.81	6.4
				70	38.3	31.6	2.02	5.6
				80	37.4	29.8	2.26	4.8
	9	8.8	3.8	60	40.9	35.2	1.84	6.5
				70	39.8	33.1	2.05	5.7
				80	38.8	31.1	2.29	5.0

GP036 HEATING PERFORMANCE - FULL LOAD

GP036 Heating Performance – Full Load @ 1225 CFM								
Entering Water, °F	Water flow, GPM	Pressure Drop Ft. Water	Pressure Drop (Psi)	Ent. Air F	Total kBtu/hr.	Ht. Abs. kBtu/hr.	Unit kW	COP
30	4.5	3	1.3	60	26.7	19.6	2.24	3.5
				70	26.3	18.4	2.45	3.1
				80	25.7	17.1	2.68	2.8
	6	5	2.2	60	27.6	20.3	2.25	3.6
				70	27.0	19.1	2.47	3.2
				80	26.4	17.8	2.70	2.9
	9	10.4	4.5	60	28.5	21.2	2.27	3.7
				70	27.9	19.8	2.48	3.3
				80	27.3	18.5	2.71	3.0
40	4.5	2.9	1.3	60	30.7	23.2	2.31	3.9
				70	30.2	21.9	2.53	3.5
				80	29.7	20.6	2.77	3.1
	6	4.9	2.1	60	31.8	24.2	2.33	4.0
				70	31.1	22.8	2.55	3.6
				80	30.6	21.4	2.79	3.2
	9	10.1	4.4	60	32.9	25.3	2.35	4.1
				70	32.2	23.8	2.58	3.7
				80	31.5	22.3	2.82	3.3
50	4.5	2.8	1.2	60	35.0	27.1	2.40	4.3
				70	34.3	25.7	2.63	3.8
				80	33.6	24.3	2.87	3.4
	6	4.7	2.0	60	36.3	28.4	2.42	4.4
				70	35.5	26.8	2.65	3.9
				80	34.7	25.3	2.90	3.5
	9	9.7	4.2	60	37.7	29.7	2.45	4.5
				70	36.9	28.1	2.69	4.0
				80	36.0	26.4	2.94	3.6
60	4.5	2.7	1.2	60	39.6	31.4	2.48	4.7
				70	38.8	29.8	2.72	4.2
				80	38.1	28.2	2.99	3.7
	6	4.5	2.0	60	41.1	33.0	2.51	4.8
				70	40.3	31.3	2.75	4.3
				80	39.5	29.5	3.02	3.8
	9	9.4	4.1	60	42.9	34.7	2.55	4.9
				70	42.0	32.8	2.78	4.4
				80	41.0	30.9	3.05	3.9
70	4.5	2.6	1.1	60	44.4	36.0	2.57	5.1
				70	43.4	34.4	2.81	4.5
				80	42.7	32.5	3.08	4.1
	6	4.4	1.9	60	46.3	37.8	2.61	5.2
				70	45.3	36.0	2.85	4.7
				80	44.4	34.1	3.12	4.2
	9	9.1	3.9	60	48.5	39.8	2.66	5.4
				70	47.3	37.9	2.89	4.8
				80	46.2	35.8	3.16	4.3
80	4.5	2.5	1.1	60	49.5	40.8	2.68	5.4
				70	48.5	38.9	2.92	4.9
				80	47.6	37.0	3.19	4.4
	6	4.2	1.8	60	51.7	42.8	2.73	5.6
				70	50.6	40.8	2.97	5.0
				80	49.5	38.8	3.24	4.5
	9	8.8	3.8	60	54.3	45.2	2.78	5.7
				70	52.9	43.0	3.03	5.1
				80	51.6	40.8	3.30	4.6

GP036 COOLING PERFORMANCE - PART LOAD

GP036 Cooling Performance - Part Load @ 1050 CFM									
Entering Water °F	Water flow GPM	Pressure Drop Ft. Water	Pressure Drop (Psi)	Cooling					
				Ent. Air db/wb,F	Total kBtu/hr.	Sensible kBtu/hr.	Ht. Rej. kBtu/hr.	Unit kW	EER
50	4.5	2.7	1.2	75/63	28.3	23.7	32.3	1.22	23.1
				80/67	30.5	24.6	34.5	1.25	24.4
				85/71	32.6	25.4	36.8	1.28	25.4
	6	4.5	2.0	75/63	28.8	23.9	32.6	1.18	24.4
				80/67	30.9	24.8	34.9	1.20	25.7
				85/71	33.1	25.6	37.2	1.23	26.9
	9	9.4	4.1	75/63	29.2	24.1	32.9	1.13	25.8
				80/67	31.4	25.0	35.2	1.15	27.2
				85/71	33.7	25.8	37.6	1.18	28.6
60	4.5	2.6	1.1	75/63	26.9	23.1	31.3	1.38	19.5
				80/67	29.0	24.0	33.5	1.40	20.7
				85/71	31.0	24.9	35.7	1.43	21.7
	6	4.4	1.9	75/63	27.3	23.3	31.6	1.33	20.5
				80/67	29.4	24.2	33.8	1.35	21.7
				85/71	31.5	25.1	36.0	1.38	22.9
	9	9.1	3.9	75/63	27.8	23.5	31.9	1.29	21.6
				80/67	29.9	24.4	34.1	1.31	22.9
				85/71	32.1	25.3	36.4	1.33	24.1
70	4.5	2.5	1.1	75/63	25.5	22.5	30.4	1.54	16.6
				80/67	27.4	23.5	32.4	1.56	17.5
				85/71	29.4	24.4	34.5	1.59	18.5
	6	4.2	1.8	75/63	25.9	22.7	30.6	1.49	17.3
				80/67	27.9	23.7	32.7	1.52	18.4
				85/71	29.9	24.6	34.9	1.54	19.4
	9	8.8	3.8	75/63	26.3	22.9	30.9	1.45	18.1
				80/67	28.3	23.8	33.0	1.47	19.3
				85/71	30.4	24.7	35.2	1.49	20.4
80	4.5	2.4	1.0	75/63	24.0	21.9	29.4	1.72	13.9
				80/67	25.9	22.9	31.4	1.74	14.8
				85/71	27.8	23.8	33.4	1.77	15.7
	6	4.1	1.8	75/63	24.4	22.1	29.6	1.67	14.6
				80/67	26.3	23.1	31.6	1.69	15.5
				85/71	28.2	24.0	33.7	1.71	16.4
	9	8.5	3.7	75/63	24.7	22.3	29.8	1.63	15.2
				80/67	26.7	23.2	31.9	1.64	16.2
				85/71	28.8	24.1	34.1	1.66	17.3
85	4.5	2.4	1.0	75/63	23.3	21.7	28.9	1.82	12.8
				80/67	25.1	22.6	30.9	1.84	13.6
				85/71	27.0	23.5	32.9	1.87	14.4
	6	4	1.7	75/63	23.6	21.8	29.1	1.77	13.3
				80/67	25.5	22.7	31.1	1.79	14.2
				85/71	27.4	23.7	33.2	1.81	15.1
	9	8.4	3.6	75/63	24.0	21.9	29.4	1.73	13.9
				80/67	25.9	22.9	31.4	1.74	14.9
				85/71	27.9	23.8	33.5	1.76	15.9
90	4.5	2.4	1.0	75/63	22.5	21.4	28.5	1.93	11.7
				80/67	24.3	22.4	30.4	1.95	12.5
				85/71	26.2	23.3	32.4	1.97	13.3
	6	4	1.7	75/63	22.8	21.5	28.7	1.88	12.1
				80/67	24.7	22.5	30.6	1.90	13.0
				85/71	26.6	23.4	32.6	1.91	13.9
	9	8.2	3.6	75/63	23.2	21.6	28.9	1.83	12.7
				80/67	25.1	22.6	30.9	1.85	13.6
				85/71	27.0	23.5	32.9	1.86	14.5
100	4.5	2.3	1.0	75/63	21.1	20.1	27.7	2.17	9.7
				80/67	22.8	21.8	29.5	2.18	10.4
				85/71	24.6	22.7	31.4	2.20	11.2
	6	3.8	1.6	75/63	21.4	20.3	27.9	2.11	10.1
				80/67	23.1	21.9	29.7	2.13	10.9
				85/71	24.9	22.9	31.6	2.14	11.6
	9	8	3.5	75/63	21.7	20.4	28.0	2.06	10.5
				80/67	23.5	22.0	29.9	2.07	11.3
				85/71	25.3	23.0	31.9	2.08	12.2
110	4.5	2.2	1.0	75/63	19.6	19.4	27.1	2.44	8.0
				80/67	21.2	20.5	28.8	2.45	8.7
				85/71	22.9	21.6	30.6	2.46	9.3
	6	3.7	1.6	75/63	19.9	19.6	27.2	2.38	8.4
				80/67	21.6	20.6	29.0	2.39	9.0
				85/71	23.3	22.3	30.8	2.40	9.7
	9	7.8	3.4	75/63	20.2	19.7	27.3	2.33	8.7
				80/67	21.9	20.7	29.1	2.33	9.4
				85/71	23.6	22.4	30.9	2.34	10.1

GP036 COOLING PERFORMANCE - FULL LOAD

GP036 Cooling Performance – Full Load @ 1225 CFM									
Entering Water °F	Water flow GPM	Pressure Drop Ft. Water	Pressure Drop (Psi)	Cooling					
				Ent. Air db/wb,F	Total kBTu/hr.	Sensible kBTu/hr.	Ht. Rej. kBTu/hr.	Unit kW	EER
50	4.5	2.7	1.2	75/63	39.2	30.1	45.9	2.08	18.9
				80/67	41.9	31.0	48.8	2.10	19.9
				85/71	44.8	31.9	51.8	2.14	21.0
	6	4.5	2.0	75/63	39.9	30.4	46.4	2.00	20.0
				80/67	42.8	31.3	49.4	2.02	21.2
				85/71	45.7	32.3	52.4	2.04	22.3
	9	9.4	4.1	75/63	40.7	30.7	46.9	1.92	21.2
				80/67	43.6	31.7	50.0	1.93	22.5
				85/71	46.6	32.7	53.1	1.95	23.9
60	4.5	2.6	1.1	75/63	37.4	29.3	44.7	2.27	16.5
				80/67	40.1	30.3	47.5	2.30	17.4
				85/71	42.8	31.1	50.4	2.33	18.4
	6	4.4	1.9	75/63	38.1	29.6	45.2	2.19	17.4
				80/67	40.9	30.6	48.1	2.21	18.5
				85/71	43.7	31.5	51.0	2.24	19.5
	9	9.1	3.9	75/63	38.9	29.9	45.7	2.11	18.4
				80/67	41.7	30.9	48.6	2.13	19.6
				85/71	44.6	31.8	51.7	2.15	20.7
70	4.5	2.5	1.1	75/63	35.6	27.8	43.5	2.48	14.4
				80/67	38.1	29.6	46.2	2.50	15.2
				85/71	40.7	30.5	48.9	2.53	16.1
	6	4.2	1.8	75/63	36.3	28.1	44.0	2.40	15.1
				80/67	38.9	29.9	46.7	2.42	16.1
				85/71	41.6	30.8	49.5	2.44	17.0
	9	8.8	3.8	75/63	37.0	28.4	44.4	2.32	15.9
				80/67	39.6	30.2	47.2	2.34	16.9
				85/71	42.5	31.2	50.1	2.35	18.1
80	4.5	2.4	1.0	75/63	33.6	27.1	42.2	2.70	12.4
				80/67	36.2	28.7	44.9	2.73	13.2
				85/71	38.7	29.7	47.5	2.76	14.0
	6	4.1	1.8	75/63	34.3	27.4	42.6	2.62	13.1
				80/67	36.8	29.1	45.3	2.64	13.9
				85/71	39.4	30.1	48.0	2.66	14.8
	9	8.5	3.7	75/63	35.0	27.5	43.1	2.55	13.7
				80/67	37.6	29.3	45.9	2.56	14.7
				85/71	40.3	30.4	48.6	2.57	15.6
85	4.5	2.4	1.0	75/63	32.7	26.7	41.7	2.82	11.6
				80/67	35.1	28.4	44.2	2.85	12.3
				85/71	37.5	29.4	46.8	2.88	13.0
	6	4	1.7	75/63	33.3	27.0	42.0	2.74	12.1
				80/67	35.8	28.1	44.6	2.76	13.0
				85/71	38.4	29.7	47.3	2.78	13.8
	9	8.4	3.6	75/63	34.0	27.1	42.5	2.67	12.7
				80/67	36.5	29.0	45.1	2.68	13.6
				85/71	39.2	29.9	47.9	2.70	14.5
90	4.5	2.4	1.0	75/63	31.8	26.2	41.1	2.95	10.8
				80/67	34.1	27.2	43.6	2.98	11.4
				85/71	36.5	29.0	46.1	3.01	12.1
	6	4	1.7	75/63	32.4	26.6	41.4	2.87	11.3
				80/67	34.8	28.2	44.0	2.89	12.0
				85/71	37.3	29.3	46.7	2.91	12.8
	9	8.2	3.6	75/63	32.9	26.8	41.8	2.79	11.8
				80/67	35.5	27.7	44.5	2.81	12.6
				85/71	38.1	29.5	47.2	2.82	13.5
100	4.5	2.3	1.0	75/63	29.9	25.3	40.1	3.22	9.3
				80/67	32.1	26.5	42.4	3.25	9.9
				85/71	34.4	27.4	44.9	3.29	10.5
	6	3.8	1.6	75/63	30.5	25.6	40.4	3.14	9.7
				80/67	32.7	26.8	42.7	3.16	10.3
				85/71	35.1	27.8	45.2	3.19	11.0
	9	8	3.5	75/63	31.0	25.7	40.7	3.07	10.1
				80/67	33.3	27.0	43.1	3.08	10.8
				85/71	35.8	28.8	45.7	3.10	11.6
110	4.5	2.2	1.0	75/63	28.0	24.5	39.1	3.52	7.9
				80/67	30.0	25.7	41.3	3.56	8.4
				85/71	32.3	26.5	43.7	3.60	9.0
	6	3.7	1.6	75/63	28.5	24.7	39.4	3.44	8.3
				80/67	30.7	25.8	41.7	3.47	8.8
				85/71	32.9	26.8	44.1	3.49	9.4
	9	7.8	3.4	75/63	29.0	24.9	39.6	3.37	8.6
				80/67	31.2	26.1	41.9	3.38	9.2
				85/71	33.5	27.0	44.4	3.41	9.8

GP048 HEATING PERFORMANCE - PART LOAD

GP048 Heating Performance – Part Load @ 1100 CFM								
Entering Water, °F	Water flow, GPM	Pressure Drop Ft. Water	Pressure Drop (Psi)	Ent. Air F	Total kBtu/hr.	Ht. Abs. kBtu/hr.	Unit kW	COP
30	6	3.5	1.5	60	26.4	19.6	2.06	3.8
				70	25.7	18.1	2.29	3.3
				80	25.1	16.5	2.55	2.9
	8	5.8	2.5	60	27.1	20.2	2.07	3.8
				70	26.1	18.7	2.30	3.3
				80	25.7	17.0	2.56	2.9
	12	12.1	5.3	60	27.7	21.0	2.08	3.9
				70	26.8	19.3	2.31	3.4
				80	26.1	17.5	2.57	3.0
40	6	3.4	1.5	60	29.8	22.8	2.10	4.2
				70	29.0	21.3	2.34	3.6
				80	28.4	19.7	2.61	3.2
	8	5.6	2.4	60	30.6	23.6	2.11	4.2
				70	29.8	22.0	2.35	3.7
				80	29.1	20.4	2.62	3.3
	12	11.7	5.1	60	31.5	24.5	2.12	4.4
				70	30.5	22.9	2.36	3.8
				80	29.7	21.1	2.63	3.3
50	6	3.2	1.4	60	33.5	26.4	2.14	4.6
				70	32.7	24.8	2.39	4.0
				80	32.1	23.0	2.67	3.5
	8	5.4	2.3	60	34.5	27.4	2.15	4.7
				70	33.6	25.6	2.40	4.1
				80	32.9	23.9	2.68	3.6
	12	11.3	4.9	60	35.6	28.5	2.16	4.8
				70	34.6	26.7	2.41	4.2
				80	33.8	24.8	2.70	3.7
60	6	3.1	1.3	60	37.5	30.3	2.17	5.1
				70	36.7	28.6	2.42	4.4
				80	36.0	26.8	2.71	3.9
	8	5.2	2.3	60	38.7	31.5	2.17	5.2
				70	37.8	29.7	2.42	4.6
				80	37.0	27.8	2.71	4.0
	12	10.9	4.7	60	40.1	32.9	2.18	5.4
				70	39.0	30.9	2.43	4.7
				80	37.9	29.0	2.71	4.1
70	6	3	1.3	60	41.7	34.5	2.18	5.6
				70	40.8	32.7	2.43	4.9
				80	40.0	30.7	2.72	4.3
	8	5.1	2.2	60	43.1	35.9	2.18	5.8
				70	42.1	34.0	2.43	5.1
				80	41.1	32.0	2.72	4.4
	12	10.5	4.6	60	44.7	37.5	2.17	6.0
				70	43.5	35.4	2.43	5.2
				80	42.4	33.3	2.72	4.6
80	6	2.9	1.3	60	46.0	38.9	2.17	6.2
				70	44.9	36.9	2.43	5.4
				80	43.9	35.0	2.72	4.7
	8	4.9	2.1	60	47.6	40.5	2.16	6.5
				70	46.4	38.4	2.42	5.6
				80	45.4	36.3	2.71	4.9
	12	10.2	4.4	60	49.4	42.3	2.14	6.8
				70	48.0	40.0	2.41	5.8
				80	46.7	37.7	2.70	5.1

GP048 HEATING PERFORMANCE - FULL LOAD

GP048 Heating Performance – Full Load @ 1700 CFM								
Entering Water, °F	Water flow, GPM	Pressure Drop Ft. Water	Pressure Drop (Psi)	Ent. Air °F	Total kBtu/hr.	Ht. Abs. kBtu/hr.	Unit kW	COP
30	6	3.5	1.5	60	34.5	24.7	2.96	3.4
				70	34.1	23.4	3.22	3.1
				80	33.8	22.1	3.50	2.8
	8	5.8	2.5	60	35.8	26.0	2.99	3.5
				70	35.4	24.5	3.25	3.2
				80	35.0	23.2	3.53	2.9
	12	12.1	5.3	60	37.3	27.3	3.03	3.6
				70	36.8	26.0	3.29	3.3
				80	36.3	24.5	3.57	3.0
40	6	3.4	1.5	60	39.0	28.9	3.07	3.7
				70	38.6	27.5	3.33	3.4
				80	38.1	26.1	3.62	3.1
	8	5.6	2.4	60	40.7	30.2	3.11	3.8
				70	40.1	28.7	3.37	3.5
				80	39.6	27.2	3.65	3.2
	12	11.7	5.1	60	42.6	32.0	3.15	4.0
				70	41.8	30.6	3.41	3.6
				80	41.3	29.0	3.69	3.3
50	6	3.2	1.4	60	44.1	33.4	3.18	4.1
				70	43.3	32.0	3.44	3.7
				80	42.8	30.5	3.73	3.4
	8	5.4	2.3	60	45.9	35.3	3.23	4.2
				70	45.2	33.7	3.48	3.8
				80	44.6	31.9	3.77	3.5
	12	11.3	4.9	60	48.3	37.6	3.28	4.3
				70	47.7	35.7	3.53	4.0
				80	46.6	34.0	3.82	3.6
60	6	3.1	1.3	60	49.2	38.5	3.29	4.4
				70	48.5	36.8	3.56	4.0
				80	47.9	35.2	3.85	3.6
	8	5.2	2.3	60	51.6	40.8	3.34	4.5
				70	50.9	39.0	3.61	4.1
				80	50.0	37.1	3.90	3.8
	12	10.9	4.7	60	54.4	43.4	3.40	4.7
				70	53.6	41.0	3.66	4.3
				80	52.4	38.8	3.96	3.9
70	6	3	1.3	60	54.6	43.4	3.41	4.7
				70	54.1	41.7	3.67	4.3
				80	53.2	40.1	3.98	3.9
	8	5.1	2.2	60	57.6	46.5	3.46	4.9
				70	56.6	44.4	3.73	4.4
				80	55.7	42.1	4.03	4.0
	12	10.5	4.6	60	60.9	49.6	3.52	5.1
				70	59.7	47.2	3.79	4.6
				80	58.8	44.7	4.10	4.2
80	6	2.9	1.3	60	60.8	49.4	3.52	5.1
				70	59.5	46.8	3.79	4.6
				80	58.6	45.2	4.10	4.2
	8	4.9	2.1	60	64.0	51.8	3.58	5.2
				70	62.6	50.2	3.86	4.8
				80	61.5	47.8	4.17	4.3
	12	10.2	4.4	60	67.7	56.0	3.65	5.4
				70	66.2	53.5	3.92	4.9
				80	64.8	50.9	4.24	4.5

GP048 COOLING PERFORMANCE - PART LOAD

GP048 Cooling Performance – Part Load @ 1100 CFM									
Entering Water °F	Water flow GPM	Pressure Drop Ft. Water	Pressure Drop (Psi)	Cooling					
				Ent. Air db/wb,F	Total kBtu/hr.	Sensible kBtu/hr.	Ht. Rej. kBtu/hr.	Unit kW	EER
50	6	3.1	1.3	75/63	36.5	27.7	41.7	1.62	22.6
				80/67	38.8	28.6	43.9	1.60	24.3
				85/71	41.3	29.2	46.4	1.58	26.2
	8	5.2	2.3	75/63	37.1	28.0	42.1	1.55	23.9
				80/67	39.5	28.8	44.4	1.53	25.8
				85/71	42.1	29.5	47.0	1.50	28.1
	12	10.9	4.7	75/63	37.8	28.4	42.6	1.49	25.4
				80/67	40.2	29.2	45.0	1.46	27.5
				85/71	42.9	29.9	47.6	1.43	30.1
60	6	3	1.3	75/63	34.7	27.0	40.4	1.80	19.3
				80/67	37.0	27.8	42.7	1.78	20.7
				85/71	39.3	28.6	45.0	1.76	22.3
	8	5.1	2.2	75/63	35.3	27.3	40.9	1.73	20.3
				80/67	37.6	28.1	43.1	1.71	21.9
				85/71	40.0	28.9	45.5	1.69	23.7
	12	10.5	4.6	75/63	36.0	27.6	41.3	1.67	21.6
				80/67	38.3	28.4	43.6	1.64	23.3
				85/71	40.9	29.1	46.1	1.61	25.4
70	6	2.9	1.3	75/63	32.9	26.3	39.3	2.01	16.4
				80/67	35.1	27.1	41.4	1.99	17.6
				85/71	37.4	27.9	43.7	1.97	19.0
	8	4.9	2.1	75/63	33.5	26.5	39.6	1.94	17.3
				80/67	35.7	27.4	41.8	1.92	18.6
				85/71	38.1	28.1	44.2	1.89	20.1
	12	10.2	4.4	75/63	34.1	26.8	40.0	1.87	18.2
				80/67	36.4	27.6	42.3	1.84	19.7
				85/71	38.9	28.4	44.7	1.81	21.5
80	6	2.8	1.2	75/63	31.1	24.9	38.1	2.25	13.8
				80/67	33.2	26.4	40.2	2.23	14.9
				85/71	35.4	27.1	42.4	2.21	16.0
	8	4.7	2.0	75/63	31.6	25.2	38.4	2.17	14.5
				80/67	33.8	26.6	40.6	2.15	15.7
				85/71	36.0	27.5	42.8	2.13	16.9
	12	9.8	4.3	75/63	32.2	26.0	38.8	2.10	15.3
				80/67	34.4	26.9	41.0	2.07	16.6
				85/71	36.7	27.7	43.2	2.04	18.0
85	6	2.8	1.2	75/63	30.2	24.4	37.6	2.38	12.7
				80/67	32.2	26.0	39.7	2.36	13.6
				85/71	34.3	26.9	41.7	2.34	14.6
	8	4.7	2.0	75/63	30.7	24.8	37.9	2.30	13.3
				80/67	32.8	26.2	40.0	2.28	14.4
				85/71	35.0	27.1	42.1	2.26	15.5
	12	9.7	4.2	75/63	31.3	24.9	38.2	2.23	14.1
				80/67	33.4	26.5	40.3	2.20	15.2
				85/71	35.7	27.2	42.6	2.17	16.4
90	6	2.7	1.2	75/63	29.2	24.0	37.1	2.52	11.6
				80/67	31.3	25.6	39.1	2.50	12.5
				85/71	33.4	26.4	41.2	2.48	13.5
	8	4.6	2.0	75/63	29.7	24.2	37.4	2.44	12.2
				80/67	31.8	25.9	39.4	2.42	13.1
				85/71	34.0	26.7	41.6	2.39	14.2
	12	9.5	4.1	75/63	30.3	24.5	37.7	2.36	12.8
				80/67	32.4	26.1	39.7	2.34	13.9
				85/71	34.6	27.0	41.9	2.31	15.0
100	6	2.7	1.2	75/63	27.4	23.1	36.2	2.83	9.7
				80/67	29.3	24.0	38.1	2.81	10.4
				85/71	31.4	25.0	40.1	2.78	11.3
	8	4.5	2.0	75/63	27.8	23.4	36.4	2.75	10.1
				80/67	29.8	24.4	38.3	2.73	10.9
				85/71	31.9	25.4	40.4	2.69	11.9
	12	9.2	4.0	75/63	28.3	23.6	36.7	2.67	10.6
				80/67	30.4	24.5	38.6	2.64	11.5
				85/71	32.5	26.2	40.7	2.60	12.5
110	6	2.6	1.1	75/63	25.5	22.3	35.4	3.19	8.0
				80/67	27.4	23.3	37.3	3.16	8.7
				85/71	29.4	24.2	39.2	3.12	9.4
	8	4.3	1.9	75/63	25.9	22.5	35.6	3.11	8.3
				80/67	27.9	23.5	37.5	3.07	9.1
				85/71	29.9	24.5	39.4	3.02	9.9
	12	9	3.9	75/63	26.3	22.7	35.7	3.02	8.7
				80/67	28.4	23.7	37.7	2.98	9.5
				85/71	30.4	24.7	39.6	2.93	10.4

GP048 COOLING PERFORMANCE - FULL LOAD

GP048 Cooling performance – Full Load @ 1600 CFM									
Entering Water °F	Water flow GPM	Pressure Drop Ft. Water	Pressure Drop (Psi)	Cooling					
				Ent. Air db/wb, °F	Total Btu/hr.	Sensible Btu/hr.	Ht. Rej. Btu/hr.	Unit kW	EER
50	6	2.6	1.1	75/63	52.3	40.1	60.4	2.48	21.1
				80/67	55.6	41.3	63.9	2.50	22.2
				85/71	59.2	42.3	67.6	2.53	23.4
	8	4.4	1.9	75/63	53.6	40.6	61.4	2.36	22.7
				80/67	57.1	41.8	64.9	2.38	24.0
				85/71	60.8	42.8	68.8	2.40	25.3
	12	9.1	3.9	75/63	54.9	41.3	62.3	2.24	24.5
				80/67	58.7	42.4	66.2	2.26	26.0
				85/71	62.5	43.5	70.1	2.27	27.6
60	6	2.5	1.1	75/63	49.9	39.1	58.7	2.69	18.5
				80/67	53.2	40.3	62.1	2.72	19.6
				85/71	56.7	41.4	65.7	2.75	20.6
	8	4.3	1.9	75/63	51.2	39.6	59.6	2.57	19.9
				80/67	54.6	40.9	63.1	2.59	21.1
				85/71	58.1	42.0	66.7	2.61	22.3
	12	8.8	3.8	75/63	52.5	40.2	60.5	2.46	21.4
				80/67	56.1	41.3	64.3	2.47	22.7
				85/71	59.8	42.5	68.0	2.48	24.1
70	6	2.5	1.1	75/63	47.5	38.1	57.0	2.93	16.2
				80/67	50.8	39.3	60.4	2.96	17.1
				85/71	53.9	40.5	63.7	2.99	18.0
	8	4.1	1.8	75/63	48.7	38.6	57.9	2.81	17.3
				80/67	52.0	39.9	61.3	2.83	18.4
				85/71	55.4	41.0	64.7	2.85	19.4
	12	8.6	3.7	75/63	50.1	39.0	58.8	2.69	18.6
				80/67	53.5	40.3	62.3	2.70	19.8
				85/71	57.1	41.5	66.0	2.71	21.1
80	6	2.4	1.0	75/63	45.2	37.0	55.5	3.21	14.1
				80/67	48.2	38.3	58.7	3.24	14.9
				85/71	51.3	39.4	62.0	3.27	15.7
	8	4	1.7	75/63	46.2	37.6	56.2	3.08	15.0
				80/67	49.5	38.7	59.5	3.10	15.9
				85/71	52.6	40.1	62.8	3.12	16.8
	12	8.3	3.6	75/63	47.5	38.0	57.0	2.95	16.1
				80/67	50.8	39.2	60.4	2.96	17.1
				85/71	54.1	40.6	63.8	2.97	18.2
85	6	2.3	1.0	75/63	43.8	36.6	54.7	3.37	13.0
				80/67	46.8	37.9	57.8	3.40	13.8
				85/71	49.8	39.1	61.0	3.43	14.5
	8	3.9	1.7	75/63	45.0	36.9	55.4	3.23	13.9
				80/67	48.1	38.2	58.7	3.25	14.8
				85/71	51.3	39.4	62.0	3.27	15.7
	12	8.1	3.5	75/63	46.1	37.5	56.1	3.10	14.9
				80/67	49.4	38.7	59.5	3.11	15.9
				85/71	52.6	40.1	62.8	3.12	16.9
90	6	2.3	1.0	75/63	42.6	36.1	54.0	3.53	12.1
				80/67	45.5	37.4	57.0	3.56	12.8
				85/71	48.5	38.6	60.1	3.60	13.5
	8	3.9	1.7	75/63	43.6	36.5	54.6	3.39	12.8
				80/67	46.8	37.7	57.8	3.42	13.7
				85/71	49.8	39.1	60.9	3.44	14.5
	12	8	3.5	75/63	44.7	37.0	55.2	3.25	13.7
				80/67	48.0	38.2	58.6	3.27	14.7
				85/71	51.3	39.4	62.0	3.28	15.6
100	6	2.2	1.0	75/63	40.0	35.0	52.5	3.90	10.2
				80/67	42.7	36.3	55.4	3.94	10.8
				85/71	45.5	37.6	58.4	3.97	11.4
	8	3.8	1.6	75/63	41.0	35.5	53.1	3.75	10.9
				80/67	43.9	36.8	56.1	3.78	11.6
				85/71	46.8	38.0	59.1	3.80	12.3
	12	7.8	3.4	75/63	42.1	35.8	53.7	3.61	11.7
				80/67	45.1	37.1	56.8	3.62	12.5
				85/71	48.1	38.5	59.9	3.63	13.2
110	6	2.2	1.0	75/63	37.4	34.0	51.3	4.33	8.6
				80/67	39.9	35.3	54.0	4.38	9.1
				85/71	42.7	36.6	57.0	4.42	9.7
	8	3.6	1.6	75/63	38.3	34.4	51.7	4.17	9.2
				80/67	41.1	35.7	54.6	4.20	9.8
				85/71	43.8	37.0	57.5	4.23	10.4
	12	7.6	3.3	75/63	39.4	34.7	52.3	4.02	9.8
				80/67	42.0	36.1	55.0	4.03	10.4
				85/71	45.1	37.4	58.1	4.04	11.1

GP060 HEATING PERFORMANCE - PART LOAD

GP060 Heating Performance – Part Load @ 1500 CFM								
Entering Water, °F	Water flow, GPM	Pressure Drop Ft. Water	Pressure Drop (Psi)	Ent. Air F	Total kBtu/hr.	Ht. Abs. kBtu/hr.	Unit kW	COP
30	7.5	3.7	1.6	60	35.3	26.0	2.85	3.6
				70	35.1	24.5	3.24	3.2
				80	35.0	22.9	3.69	2.8
	10	6.2	2.7	60	36.2	26.9	2.85	3.7
				70	35.9	25.3	3.25	3.2
				80	35.8	23.7	3.69	2.8
	15	12.8	5.6	60	37.2	27.9	2.86	3.8
				70	36.9	26.2	3.25	3.3
				80	36.7	24.5	3.69	2.9
40	7.5	3.5	1.5	60	40.1	30.7	2.87	4.1
				70	39.8	29.0	3.27	3.6
				80	39.6	27.4	3.71	3.1
	10	5.9	2.6	60	41.3	31.9	2.88	4.2
				70	40.9	30.1	3.27	3.7
				80	40.6	28.3	3.72	3.2
	15	12.3	5.3	60	42.8	33.2	2.88	4.4
				70	42.2	31.3	3.27	3.8
				80	41.7	29.4	3.72	3.3
50	7.5	3.4	1.5	60	45.5	36.0	2.89	4.6
				70	45.0	34.2	3.27	4.0
				80	44.6	32.4	3.71	3.5
	10	5.7	2.5	60	47.0	37.4	2.90	4.8
				70	46.4	35.6	3.28	4.2
				80	46.0	33.6	3.71	3.6
	15	11.9	5.2	60	48.8	39.1	2.91	4.9
				70	48.0	37.0	3.28	4.3
				80	47.3	35.0	3.71	3.7
60	7.5	3.3	1.4	60	51.3	41.7	2.92	5.1
				70	50.6	39.7	3.30	4.5
				80	50.1	37.8	3.72	3.9
	10	5.5	2.4	60	53.1	43.5	2.93	5.3
				70	52.3	41.4	3.31	4.6
				80	51.7	39.3	3.73	4.1
	15	11.5	5.0	60	55.3	45.4	2.94	5.5
				70	54.3	43.1	3.32	4.8
				80	53.3	40.9	3.74	4.2
70	7.5	3.2	1.4	60	57.5	47.8	2.96	5.7
				70	56.6	45.6	3.33	5.0
				80	55.9	43.4	3.75	4.4
	10	5.3	2.3	60	59.6	49.9	2.97	5.9
				70	58.6	47.5	3.34	5.1
				80	57.7	45.2	3.77	4.5
	15	11.1	4.8	60	62.1	52.2	2.99	6.1
				70	60.8	49.7	3.36	5.3
				80	59.7	47.1	3.78	4.6
80	7.5	3.1	1.3	60	64.0	54.1	3.00	6.2
				70	62.9	51.7	3.37	5.5
				80	62.0	49.3	3.80	4.8
	10	5.2	2.3	60	66.5	56.5	3.02	6.4
				70	65.2	54.0	3.39	5.6
				80	64.1	51.4	3.81	4.9
	15	10.7	4.6	60	69.4	59.2	3.05	6.7
				70	67.8	56.3	3.41	5.8
				80	66.5	53.4	3.83	5.1

GP060 HEATING PERFORMANCE - FULL LOAD

GP060 Heating Performance – Full Load @ 2000 CFM								
Entering Water, °F	Water flow, GPM	Pressure Drop Ft. Water	Pressure Drop (Psi)	Ent. Air F	Total kBtu/hr.	Ht. Abs. kBtu/hr.	Unit kW	COP
30	7.5	3.7	1.6	60	47.6	34.0	4.13	3.4
				70	47.3	32.1	4.52	3.1
				80	46.5	30.1	4.97	2.7
	10	6.2	2.7	60	49.4	35.4	4.16	3.5
				70	48.8	33.4	4.56	3.1
				80	47.9	31.4	5.00	2.8
	15	12.8	5.6	60	51.3	37.0	4.20	3.6
				70	50.5	34.9	4.60	3.2
				80	49.4	32.8	5.03	2.9
40	7.5	3.5	1.5	60	54.3	39.9	4.27	3.7
				70	53.6	37.9	4.68	3.4
				80	52.8	35.9	5.11	3.0
	10	5.9	2.6	60	56.3	41.8	4.32	3.8
				70	55.5	39.6	4.72	3.4
				80	54.8	37.4	5.16	3.1
	15	12.3	5.3	60	58.7	43.8	4.37	3.9
				70	57.7	41.4	4.77	3.5
				80	56.8	39.1	5.21	3.2
50	7.5	3.4	1.5	60	61.2	46.5	4.43	4.0
				70	60.5	44.3	4.85	3.7
				80	59.8	42.1	5.30	3.3
	10	5.7	2.5	60	63.9	48.9	4.49	4.2
				70	62.9	46.5	4.91	3.8
				80	62.0	44.1	5.36	3.4
	15	11.9	5.2	60	66.9	51.4	4.56	4.3
				70	65.7	48.9	4.98	3.9
				80	64.5	46.4	5.43	3.5
60	7.5	3.3	1.4	60	69.2	53.8	4.61	4.4
				70	68.3	51.5	5.04	4.0
				80	67.5	49.1	5.51	3.6
	10	5.5	2.4	60	72.2	56.6	4.68	4.5
				70	71.0	54.0	5.11	4.1
				80	70.0	51.3	5.58	3.7
	15	11.5	5.0	60	75.8	59.6	4.77	4.7
				70	74.4	56.7	5.20	4.2
				80	73.0	54.0	5.67	3.8
70	7.5	3.2	1.4	60	77.3	61.3	4.81	4.7
				70	76.4	58.9	5.25	4.3
				80	75.4	56.3	5.74	3.8
	10	5.3	2.3	60	81.1	64.7	4.90	4.8
				70	79.8	62.1	5.35	4.4
				80	78.6	59.2	5.84	3.9
	15	11.1	4.8	60	85.3	68.3	5.00	5.0
				70	83.7	65.0	5.45	4.5
				80	82.2	61.8	5.94	4.1
80	7.5	3.1	1.3	60	86.2	69.4	5.03	5.0
				70	84.9	66.6	5.49	4.5
				80	83.6	63.5	5.99	4.1
	10	5.2	2.3	60	90.5	73.4	5.14	5.2
				70	88.9	70.3	5.60	4.6
				80	87.4	67.2	6.11	4.2
	15	10.7	4.6	60	95.3	77.4	5.27	5.3
				70	93.4	73.7	5.73	4.8
				80	91.7	70.0	6.24	4.3

GP060 COOLING PERFORMANCE - PART LOAD

GP060 Cooling Performance - Part Load @ 1500 CFM									
Entering Water °F	Water flow GPM	Pressure Drop Ft. Water	Pressure Drop (Psi)	Cooling					
				Ent. Air db/wb,F	Total kBtu/hr.	Sensible kBtu/hr.	Ht. Rej. kBtu/hr.	Unit kW	EER
50	7.5	3.3	1.4	75/63	49.5	37.7	56.1	2.02	24.5
				80/67	53.0	38.9	59.6	2.01	26.4
				85/71	56.6	40.0	63.2	2.01	28.2
	10	5.5	2.4	75/63	50.2	38.0	56.5	1.92	26.1
				80/67	53.8	39.2	60.1	1.91	28.1
				85/71	57.5	40.4	63.8	1.90	30.2
	15	11.5	5.0	75/63	50.6	37.5	56.9	1.90	26.6
				80/67	54.2	38.7	60.5	1.90	28.6
				85/71	58.3	40.7	64.1	1.76	33.0
60	7.5	3.2	1.4	75/63	47.5	36.8	54.9	2.30	20.7
				80/67	50.9	37.9	58.3	2.29	22.3
				85/71	54.3	39.2	61.7	2.27	23.9
	10	5.3	2.3	75/63	48.1	37.1	55.2	2.21	21.8
				80/67	51.6	38.3	58.7	2.19	23.5
				85/71	55.1	39.5	62.3	2.18	25.3
	15	11.1	4.8	75/63	48.7	37.4	55.6	2.11	23.1
				80/67	52.2	38.6	59.0	2.08	25.1
				85/71	55.7	38.8	62.9	2.15	25.9
70	7.5	3.1	1.3	75/63	45.4	35.8	53.7	2.60	17.4
				80/67	48.5	37.2	56.9	2.58	18.8
				85/71	52.0	38.2	60.4	2.56	20.3
	10	5.2	2.3	75/63	45.9	36.2	54.0	2.51	18.3
				80/67	49.2	37.4	57.3	2.49	19.7
				85/71	52.8	38.5	60.8	2.47	21.4
	15	10.7	4.6	75/63	46.2	36.3	54.2	2.47	18.7
				80/67	49.6	37.5	57.5	2.45	20.2
				85/71	53.1	38.5	61.1	2.43	21.9
80	7.5	3	1.3	75/63	43.1	35.0	52.5	2.93	14.7
				80/67	46.3	36.3	55.6	2.90	15.9
				85/71	49.6	37.4	58.9	2.88	17.2
	10	5	2.2	75/63	43.6	34.7	52.9	2.89	15.1
				80/67	46.8	36.5	55.8	2.80	16.7
				85/71	50.2	37.7	59.2	2.78	18.0
	15	10.4	4.5	75/63	44.1	35.3	53.0	2.79	15.8
				80/67	47.4	36.5	56.3	2.76	17.2
				85/71	50.7	37.9	59.5	2.73	18.6
85	7.5	2.9	1.3	75/63	42.0	34.6	51.9	3.12	13.5
				80/67	45.1	35.7	55.0	3.09	14.6
				85/71	48.3	37.1	58.1	3.05	15.8
	10	4.9	2.1	75/63	42.5	34.8	52.1	3.02	14.1
				80/67	45.6	35.6	55.3	3.04	15.0
				85/71	48.9	36.6	58.6	3.01	16.2
	15	10.2	4.4	75/63	43.0	34.9	52.5	2.97	14.5
				80/67	46.2	36.1	55.6	2.93	15.8
				85/71	49.4	37.5	58.8	2.89	17.1
90	7.5	2.9	1.3	75/63	40.9	34.1	51.4	3.31	12.3
				80/67	44.0	35.3	54.5	3.28	13.4
				85/71	47.0	36.6	57.5	3.24	14.5
	10	4.9	2.1	75/63	41.4	34.3	51.6	3.22	12.8
				80/67	44.4	35.3	54.7	3.22	13.8
				85/71	47.6	36.8	57.7	3.13	15.2
	15	10.1	4.4	75/63	41.9	34.4	51.9	3.15	13.3
				80/67	44.9	35.8	54.9	3.11	14.4
				85/71	48.2	37.0	58.1	3.07	15.7
100	7.5	2.8	1.2	75/63	38.7	33.0	50.7	3.77	10.2
				80/67	41.5	34.5	53.3	3.71	11.2
				85/71	44.5	35.7	56.2	3.67	12.1
	10	4.7	2.0	75/63	39.0	33.3	50.7	3.69	10.6
				80/67	41.9	34.6	53.5	3.64	11.5
				85/71	45.2	35.4	56.7	3.59	12.6
	15	9.8	4.3	75/63	39.6	33.6	51.0	3.56	11.1
				80/67	42.6	34.9	53.8	3.51	12.1
				85/71	45.8	36.0	56.9	3.46	13.2
110	7.5	2.7	1.2	75/63	36.3	32.3	49.9	4.28	8.5
				80/67	39.1	33.3	52.6	4.25	9.2
				85/71	41.9	34.9	55.3	4.18	10.0
	10	4.6	2.0	75/63	36.9	32.4	50.1	4.15	8.9
				80/67	39.7	33.7	52.8	4.11	9.7
				85/71	42.5	35.1	55.5	4.06	10.5
	15	9.5	4.1	75/63	37.4	32.7	50.2	4.03	9.3
				80/67	40.3	33.9	53.0	3.98	10.1
				85/71	43.3	35.2	55.8	3.92	11.0

GP060 COOLING PERFORMANCE - FULL LOAD

GP060 Cooling Performance - Full Load @ 2000 CFM									
Entering Water °F	Water flow GPM	Pressure Drop Ft. Water	Pressure Drop (Psi)	Cooling					
				Ent. Air db/wb,F	Total kBtu/hr.	Sensible kBtu/hr.	Ht. Rej. kBtu/hr.	Unit kW	EER
50	7.5	3.3	1.4	75/63	64.3	47.8	76.6	3.71	17.3
				80/67	68.8	48.9	81.4	3.78	18.2
				85/71	73.3	50.2	86.2	3.85	19.1
	10	5.5	2.4	75/63	65.7	48.0	77.5	3.56	18.5
				80/67	70.2	49.5	82.3	3.61	19.5
				85/71	74.9	50.8	87.2	3.66	20.5
	15	11.5	5.0	75/63	66.8	48.9	78.1	3.40	19.7
				80/67	71.5	50.4	83.0	3.43	20.8
				85/71	76.3	52.2	87.9	3.46	22.1
60	7.5	3.2	1.4	75/63	61.8	46.3	75.2	4.06	15.2
				80/67	66.0	47.8	79.7	4.12	16.0
				85/71	70.3	49.4	84.2	4.18	16.8
	10	5.3	2.3	75/63	63.0	46.8	75.9	3.91	16.1
				80/67	67.4	48.3	80.5	3.95	17.1
				85/71	71.8	50.0	85.2	4.00	18.0
	15	11.1	4.8	75/63	63.8	46.1	76.6	3.86	16.5
				80/67	68.6	49.2	81.2	3.79	18.1
				85/71	73.3	51.0	86.0	3.80	19.3
70	7.5	3.1	1.3	75/63	59.1	45.1	73.6	4.43	13.4
				80/67	63.2	46.6	78.0	4.49	14.1
				85/71	67.4	48.1	82.4	4.55	14.8
	10	5.2	2.3	75/63	60.2	45.5	74.3	4.28	14.1
				80/67	64.3	47.4	78.6	4.31	14.9
				85/71	68.8	48.6	83.3	4.37	15.8
	15	10.7	4.6	75/63	61.0	47.0	74.5	4.10	14.9
				80/67	65.3	49.2	78.8	4.10	15.9
				85/71	70.0	50.4	83.8	4.15	16.9
80	7.5	3	1.3	75/63	56.2	43.9	72.1	4.83	11.6
				80/67	60.2	45.5	76.2	4.89	12.3
				85/71	64.2	47.1	80.5	4.94	13.0
	10	5	2.2	75/63	57.3	44.3	72.6	4.68	12.2
				80/67	61.3	46.1	76.9	4.72	13.0
				85/71	65.7	47.3	81.4	4.77	13.8
	15	10.4	4.5	75/63	58.0	45.9	72.8	4.49	12.9
				80/67	62.2	48.0	77.0	4.51	13.8
				85/71	66.8	48.8	81.8	4.56	14.6
85	7.5	2.9	1.3	75/63	54.8	43.3	71.3	5.05	10.9
				80/67	58.7	44.8	75.4	5.10	11.5
				85/71	62.7	46.2	79.7	5.17	12.1
	10	4.9	2.1	75/63	55.8	43.6	71.9	4.91	11.4
				80/67	59.8	45.4	76.0	4.94	12.1
				85/71	64.0	46.7	80.4	4.99	12.8
	15	10.2	4.4	75/63	56.5	45.2	71.9	4.71	12.0
				80/67	60.6	47.2	76.1	4.73	12.8
				85/71	65.0	46.6	81.1	4.89	13.3
90	7.5	2.9	1.3	75/63	53.3	42.9	70.5	5.27	10.1
				80/67	57.0	44.6	74.5	5.32	10.7
				85/71	61.1	45.6	78.8	5.39	11.3
	10	4.9	2.1	75/63	54.2	43.4	70.9	5.12	10.6
				80/67	58.2	44.8	75.1	5.17	11.3
				85/71	62.2	46.4	79.4	5.21	11.9
	15	10.1	4.4	75/63	54.7	43.7	71.2	5.03	10.9
				80/67	58.9	45.0	75.6	5.07	11.6
				85/71	63.3	47.4	79.8	5.02	12.6
100	7.5	2.8	1.2	75/63	50.4	41.3	69.2	5.78	8.7
				80/67	54.0	43.0	73.0	5.83	9.3
				85/71	57.5	45.2	76.7	5.88	9.8
	10	4.7	2.0	75/63	51.1	41.8	69.5	5.64	9.1
				80/67	54.8	43.9	73.3	5.66	9.7
				85/71	58.7	45.6	77.4	5.70	10.3
	15	9.8	4.3	75/63	51.8	42.5	69.7	5.50	9.4
				80/67	55.6	44.1	73.7	5.54	10.1
				85/71	59.8	45.3	78.1	5.58	10.7
110	7.5	2.7	1.2	75/63	47.2	40.4	67.8	6.33	7.5
				80/67	50.6	42.1	71.5	6.39	7.9
				85/71	54.3	43.6	75.4	6.46	8.4
	10	4.6	2.0	75/63	47.9	40.6	68.2	6.21	7.7
				80/67	51.5	42.5	71.9	6.24	8.3
				85/71	55.2	44.1	75.8	6.28	8.8
	15	9.5	4.1	75/63	48.8	41.1	68.4	6.03	8.1
				80/67	52.6	42.5	72.5	6.07	8.7
				85/71	56.1	44.5	76.1	6.12	9.2

GP072 HEATING PERFORMANCE - PART LOAD

GP072 Heating Performance – Part Load @ 1600 CFM								
Entering Water, °F	Water flow, GPM	Pressure Drop Ft. Water	Pressure Drop (Psi)	Ent. Air F	Total kBtu/hr.	Ht. Abs. kBtu/hr.	Unit kW	COP
30	9	5.3	2.3	60	39.9	28.5	3.51	3.3
				70	39.7	26.7	3.94	3.0
				80	39.7	24.9	4.41	2.6
	12	8.9	3.9	60	40.9	29.4	3.51	3.4
				70	40.5	27.6	3.94	3.0
				80	40.6	25.6	4.42	2.7
	18	18.4	8.0	60	42.0	30.4	3.52	3.5
				70	41.5	28.4	3.95	3.1
				80	41.3	26.5	4.43	2.7
40	9	5.1	2.2	60	45.5	33.7	3.55	3.8
				70	45.2	31.8	3.99	3.3
				80	44.8	29.9	4.46	2.9
	12	8.5	3.7	60	46.7	35.0	3.57	3.8
				70	46.1	33.0	4.00	3.4
				80	45.6	31.0	4.47	3.0
	18	17.7	7.7	60	48.1	36.3	3.58	3.9
				70	47.4	34.1	4.01	3.5
				80	46.8	31.9	4.48	3.1
50	9	4.9	2.1	60	51.6	39.6	3.61	4.2
				70	51.0	37.5	4.04	3.7
				80	50.4	35.4	4.52	3.3
	12	8.3	3.6	60	53.1	41.1	3.62	4.3
				70	52.4	38.9	4.04	3.8
				80	51.8	36.6	4.53	3.4
	18	17.1	7.4	60	54.9	42.8	3.63	4.4
				70	53.9	40.4	4.05	3.9
				80	53.2	38.0	4.53	3.4
60	9	4.7	2.0	60	58.2	46.1	3.66	4.7
				70	57.3	43.8	4.07	4.1
				80	56.7	41.4	4.54	3.7
	12	8	3.5	60	60.0	47.9	3.67	4.8
				70	59.0	45.4	4.08	4.2
				80	58.2	43.0	4.54	3.8
	18	16.5	7.2	60	62.1	49.9	3.69	4.9
				70	60.9	47.2	4.09	4.4
				80	59.8	44.6	4.55	3.8
70	9	4.6	2.0	60	65.1	52.9	3.71	5.1
				70	64.0	50.3	4.12	4.6
				80	63.1	47.8	4.58	4.0
	12	7.7	3.3	60	67.3	55.0	3.73	5.3
				70	66.0	52.3	4.14	4.7
				80	64.9	49.6	4.59	4.1
	18	16	6.9	60	69.8	57.4	3.75	5.5
				70	68.2	54.4	4.15	4.8
				80	66.8	51.4	4.61	4.2
80	9	4.4	1.9	60	72.4	59.9	3.77	5.6
				70	70.7	57.3	4.18	5.0
				80	69.8	54.3	4.63	4.4
	12	7.4	3.2	60	74.9	62.4	3.79	5.8
				70	73.3	59.4	4.20	5.1
				80	71.9	56.4	4.65	4.5
	18	15.4	6.7	60	77.8	65.1	3.82	6.0
				70	75.9	61.9	4.22	5.3
				80	74.2	58.6	4.67	4.7

GP072 HEATING PERFORMANCE - FULL LOAD

GP072 Heating Performance – Full Load @ 2200 CFM								
Entering Water, °F	Water flow, GPM	Pressure Drop Ft. Water	Pressure Drop (Psi)	Ent. Air F	Total kBtu/hr.	Ht. Abs. kBtu/hr.	Unit kW	COP
30	9	5.3	2.3	60	52.5	37.5	4.52	3.4
				70	51.8	35.4	4.91	3.1
				80	51.2	33.3	5.33	2.8
	12	8.9	3.9	60	54.0	38.8	4.56	3.5
				70	53.2	36.7	4.95	3.2
				80	52.5	34.4	5.36	2.9
	18	18.4	8.0	60	55.8	40.1	4.60	3.6
				70	54.7	37.9	4.98	3.2
				80	53.8	35.7	5.40	2.9
40	9	5.1	2.2	60	59.2	43.7	4.68	3.7
				70	58.6	41.4	5.07	3.4
				80	57.7	39.3	5.48	3.1
	12	8.5	3.7	60	61.2	45.4	4.72	3.8
				70	60.1	43.1	5.11	3.4
				80	59.3	40.8	5.52	3.1
	18	17.7	7.7	60	63.5	47.2	4.77	3.9
				70	62.3	44.6	5.16	3.5
				80	61.1	42.3	5.57	3.2
50	9	4.9	2.1	60	66.9	50.9	4.84	4.0
				70	65.8	48.5	5.24	3.7
				80	64.8	45.8	5.66	3.4
	12	8.3	3.6	60	69.3	53.3	4.90	4.1
				70	68.2	50.2	5.29	3.8
				80	67.1	47.6	5.72	3.4
	18	17.1	7.4	60	71.9	55.2	4.95	4.3
				70	70.5	52.7	5.35	3.9
				80	69.2	49.8	5.77	3.5
60	9	4.7	2.0	60	75.2	58.2	5.02	4.4
				70	74.0	55.4	5.42	4.0
				80	72.9	52.6	5.86	3.6
	12	8	3.5	60	78.0	61.4	5.08	4.5
				70	76.5	58.6	5.49	4.1
				80	75.3	55.0	5.92	3.7
	18	16.5	7.2	60	81.2	63.7	5.15	4.6
				70	79.4	60.6	5.56	4.2
				80	77.8	57.8	6.00	3.8
70	9	4.6	2.0	60	83.8	66.6	5.21	4.7
				70	82.3	63.7	5.63	4.3
				80	80.8	60.5	6.07	3.9
	12	7.7	3.3	60	86.7	69.3	5.28	4.8
				70	84.9	66.2	5.70	4.4
				80	83.2	62.9	6.14	4.0
	18	16	6.9	60	91.0	72.8	5.37	5.0
				70	89.0	69.2	5.79	4.5
				80	87.3	65.9	6.24	4.1
80	9	4.4	1.9	60	92.8	74.9	5.41	5.0
				70	91.1	71.6	5.84	4.6
				80	89.4	68.3	6.30	4.2
	12	7.4	3.2	60	97.0	78.9	5.51	5.2
				70	94.9	75.4	5.94	4.7
				80	93.0	71.9	6.40	4.3
	18	15.4	6.7	60	101.3	82.3	5.62	5.3
				70	98.9	78.2	6.04	4.8
				80	97.0	74.5	6.51	4.4

GP072 COOLING PERFORMANCE - PART LOAD

GP072 Cooling Performance - Part Load @ 1600 CFM									
Entering Water °F	Water flow GPM	Pressure Drop Ft. Water	Pressure Drop (Psi)	Cooling					
				Ent. Air db/wb,F	Total kBtu/hr.	Sensible kBtu/hr.	Ht. Rej. kBtu/hr.	Unit kW	EER
50	9	4.7	2.0	75/63	57.6	42.2	66.0	2.53	22.8
				80/67	61.7	43.5	70.1	2.53	24.4
				85/71	66.0	44.6	74.4	2.53	26.1
	12	8	3.5	75/63	58.5	42.6	66.5	2.42	24.2
				80/67	62.7	43.9	70.8	2.42	25.9
				85/71	67.1	45.0	75.2	2.41	27.8
	18	16.5	7.2	75/63	59.3	43.0	67.0	2.31	25.7
				80/67	63.7	44.3	71.4	2.30	27.7
				85/71	68.2	45.6	75.9	2.29	29.8
60	9	4.6	2.0	75/63	55.1	41.2	64.4	2.83	19.5
				80/67	59.1	42.5	68.4	2.82	20.9
				85/71	63.3	43.6	72.6	2.82	22.5
	12	7.7	3.3	75/63	56.0	41.6	64.9	2.73	20.5
				80/67	60.1	42.9	69.0	2.71	22.2
				85/71	64.3	44.1	73.2	2.70	23.8
	18	16	6.9	75/63	56.8	42.0	65.4	2.62	21.7
				80/67	61.0	43.3	69.6	2.60	23.4
				85/71	65.4	44.5	74.0	2.59	25.3
70	9	4.4	1.9	75/63	52.7	40.0	62.9	3.15	16.7
				80/67	56.5	41.3	66.8	3.14	18.0
				85/71	60.4	42.7	70.7	3.12	19.4
	12	7.4	3.2	75/63	53.4	40.4	63.3	3.05	17.5
				80/67	57.4	41.7	67.3	3.03	19.0
				85/71	61.5	43.0	71.4	3.01	20.5
	18	15.4	6.7	75/63	54.2	40.8	63.8	2.95	18.4
				80/67	58.3	42.1	67.9	2.92	20.0
				85/71	62.6	43.3	72.1	2.89	21.6
80	9	4.3	1.9	75/63	50.0	39.0	61.4	3.51	14.3
				80/67	53.7	40.3	65.0	3.48	15.4
				85/71	57.5	41.6	68.8	3.46	16.6
	12	7.2	3.1	75/63	50.9	39.2	61.9	3.40	15.0
				80/67	54.6	40.7	65.5	3.37	16.2
				85/71	58.5	42.0	69.4	3.34	17.5
	18	15	6.5	75/63	51.6	39.5	62.3	3.30	15.6
				80/67	55.4	41.0	66.1	3.26	17.0
				85/71	59.6	42.2	70.1	3.23	18.5
85	9	4.2	1.8	75/63	48.7	38.4	60.6	3.70	13.2
				80/67	52.4	39.7	64.3	3.67	14.3
				85/71	56.0	41.1	67.9	3.64	15.4
	12	7.1	3.1	75/63	49.4	38.7	61.0	3.59	13.8
				80/67	53.2	40.0	64.8	3.55	15.0
				85/71	57.0	41.4	68.5	3.52	16.2
	18	14.7	6.4	75/63	50.2	39.0	61.4	3.48	14.4
				80/67	54.0	40.4	65.2	3.44	15.7
				85/71	57.9	41.8	69.1	3.40	17.0
90	9	4.2	1.8	75/63	47.3	37.9	59.9	3.90	12.1
				80/67	50.9	39.2	63.4	3.87	13.2
				85/71	54.6	40.4	67.1	3.84	14.2
	12	7	3.0	75/63	48.1	38.2	60.3	3.79	12.7
				80/67	51.8	39.4	63.9	3.75	13.8
				85/71	55.6	40.8	67.6	3.72	15.0
	18	14.5	6.3	75/63	48.8	38.4	60.6	3.69	13.2
				80/67	52.6	39.7	64.4	3.64	14.4
				85/71	56.4	41.2	68.1	3.60	15.7
100	9	4	1.7	75/63	44.6	36.7	58.6	4.36	10.2
				80/67	48.1	38.0	62.0	4.32	11.1
				85/71	51.6	39.3	65.4	4.28	12.1
	12	6.8	3.0	75/63	45.3	37.0	58.9	4.25	10.7
				80/67	48.8	38.3	62.4	4.20	11.6
				85/71	52.3	39.8	65.8	4.15	12.6
	18	14.1	6.1	75/63	45.9	37.3	59.2	4.14	11.1
				80/67	49.6	38.6	62.7	4.08	12.2
				85/71	53.2	40.1	66.2	4.02	13.2
110	9	3.9	1.7	75/63	42.0	35.7	57.6	4.88	8.6
				80/67	45.1	37.0	60.7	4.84	9.3
				85/71	48.4	38.4	63.9	4.79	10.1
	12	6.6	2.9	75/63	42.6	35.8	57.9	4.77	8.9
				80/67	45.8	37.3	60.9	4.71	9.7
				85/71	49.2	38.7	64.2	4.65	10.6
	18	13.7	5.9	75/63	43.1	36.0	58.1	4.66	9.2
				80/67	46.5	37.4	61.3	4.60	10.1
				85/71	49.9	38.9	64.5	4.53	11.0

GP072 COOLING PERFORMANCE - FULL LOAD

GP072 Cooling Performance – Full Load @ 2200 CFM									
Entering Water °F	Water flow GPM	Pressure Drop Ft. Water	Pressure Drop (Psi)	Cooling					
				Ent. Air db/wb,F	Total kBtu/hr.	Sensible kBtu/hr.	Ht. Rej. kBtu/hr.	Unit kW	EER
50	9	4.7	2.0	75/63	76.3	56.3	90.2	4.21	18.1
				80/67	81.4	57.9	95.5	4.27	19.1
				85/71	86.6	59.3	101.0	4.34	20.0
	12	8	3.5	75/63	77.6	57.0	91.1	4.05	19.2
				80/67	82.9	58.6	96.5	4.10	20.2
				85/71	88.3	60.0	102.2	4.16	21.2
	18	16.5	7.2	75/63	79.1	57.6	91.9	3.87	20.4
				80/67	84.5	59.3	97.5	3.92	21.6
				85/71	90.1	60.7	103.3	3.97	22.7
60	9	4.6	2.0	75/63	73.3	55.1	88.2	4.54	16.2
				80/67	78.2	56.6	93.4	4.60	17.0
				85/71	83.3	58.1	98.8	4.67	17.8
	12	7.7	3.3	75/63	74.6	55.7	89.1	4.38	17.0
				80/67	79.7	57.3	94.4	4.43	18.0
				85/71	85.0	58.8	99.9	4.49	18.9
	18	16	6.9	75/63	76.0	56.3	89.9	4.22	18.0
				80/67	81.3	58.0	95.4	4.26	19.1
				85/71	86.7	59.5	101.1	4.31	20.1
70	9	4.4	1.9	75/63	70.2	53.7	86.3	4.90	14.3
				80/67	75.0	55.2	91.4	4.96	15.1
				85/71	79.9	56.8	96.5	5.02	15.9
	12	7.4	3.2	75/63	71.5	54.3	87.1	4.74	15.1
				80/67	76.5	55.8	92.3	4.79	16.0
				85/71	81.6	57.4	97.6	4.85	16.8
	18	15.4	6.7	75/63	72.8	54.6	88.0	4.62	15.8
				80/67	77.9	56.4	93.2	4.64	16.8
				85/71	83.1	58.1	98.7	4.68	17.8
80	9	4.3	1.9	75/63	67.1	52.2	84.4	5.29	12.7
				80/67	71.7	53.9	89.2	5.35	13.4
				85/71	76.4	55.5	94.2	5.41	14.1
	12	7.2	3.1	75/63	68.3	52.8	85.1	5.13	13.3
				80/67	73.0	54.6	90.0	5.18	14.1
				85/71	77.9	56.2	95.1	5.23	14.9
	18	15	6.5	75/63	69.4	53.3	85.7	4.99	13.9
				80/67	74.3	55.1	90.9	5.03	14.8
				85/71	79.5	56.6	96.3	5.07	15.7
85	9	4.2	1.8	75/63	65.4	51.7	83.3	5.50	11.9
				80/67	70.0	53.2	88.2	5.56	12.6
				85/71	74.5	55.0	93.0	5.62	13.3
	12	7.1	3.1	75/63	66.7	52.0	84.2	5.35	12.5
				80/67	71.3	53.8	89.0	5.39	13.2
				85/71	76.2	55.4	94.1	5.44	14.0
	18	14.7	6.4	75/63	67.6	52.6	84.7	5.20	13.0
				80/67	72.6	54.4	89.8	5.24	13.9
				85/71	77.5	56.1	94.9	5.27	14.7
90	9	4.2	1.8	75/63	63.8	50.9	82.5	5.72	11.2
				80/67	68.1	52.7	87.0	5.78	11.8
				85/71	72.8	54.2	92.0	5.85	12.5
	12	7	3.0	75/63	64.8	51.5	83.0	5.56	11.7
				80/67	69.4	53.2	87.8	5.61	12.4
				85/71	74.1	54.9	92.7	5.66	13.1
	18	14.5	6.3	75/63	65.8	50.5	83.9	5.51	11.9
				80/67	70.7	53.6	88.6	5.46	12.9
				85/71	75.7	55.0	93.8	5.51	13.7
100	9	4	1.7	75/63	60.4	49.4	80.6	6.20	9.7
				80/67	64.6	51.2	85.1	6.26	10.3
				85/71	69.0	52.8	89.7	6.33	10.9
	12	6.8	3.0	75/63	61.4	49.8	81.2	6.05	10.1
				80/67	65.7	51.8	85.6	6.09	10.8
				85/71	70.2	53.5	90.3	6.13	11.4
	18	14.1	6.1	75/63	62.2	49.7	81.7	5.97	10.4
				80/67	66.8	52.2	86.1	5.90	11.3
				85/71	71.5	54.0	91.1	5.98	12.0
110	9	3.9	1.7	75/63	56.9	48.0	78.8	6.75	8.4
				80/67	60.9	49.8	83.1	6.81	8.9
				85/71	65.0	51.5	87.5	6.88	9.4
	12	6.6	2.9	75/63	57.8	48.5	79.3	6.60	8.8
				80/67	62.0	50.2	83.7	6.64	9.3
				85/71	66.2	52.1	88.1	6.68	9.9
	18	13.7	5.9	75/63	58.4	48.8	79.5	6.50	9.0
				80/67	62.8	50.7	84.0	6.47	9.7
				85/71	67.4	51.6	89.0	6.58	10.2

ANTI-FREEZE CORRECTION TABLE

Antifreeze Type	Antifreeze % volume	Cooling			Heating		WPD Correction Factor EWT 30°F
		EWT 90 °F			EWT 30 °F		
		Total Cap.	Sens. Cap	Power	Htg. Cap	Power	
Water	0	1.000	1.000	1.000	1.000	1.000	1.000
Propylene Glycol	5	0.997	0.997	1.004	0.989	0.997	1.060
	10	0.994	0.994	1.006	0.986	0.995	1.125
	15	0.990	0.990	1.009	0.978	0.988	1.190
	25	0.983	0.983	1.016	0.960	0.979	1.300
Methanol	5	0.997	0.997	1.003	0.990	0.997	1.060
	10	0.996	0.996	1.005	0.979	0.993	1.100
	15	0.994	0.994	1.008	0.970	0.990	1.140
Ethanol	5	0.998	0.998	1.002	0.981	0.994	1.160
	10	0.996	0.996	1.004	0.960	0.988	1.230
	15	0.992	0.992	1.006	0.944	0.983	1.280
	25	0.986	0.986	1.009	0.917	0.974	1.400

