

FPMA
Sizes 018 thru 036
FPMB
Sizes 018 thru 030
Base Series Horizontal Fan Coil

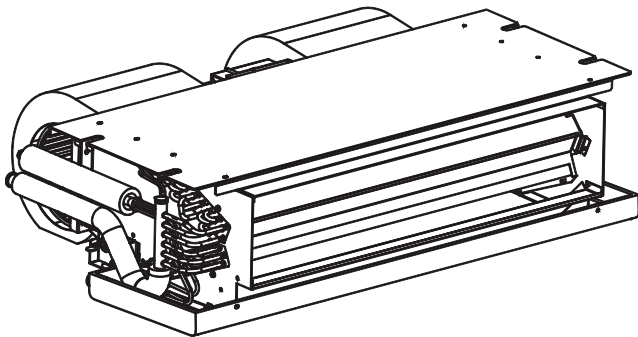

Product Data



A13303

Fig. 1 - FPM(A,B)NU Uncased Horizontal Fan Coil
(FPMANU model shown)

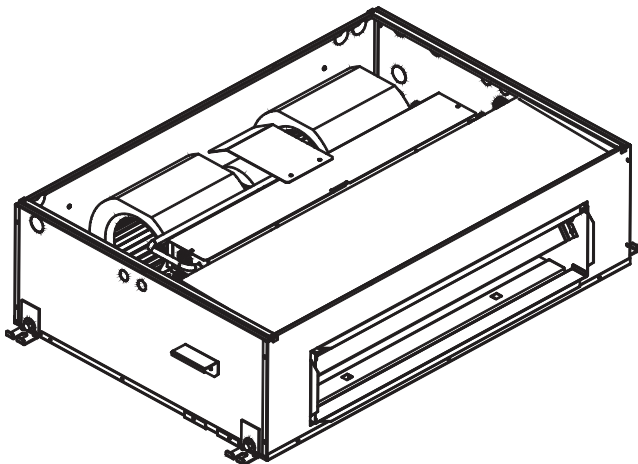

A13304

Fig. 2 - FPM(A,B)NC Cased Horizontal Fan Coil
(Unit pictured upside down)

The FPM(A,B) Series Fan Coil unit is primarily designed for multi-family applications as a horizontal only indoor fan coil for split-system heat pumps for use with Puron® refrigerant. The FPM(A,B) series fan coil is available in cased or uncased versions from the factory. Accessory field-installed electric heat kits are available in 3, 5, 6, 7.5 or 10 kW sizes. The electric heat, however, cannot be run simultaneously with refrigerant heat. The factory electric heat kits for the FPM(A,B) come with a control to prevent both electric heat and heat-pump heat from operating simultaneously.

The FPMA comes with a piston refrigerant metering device. The FPMB comes with a factory installed Puron TXV. These fan coils come configured for Puron refrigerant. However, they can be used for R-22 applications with the addition of an R-22 TXV kit.

The uncased version can be installed in a furred-in ceiling or in a field fabricated casing or duct. The cased version can be installed in a furred-in ceiling or with ducted return. Return air must be pass through a filter in all applications. Local codes may limit free-air-return type installations to single-level applications.

A louvered return air panel, which is sized for unit access and accepts either 1-in. or 2-in. air filters, is available as an accessory. A solid access panel also is available.

Please note that when using the cased model, FPM(A,B)NC, in horizontal return applications, a bottom cover will need to be field fabricated.

Designated mounting locations are provided on the equipment. The factory cased version is fully insulated to meet applications in conditioned space. It also should be noted that the unique cabinet design of the cased coil meets the requirement of 2% cabinet leakage rate when tested at 1.0-in. of static pressure. This unit is not approved for installation in unconditioned spaces.

PSC blower motors have been selected to provide the proper air handling for both heating and cooling.

Refrigerant line connections are made on the side of the unit while the high and low voltage connections are made from either the right or left side of the fan coil. Sweat-type refrigerant connections on both liquid and vapor lines make for swift, low-cost installation. On cased units, the refrigerant lines can be run out the back or side of the unit while electrical connections can be run out either side or back of the casing.

Primary and secondary drain connections exit from the back or side of the cabinet.

STANDARD FEATURES

Environmentally-Sound Refrigerant Technology

- Designed for Puron® refrigerant, the chlorine-free non-ozone depleting refrigerant

Quality Assisting, Ease of Installation

- Cased version meets requirements of a 2% cabinet leakage rate when tested at 1.0-in. w.c. of static pressure.
- Provisions made for suspending from ceiling joints
- Multiple electrical, refrigerant lineset and drain line entry for application flexibility
- Sweat connections for leak free service
- Cabinet construction features innovations designed to prevent cabinet sweating

Heat Transfer Technology

- Grooved copper tubing
- A-coil design for maximum surface area

Controls and Electrical Features

- 40VA 208/230v transformer

MODEL NUMBER NOMENCLATURE

1 2 3 4 5 6 7 8 9 10 11 12
F P M A N U 0 1 8 0 0 0

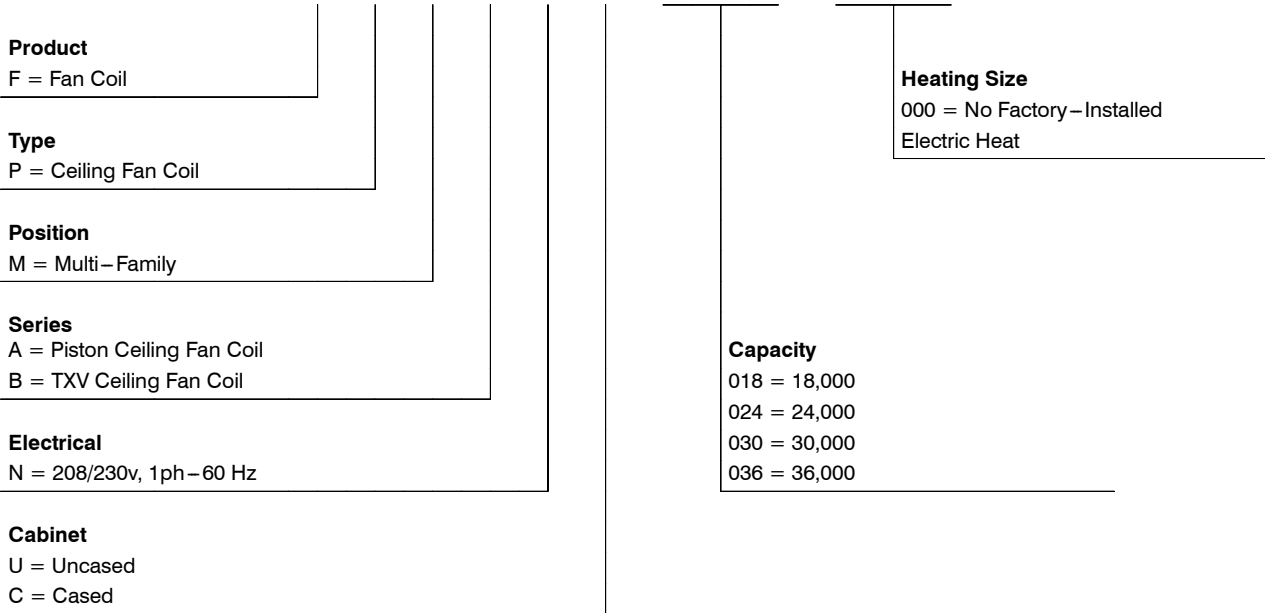

Use of the AHRI Certified TM Mark indicates a manufacturer's participation in the program. For verification of certification for individual products, go to www.ahridirectory.org.



DIMENSIONS

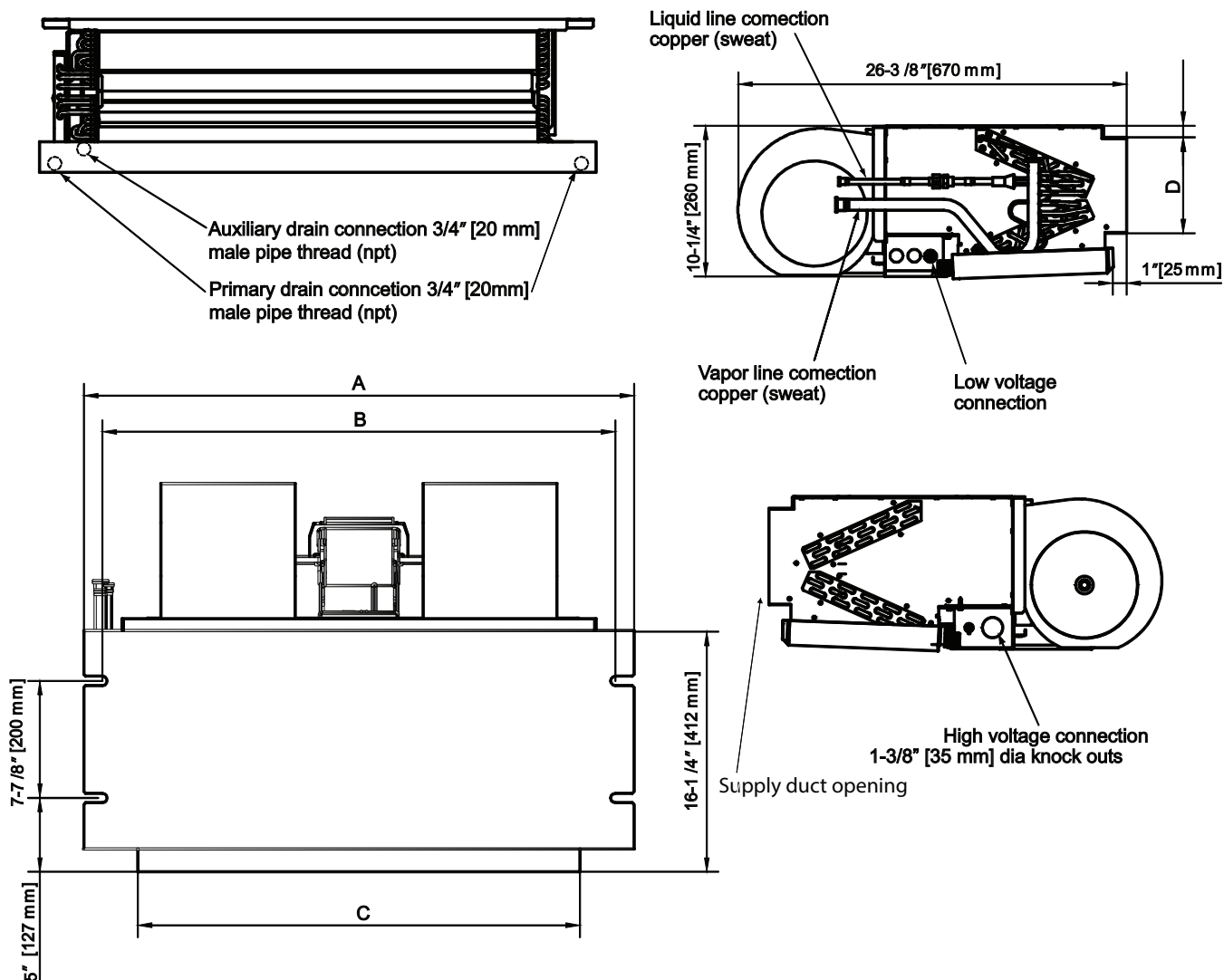

Fig. 3 - FPM(A,B)NU Uncased Horizontal Fan Coil Dimensional Drawing
(FPMANU model shown)

A150454

FPM(A,B)NU DIMENSIONAL DATA

Model Size	Dimensions- inches [mm]				Unit Operating Weight lbs (kg)
	"A"	"B"	"C"	"D"	
18	37-1/4 [946]	34-11/16 [881]	30 [762]	6-1/2 [165]	75 (34)
24	37-1/4 [946]	34-11/16 [881]	30 [762]	6-1/2 [165]	75 (34)
30	49-1/4 [1251]	46-11/16 [1186]	42 [1067]	6-1/2 [165]	93 (42)
36	49-1/4 [1251]	46-11/16 [1186]	42 [1067]	6-1/2 [165]	93 (42)

DIMENSIONS (CONT.)

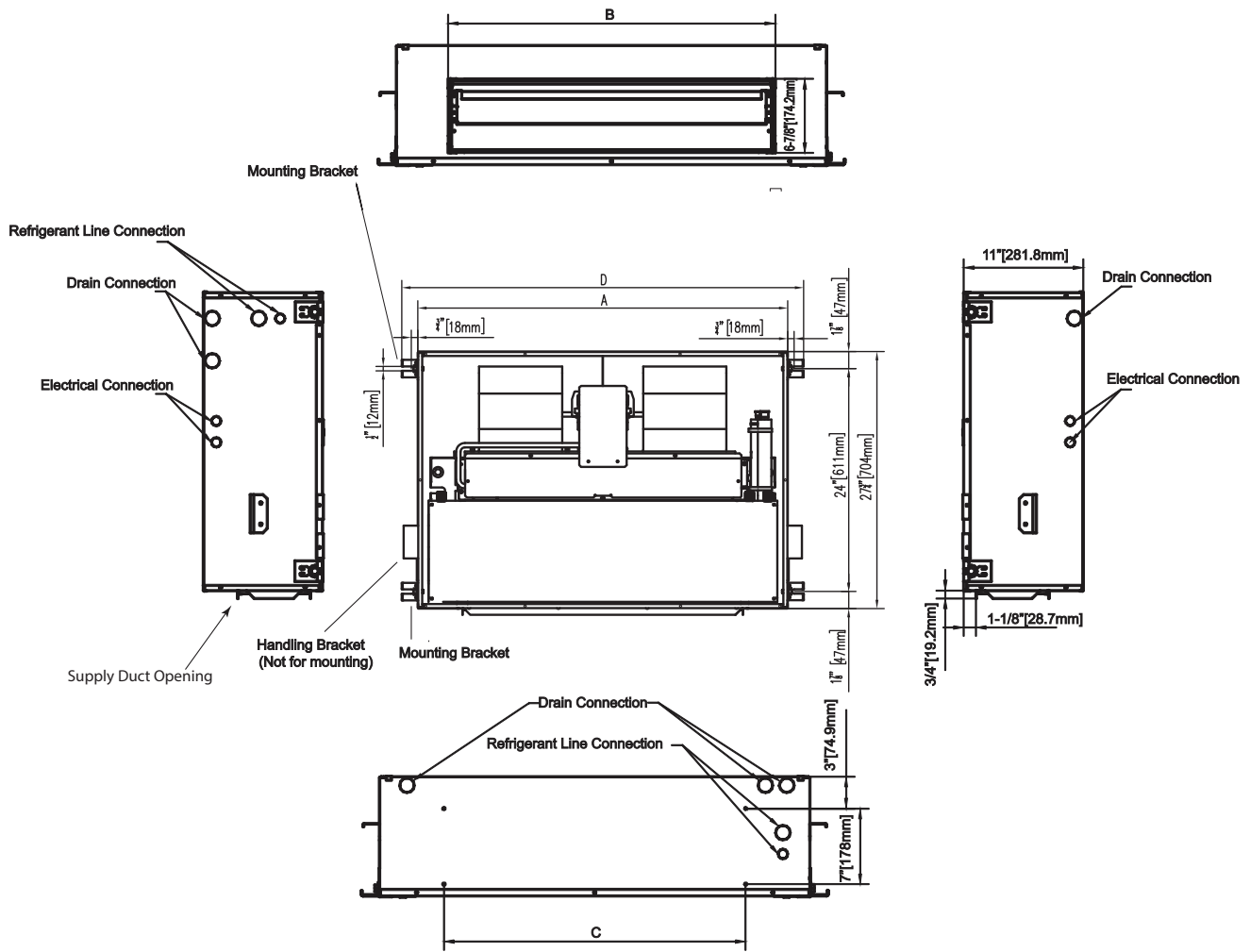

**Fig. 4 - FPM(A,B)NC Cased Horizontal Fan Coil Dimensional Drawing
(FPMANC model shown)**

A150455A

FPM(A,B)NC DIMENSIONAL DATA

Model Size	Dimensions- inches [mm]				Unit Operating Weight lbs (kg)
	"A"	"B"	"C"	"D"	
18	39-3/4 [1010]	30-3/8 [771]	28 [711]	43-3/8 [1101]	109 (49)
24	39-3/4 [1010]	30-3/8 [771]	28 [711]	43-3/8 [1101]	109 (49)
30	51-3/4 [1315]	42-3/8 [1076]	40 [1016]	55-3/8 [1406]	135 (61)
36	51-3/4 [1315]	42-3/8 [1076]	40 [1016]	55-3/8 [1406]	135 (61)

SPECIFICATIONS

FPMAN(C,U)	Unit Size			
	18	24	30	36
Nominal Cooling Capacity (BTUH)	18,000	24,000	30,000	36,000
COIL				
Puron (R-410A) - Refrigerant Metering Device (Piston)*	50 (1.27mm)	56 (1.42mm)	67 (1.7mm)	70 (1.78mm)
Coil Configuration	A-Coil			
BLOWER & MOTOR				
Air Discharge	Horizontal			
Blower Type	Dual Blower Direct Drive			
CFM (Nominal)	600	800	1000	1200
Motor Type	PSC	PSC	PSC	PSC
Motor HP	1/8	1/8	1/3	1/3
Rated RPM	1075	1075	1600	1600
Motor Speeds	3	3	3	3
FILTER				
Field Installed – in. (mm)	Qty. 2– 16x20x1 (406x508x25)	Qty. 2– 16x20x1 (406x508x25)	Qty. 2– 20x20x1 (508x508x25)	Qty. 2– 20x20x1 (508x508x25)
CONNECTIONS				
Suction Sweat – in. (mm)	3/4 In. (19 mm)			
Liquid Sweat – in. (mm)	3/8 In. (9.5 mm)			
Condensate (MPT) – in. (mm)	3/4 In. (19 mm)			
ELECTRICAL DATA				
Voltage	208/230	208/230	208/230	208/230
Hertz	60	60	60	60
Minimum Circuit Ampacity	1.32	1.32	2.2	2.2
Maximum Circuit Protector	15 (A)	15 (A)	15 (A)	15 (A)

* The piston included with the fan coil is unique to this product and **CANNOT** be replaced with the piston shipped with outdoor unit. Refer to the AHRI ratings to check if your combination can use the piston shipped with the fan coil if an accessory TXV is required.

FPMBN(C,U)	Unit Size		
	18	24	30
Nominal Cooling Capacity (BTUH)	18,000	24,000	30,000
COIL			
Puron (R-410A) - Refrigerant Metering Device	TXV		
Coil Configuration	A-Coil		
BLOWER & MOTOR			
Air Discharge	Horizontal		
Blower Type	Dual Blower Direct Drive		
CFM (Nominal)	600	800	1000
Motor Type	PSC	PSC	PSC
Motor HP	1/8	1/8	1/3
Rated RPM	1075	1075	1600
Motor Speeds	3	3	3
FILTER			
Field Installed – in. (mm)	Qty. 2– 16x20x1 (406x508x25)	Qty. 2– 16x20x1 (406x508x25)	Qty. 2– 20x20x1 (508x508x25)
CONNECTIONS			
Suction Sweat – in. (mm)	3/4 In. (19 mm)		
Liquid Sweat – in. (mm)	3/8 In. (9.5 mm)		
Condensate (MPT) – in. (mm)	3/4 In. (19 mm)		
ELECTRICAL DATA			
Voltage	208/230	208/230	208/230
Hertz	60	60	60
Minimum Circuit Ampacity	1.32	1.32	2.2
Maximum Circuit Protector	15 (A)	15 (A)	15 (A)

PERFORMANCE DATA

AIRFLOW PERFORMANCE (Standard CFM)

Use for Selecting Electric Heat Speed

Model	Motor Speed	CFM Dry Coil without Filter or Electric Heat						
		External Static Pressure-Inches W.C. [kPa]						
		0 [0]	0.05 [.01]	0.1 [.02]	0.15 [.04]	0.2 [.05]	0.25 [.06]	0.3 [.07]
18	Low	762	724	686	642	598	513	448
	Medium	1033	981	932	876	819	735	667
	High	1062	1007	953	888	825	764	722
24	Low	762	724	686	642	598	513	448
	Medium	1033	981	932	876	819	735	667
	High	1062	1007	953	888	825	764	722
30	Low	1200	1152	1116	1073	1039	989	924
	Medium	1331	1285	1242	1205	1165	1121	1050
	High	1449	1402	1361	1322	1284	1235	1198
36	Low	1200	1152	1116	1073	1039	989	924
	Medium	1331	1285	1242	1205	1165	1121	1050
	High	1449	1402	1361	1322	1284	1235	1198

AIRFLOW PERFORMANCE (Standard CFM)

Use for Selecting Cooling and Heat Pump Speed

Model	Motor Speed	CFM Wet Coil without Filter or Electric Heat						
		External Static Pressure-Inches W.C. [kPa]						
		0 [0]	0.05 [.01]	0.1 [.02]	0.15 [.04]	0.2 [.05]	0.25 [.06]	0.3 [.07]
18	Low	747	671	623	575	528	469	397
	Medium	996	912	833	765	683	609	518
	High	1051	974	888	816	742	665	576
24	Low	747	671	623	575	528	469	397
	Medium	996	912	833	765	683	609	518
	High	1051	974	888	816	742	665	576
30	Low	1211	1150	1069	1017	958	906	849
	Medium	1313	1261	1216	1151	1105	1051	984
	High	1428	1377	1315	1244	1198	1148	1089
36	Low	1211	1150	1069	1017	958	906	849
	Medium	1313	1261	1216	1151	1105	1051	984
	High	1428	1377	1315	1244	1198	1148	1089

■ – Shaded boxes represent airflow outside the required 300-450 cfm/ton.

NOTES:

1. Airflow data is without filter or electric heat accessory. Heater adds 0.05" static.
2. Use dry coil data for determining electric heater airflow.
3. Use wet coil data for determining cooling airflow.

REQUIRED CFM RANGE

Size	CFM	
	Min	Max
18	450	675
24	600	900
30	750	1125
36	900	1350

PERFORMANCE DATA (CONT.)

GROSS COOLING CAPACITIES (mbh)

Unit Size	INDOOR COIL AIR		SATURATED TEMPERATURE LEAVING EVAPORATOR ° F (° C)														
			35 (2)			40 (4)			45 (7)			50 (10)			55 (13)		
	CFM	EWB	TC	SHC	BF	TC	SHC	BF	TC	SHC	BF	TC	SHC	BF	TC	SHC	BF
18	525	72 (22)	40	21	0.00	36	19	0.00	32	17	0.01	27	15	0.03	22	12	0.04
		67 (19)	33	22	0.04	29	19	0.04	24	17	0.04	19	15	0.04	14	12	0.05
		62 (17)	26	22	0.05	22	20	0.05	18	17	0.05	14	14	0.08	12	12	0.23
	600	72 (22)	45	24	0.00	40	21	0.00	35	19	0.03	30	16	0.04	24	14	0.05
		67 (19)	36	24	0.05	32	22	0.05	27	19	0.05	22	16	0.06	15	14	0.06
		62 (17)	29	24	0.06	25	22	0.06	20	19	0.06	16	16	0.09	13	13	0.25
	675	72 (22)	49	26	0.00	44	23	0.00	38	20	0.04	32	18	0.05	26	15	0.06
		67 (19)	40	26	0.06	35	24	0.06	29	21	0.07	23	18	0.07	17	15	0.07
		62 (17)	32	27	0.07	27	24	0.07	22	21	0.07	17	17	0.10	14	14	0.26
24	700	72 (22)	54	27	0.00	48	25	0.00	42	22	0.04	36	19	0.06	29	16	0.06
		67 (19)	44	28	0.06	39	25	0.07	33	22	0.07	26	19	0.07	18	16	0.07
		62 (17)	35	29	0.07	30	26	0.07	24	23	0.07	19	19	0.11	16	16	0.26
	800	72 (22)	59	30	0.00	53	27	0.01	47	24	0.06	39	21	0.07	31	18	0.08
		67 (19)	48	31	0.08	42	28	0.08	36	25	0.08	28	21	0.09	20	18	0.09
		62 (17)	39	32	0.09	33	28	0.09	26	25	0.09	22	22	0.13	18	18	0.28
	900	72 (22)	64	33	0.00	57	30	0.03	50	26	0.07	43	23	0.09	34	19	0.09
		67 (19)	52	34	0.09	46	30	0.10	39	27	0.10	31	23	0.10	22	20	0.10
		62 (17)	42	35	0.10	35	31	0.10	29	28	0.10	24	24	0.15	20	20	0.29
30	875	72 (22)	64	31	0.04	59	29	0.05	53	26	0.05	45	23	0.06	37	20	0.06
		67 (19)	53	33	0.06	48	31	0.06	41	28	0.06	34	25	0.06	25	21	0.06
		62 (17)	43	35	0.06	38	32	0.06	32	30	0.06	27	27	0.14	23	23	0.28
	1000	72 (22)	69	34	0.05	63	31	0.06	57	28	0.07	49	25	0.07	40	22	0.07
		67 (19)	57	36	0.07	51	33	0.07	44	30	0.07	36	27	0.07	27	24	0.07
		62 (17)	47	38	0.07	41	36	0.07	34	33	0.08	30	30	0.17	25	25	0.30
	1100	72 (22)	72	35	0.07	66	33	0.07	59	30	0.08	51	27	0.08	42	23	0.08
		67 (19)	60	38	0.08	54	35	0.08	46	32	0.08	38	29	0.08	29	25	0.08
		62 (17)	49	41	0.08	43	38	0.08	37	36	0.09	32	32	0.19	27	27	0.31
36	1050	72 (22)	69	34	0.06	63	32	0.07	56	29	0.07	49	26	0.08	40	22	0.08
		67 (19)	57	37	0.08	51	34	0.08	44	31	0.08	36	28	0.08	27	24	0.08
		62 (17)	46	39	0.08	40	37	0.08	34	34	0.08	30	30	0.18	25	25	0.30
	1200	72 (22)	73	36	0.08	67	34	0.08	60	31	0.09	52	28	0.09	42	24	0.09
		67 (19)	61	40	0.09	54	37	0.09	47	34	0.10	39	30	0.10	29	27	0.09
		62 (17)	50	43	0.09	43	40	0.09	37	37	0.10	33	33	0.21	28	28	0.33
	1350	72 (22)	77	39	0.10	71	36	0.10	63	33	0.10	55	30	0.11	45	26	0.11
		67 (19)	64	42	0.11	57	40	0.11	50	36	0.11	41	33	0.11	31	29	0.11
		62 (17)	52	46	0.11	46	43	0.11	41	41	0.13	36	36	0.24	30	30	0.35

CFM – Cubic Ft per Minute EWB – Entering Wet Bulb °F (°C) LWB – Leaving Wet Bulb °F (°C) TC – Gross Cooling Capacity 1000 Btuh
 SHC – Gross Sensible Capacity 1000 Btuh BF – Bypass Factor MBH – 1000 Btuh

NOTES:

- Contact manufacturer for cooling capacities at conditions other than shown in table.
- Formulas:
 Leaving db = entering db - $\frac{\text{sensible heat cap.}}{1.09 \times \text{CFM}}$
 Leaving wb = wb corresponding to enthalpy of air leaving coil (h_{lwb})
 $h_{lwb} = h_{ewb} - \frac{\text{total capacity (Btuh)}}{4.5 \times \text{CFM}}$
 where h_{ewb} = enthalpy of air entering coil. Direct interpolation is permissible. Do not extrapolate.
- SHC is based on 80°F (27°C) db temperature of air entering coil. Below 80°F (27°C) db, subtract (Correction Factor x CFM) from SHC. Above 80°F (27°C) db, add (Correction Factor x CFM) to SHC.
- Bypass Factor = 0 indicates no psychometric solution. Use bypass factor of next lower EWB for approximation.

SHC CORRECTION FACTOR

BYPASS FACTOR	ENTERING AIR DRY-BULB TEMPERATURE (°F)					
	79	78	77	76	75	Under 75
	81	82	83	84	85	Over 85
BYPASS FACTOR	ENTERING AIR DRY-BULB TEMPERATURE (°C)					
	26	25	25	24	24	Under 75
	27	28	28	29	29	Over 85
Correction Factor						
0.10	.098	1.96	2.94	3.92	4.91	Use formula shown below
0.20	0.87	1.74	2.62	3.49	4.36	
0.30	0.76	1.53	2.29	3.05	3.82	

Interpolation is permissible.
 Correction Factor = $1.09 \times (1 - \text{BF}) \times (\text{db} - 80)$

PERFORMANCE DATA (CONT.)

ESTIMATED SOUND POWER LEVEL (dBA)

UNIT SIZE	CONDITIONS		OCTAVE BAND CENTER FREQUENCY						
	CFM	Ext Static Pressure	63	125	250	500	1000	2000	4000
18	600	0.18	47.9	51.6	46.6	49.6	47.6	38.7	34.7
24	800	0.18	47.9	51.3	50.7	51.1	46.9	41.6	35.7
30	1000	0.24	47.9	55.7	50	54.3	51.9	43.8	39.3
36	1200	0.24	47.9	55.6	49.2	53.1	49.6	43.4	38.2

* Estimated sound power levels have been derived using the method described in the 1987 ASHRAE HVAC Systems & Applications Handbook, Chapter 52, p. 52.7.

ELECTRIC DATA WITH OPTIONAL FIELD-INSTALLED ELECTRIC HEAT

HEAT KIT MODEL	USED ON SIZE	NOMINAL HEAT CAPACITY @ 240V	HEATER CAPACITY (MBH)		MINIMUM CIRCUIT AMPACITY (MCA)		MAX. FUSE OR BREAKER HEAT KIT AMPACITY (HACR)		MIN. WIRE SIZE (AWG) ††		MIN. GROUND WIRE SIZE		MAX. WIRE LENGTH (Ft) ††	
			KW	208	240	208	240	208	240	208	240	208	240	208
EHK3-03B	18	3	7.7	10.2	14.8	16.9	20	20	12	12	10	10	72	73
EHK3-05B		5	12.8	17.1	23.9	27.3	30	30	10	10	10	10	72	73
EHK3-06B		6	15.4	20.5	28.4	32.6	35	35	8	8	10	10	98	96
EHK3-08B		7.5	19.3	25.7	35.2	40.4	50	50	8	8	10	10	78	79
EHK3-10B		10	24.7	32.8	44.6	51.3	60	60	6	6	10	10	94	96
EHK3-03B	24	3	7.7	10.2	14.8	16.9	20	20	12	12	10	10	72	73
EHK3-05B		5	12.8	17.1	23.9	27.3	30	30	10	10	10	10	72	73
EHK3-06B		6	15.4	20.5	28.4	32.6	35	35	8	8	10	10	98	96
EHK3-08B		7.5	19.3	25.7	35.2	40.4	50	50	8	8	10	10	78	79
EHK3-10B		10	24.7	32.8	44.6	51.3	60	60	6	6	10	10	94	96
EHK3-03B	30	3	7.7	10.2	15.8	17.9	20	20	12	12	10	10	67	69
EHK3-05B		5	12.8	17.1	24.9	28.3	30	30	10	10	10	10	69	71
EHK3-06B		6	15.4	20.5	29.4	33.5	35	35	8	8	10	10	94	93
EHK3-08B		7.5	19.3	25.7	36.1	41.4	50	50	8	8	10	10	76	77
EHK3-10B		10	24.7	32.8	45.5	52.3	60	60	6	6	10	10	92	94
EHK3-03B	36	3	7.7	10.2	15.8	17.9	20	20	12	12	10	10	67	69
EHK3-05B		5	12.8	17.1	24.9	28.3	30	30	10	10	10	10	69	71
EHK3-06B		6	15.4	20.5	29.4	33.5	35	35	8	8	10	10	94	93
EHK3-08B		7.5	19.3	25.7	36.1	41.4	50	50	8	8	10	10	76	77
EHK3-10B		10	24.7	32.8	45.5	52.3	60	60	6	6	10	10	92	94

* †† Copper wire must be used. If other than uncoated (non-plated), 75°C ambient, copper wire (solid wire for 10 AWG and smaller, stranded wire for larger than 10 AWG) is used, consult applicable tables of the National Electric Code (ANSI/NGPA 70).

* †† Length shown is as measured 1 way along wire path between unit and service panel for a voltage drop not to exceed 2%.

OTHER ACCESSORIES

Kit Number	Description	Used on sizes
KFAGP0101LGL	Louvered Panel with Filter Rack	18, 24
KFAGP0201LGL	Louvered Panel with Filter Rack	30, 36
KFAGP0101COV	Access Panel	18, 24
KFAGP0201COV	Access Panel	30, 36
KSATX0601HSO	TXV Kit R-22	18, 24, 30, 36
KSATX201PUR	TXV Kit Puron (R-410A)	18, 24, 30
KSATX301PUR	TXV Kit Puron (R-410A)	36
KFAET0150ETK	PVC Condensate Trap Kit (50 pack)	All