

40MKCF / 24AHA4 / 124ANS
40MKQF / 25HHA4 / 224ANS
Under Ceiling/Floor Console Ductless System
Sizes 18 to 54

Product Data



INDUSTRY LEADING FEATURES / BENEFITS

A PERFECT BALANCE BETWEEN BUDGET LIMITS, ENERGY SAVINGS AND COMFORT.

The MK series ductless split systems are a matched combination of an outdoor condensing unit and an indoor fan coil unit connected only by refrigerant tubing and wires.

The fan coil is mounted under the ceiling or on the wall, near the ceiling. This selection of fan coils permits inexpensive and creative solutions to design problems such as:

- Add-ons to current space (an office or family room addition)
- Special space requirements
- When changes in the load cannot be handled by the existing system.
- When adding air conditioning to spaces that are heated by hydronic or electric heat and have no ductwork.
- Historical renovations or any application where preserving the look of the original structure is essential.
- The ideal compliment to your ducted system when it is impractical or prohibitively expensive to use ductwork.

These compact indoor fan coil units take up very little space in the room and do not obstruct windows. The fan coils are attractively styled to blend with most room decors. Advanced system components incorporate innovative technology to provide reliable cooling performance at low sound levels.

LOW SOUND LEVELS

When noise is a concern, the ductless systems are the answer. The indoor units are whisper quiet. There are no compressors indoors, either in the conditioned space or directly over it, and there is none of the noise usually generated by air being forced through ductwork.

When sound ordinances and proximity to neighbors demand quiet operation, the 24AHA4/25HHA4/124ANS/224ANS unit is the right choice: The advanced, horizontal blow-through airflow design distributes air more evenly over the coil.

SECURE OPERATION

If security is an issue, outdoor and indoor units are connected only by refrigerant piping and wiring to prevent intruders from crawling through ductwork.

In addition, since 24AHA4/25HHA4/124ANS/224ANS units can be installed close to an outside wall, coils are protected from vandals and severe weather.

FAST INSTALLATION

This compact ductless split system is simple to install. A mounting bracket is standard with the indoor units and only wire and piping need to be run between indoor and outdoor units. These units are fast and easy to install ensuring minimal disruption to customers in the home or workplace. This makes the MK ductless split systems the equipment of choice, especially in retrofit situations.

SIMPLE SERVICING AND MAINTENANCE

Removing the top panel on outdoor units provides immediate access to the control compartment, providing a service technician access to check unit operation. In addition, the draw through design of the outdoor section means that dirt accumulates on the outside surface of the coil. Coils can be cleaned quickly from the inside using a pressure hose and detergent.

On all indoor units, service and maintenance expense is reduced due to easy-to-access cleanable filters. In addition, these ductless systems have extensive self-diagnostics to assist in troubleshooting.

BUILT-IN RELIABILITY

Ductless split system indoor and outdoor units are designed to provide years of trouble-free operation.

The indoor units include protection against freeze-up and high evaporator temperatures on heat pumps.

The condensing units and heat pumps are also protected. There is a 3-minute time delay before the compressor will re-start. An oversized accumulator (Heat Pump), high pressure switches (or liquid line pressure switch on the heat pump), and compressor internal overload protection will ensure a reliable system that is ideal for light commercial applications.

INDIVIDUAL ROOM COMFORT

Maximum comfort is provided because each space can be controlled individually based on usage pattern. The air sweep feature provided permits optimal room air mixing to eliminate hot and cold spots for occupant comfort. In addition, year-round comfort can be provided with heat pumps.

ECONOMICAL OPERATION

The ductless split system design allows individual room heating or cooling when required. There is no need to run large supply-air fans or chilled water pumps to handle a few spaces with unique load patterns. In addition, because air is moved only in the space required, no energy is wasted moving air through ducts.

EASY-TO-USE CONTROLS

The ductless units have microprocessor-based controls to provided the ultimate in comfort and efficiency. The user friendly wireless remote control provides the interface between user and the unit.

FLEXIBILITY

A variety of accessories simplify the installation process and help meet system requirements and weather conditions. See Table 2 on page 4 for available accessories.

AGENCY LISTINGS

All systems are listed with AHRI (Air Conditioning, Heating & Refrigeration Institute).

MODEL NUMBER NOMENCLATURE

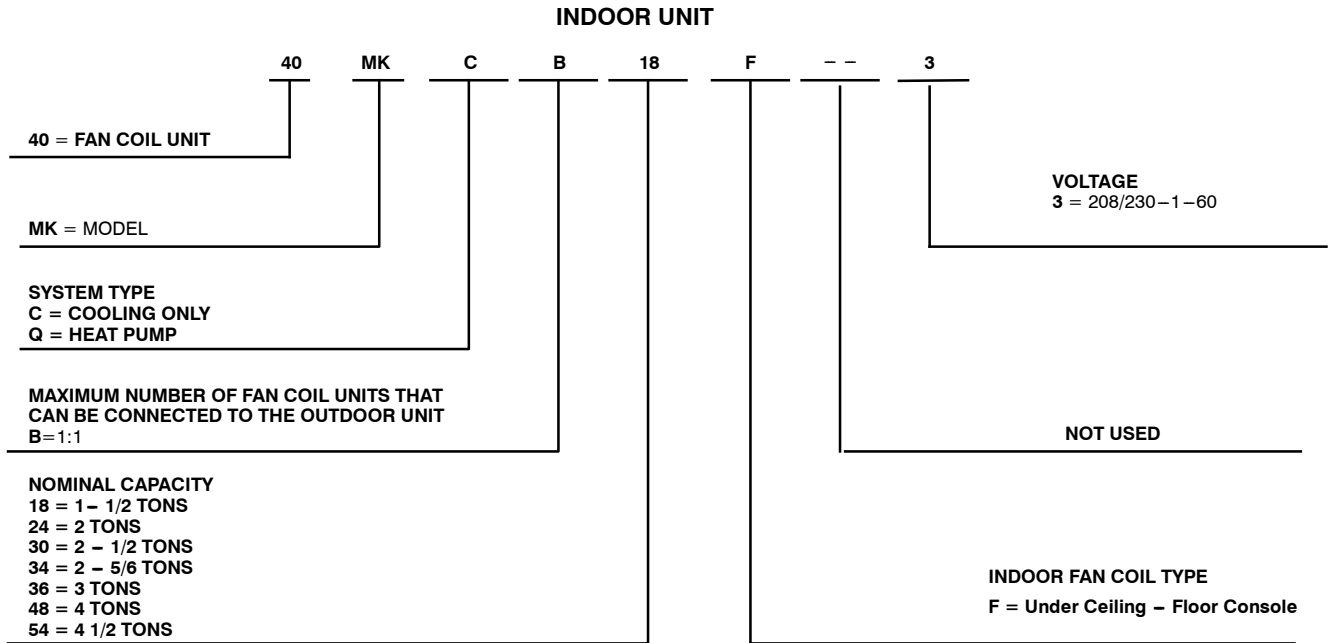

Use of the AHRI Certified TM Mark indicates a manufacturer's participation in the program For verification of certification for individual products, go to www.ahridirectory.org.



STANDARD FEATURES AND ACCESSORIES

Table 1 – Standard Features and Accessories

Ease Of Installation	
Indoor and Outdoor Compact Size	S
Outdoor Unit Wall Mounting Kit	A
Outdoor Unit Stacking Kit	A
Indoor Mounting Bracket	S
Comfort Features	
Convertible Under Ceiling – Floor Console	S
Microprocessor Controls	
Wireless Remote Control	S
Automatic Air Sweep	S
Air Direction Control	S
Auto Restart Function	S
Cold Blow Protection On Heat Pumps	S
Turbo Mode	S
Silence Mode	S
Follow Me	S
Energy Saving Features	
Sleep Mode	S
Stop/Start Timer	S
46 ° F Heating Mode (Heating Setback)	S
Safety And Reliability	
3 Minute Time Delay For Compressor	S
Over Current Protection For Compressor	S
Crankcase Heater (standard on sizes 30 and 36 Heat Pump)	A
Indoor Coil Freeze Protection	S
Indoor Coil High Temperature Protection On Heat Pumps	S
Condenser High Temperature Protection On Heat Pumps	S
Accumulator On Heat Pumps	S
Ease Of Service And Maintenance	
Cleanable Filters	S
Diagnostics	S
Liquid Line Pressure Taps	S
Suction And Discharge Pressure Taps	S
Application Flexibility	
Low Ambient Controls (-20F) (-28.9C)	A
3-Phase on sizes 34 & 54 (AC) and 36 & 48 (HP)	S
Wind Baffles	A
Condensate Pumps	A
Wired Controls	A

Legend

- S Standard
- A Accessory

Table 2 – Optional Accessories

Ordering No.	Descriptions	For Models
KSACN0101AAA	Wired Remote Control	All Sizes
53DS-900---118	Condensate Pump (230v)	All Sizes
KSALA0801AAA	Low Ambient Control (for cooling - 20F)	24AHA4/25HHA4 (208/230V)
KSALA0901AAA	Low Ambient Control (for cooling - 20F)	24AHA4 (460V-3)
KAACH1401AAA	Crankcase Heater	24AHA4 Sizes 18-36 (208/230V)
KAACH1501AAA	Crankcase Heater	24AHA4 Size 36 (460V-3)
KAACH1201AAA	Crankcase Heater	24AHA4 Size 48 (208/230V)
KAACH1901AAA	Crankcase Heater	24AHA4/25HHA4 Size 48 (460V-3)
KAACH1601AAA	Crankcase Heater	25HHA4 Size 48 (208/230V)
KAAWS0101AAA	Winter Start Kit (for low ambient on cooling only systems)	24AHA4 All Sizes
KHAIR0201AAA	Isolation Relay (Required when using Low Ambient cooling with HP)	25HHA4 All Sizes
KSAHS1501AAA	Hard Start Kit (Capacitor & Relay)	24AHA4/25HHA4 (208/230V-1)
53DS-900---087	Wind Baffle	24AHA4 Sizes 18 & 24
53DS-900---071	Wind Baffle	24AHA4 Sizes 30-48 / 25HHA4 Sizes 30 & 36
53DS-900---088	Wind Baffle	25HHA4 Size 48
53DS-900---075	Stacking Kit	24AHA4 Sizes 18, 24
53DS-900---076	Stacking Kit	24AHA4 Sizes 30 - 48
53DS-900---077	Wall Mount Kit	24AHA4 Sizes 18, 24
53DS-900---078	Wall Mount Kit	24AHA4/25HHA4 Sizes 30 - 48
KAALS0201LLS	Liquid Line Solenoid for Cooling Only	24AHA4 All Sizes - Required for Long Line Applications
KHALS0401LLS	Liquid Line Solenoid for Heat Pump	25HHA4 All Sizes - Required for Long Line Applications

INDOOR UNIT ACCESSORIES

Condensate Pump

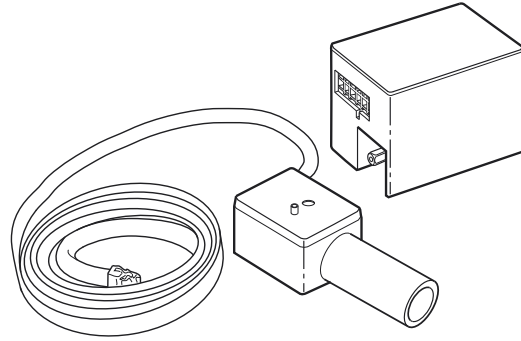

A07892

Fig. 1 – Condensate Pump Accessory

On ductless fan coils, the condensate pump has a lift capability of 12 ft (3.6 m) on the discharge side with the pump mounted in the fan coil or 6 ft (1.8 m) on the suction side if the pump is remote mounted. The pump is recommended when adequate drain line pitch cannot be provided, or when the condensate must move up to exit.

Wired Remote Controller

For applications where the use of wireless remote control is not desired, the MK units can be controlled by means of a wired wall-mounted control with an LCD display.



Fig. 2 – Wall Mounted Control with LCD Display

OUTDOOR UNIT ACCESSORIES

Low Ambient Kit

A fan-speed control device activated by a temperature sensor, designed to control condenser fan motor speed in response to the saturated condensing temperatures down to -20°F (-28.9°C), it maintains condensing temperature at $-100\text{F} \pm 10\text{F}$ ($37.8\text{C} \pm 6\text{C}$). A MotorMaster Low-Ambient Controller or Low-Ambient Pressure Switch must be used when cooling operation is used at outdoor temperatures below 55°F (12.8°C), and can be used on all outdoor units without changing the outdoor fan motor.

Winter Start Control

The Winter Start Control is a SPST delay relay. The control bypasses the low pressure switch for approximately 3 minutes to permit start-up for cooling operation under low load conditions at low ambient temperatures. This relay is recommended on cooling only systems that have the accessory Low Ambient Kit.

Isolation Relay

The Isolation Relay must be used when Low Ambient Kit is used with heat pumps to ensure the pressure switch is bypassed when unit is running in heat pump mode.

Liquid Line Solenoid Valve

The Liquid Line Solenoid Valve is an electrically operated shut-off valve that is installed at the outdoor unit to stop and start refrigerant flow in response to compressor operation. The valve maintains a column of refrigerant in the liquid line between compressor operating cycles and is required for certain long line applications and to improve system performance.

Crankcase Heater

The Crankcase Heater is available for units with scroll compressors and clamps onto the compressor oil sump. It is recommended for low ambient applications. The Crankcase Heater is standard on sizes 30 and 36 Heat Pump.

Wind Baffles

The Wind Baffle is a sheet metal shield used to provide improved unit operation during high winds and is recommended whenever the low ambient accessory is used.

Stacking Kit

Stacking Kits allow stacking of equally sized units or permit smaller units to be stacked on top of larger units.

NOTE: THIS KIT CANNOT BE USED WITH HEAT PUMPS.

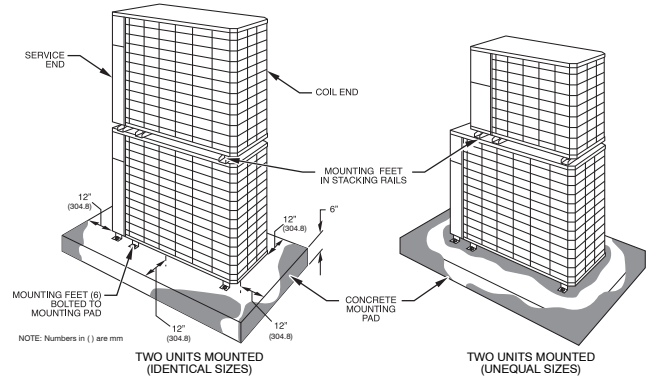

A06417

Fig. 3 – Stacking Kit

Wall Mounting Kit

Wall mount brackets are mounted on the outside of the structure to raise the unit from ground level, or to mount the unit on a wall adjacent to a sloping roof. Wall mounts are also useful in areas of heavy snowfall or where space is at a premium.

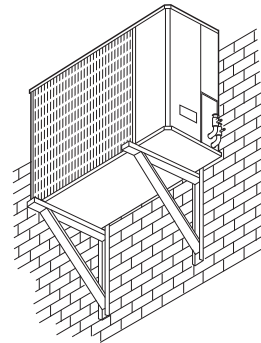

NOTE: Unit must be at least 6 in. (152.4 mm) from wall.

D06006

Fig. 4 – Wall Mounting Kit

DIMENSIONS - INDOOR

Unit:

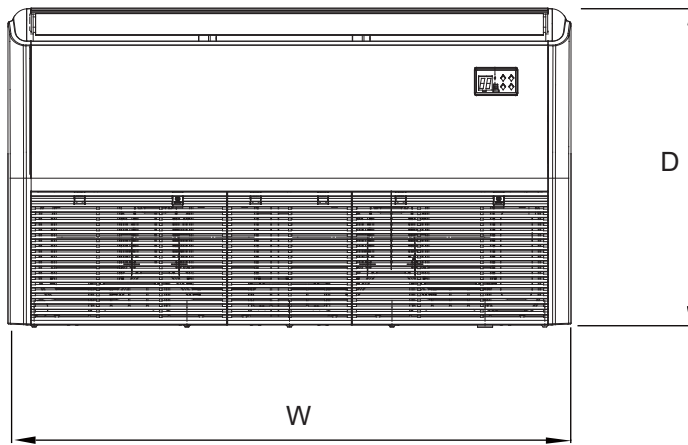

Bracket:

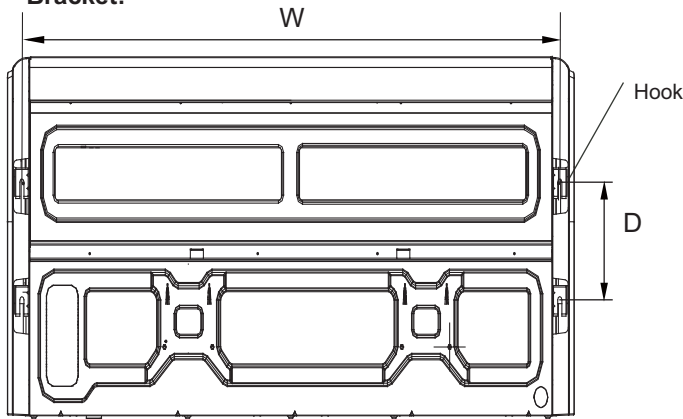

Fig. 5 – 40MKCB**F, 40MKQB**F Unit and Bracket Dimensions

A0150266

Table 3 – Dimensions Indoor

Indoor Unit Size BTU/Hr	Height (H) in (mm)	Width (W) in (mm)	Depth (D) in (mm)	Operating Weight lb (kg)
AC				
18K	9.3 (235)	42.0 (1068)	26.6 (675)	59.7 (27.1)
24K - 34K	9.3 (235)	65.0 (1650)	26.6 (675)	91.9 (41.7)
54K	9.3 (235)	65.0 (1650)	26.6 (675)	98.8 (44.8)
HP				
30K - 48K	9.3 (235)	65.0 (1650)	26.6 (675)	98.8 (44.8)
Bracket				
18K AC	-	38.7 (983)	8.7 (220)	-
24K - 54K AC/HP	-	61.6 (1565)	8.7 (220)	-

DIMENSIONS - OUTDOOR

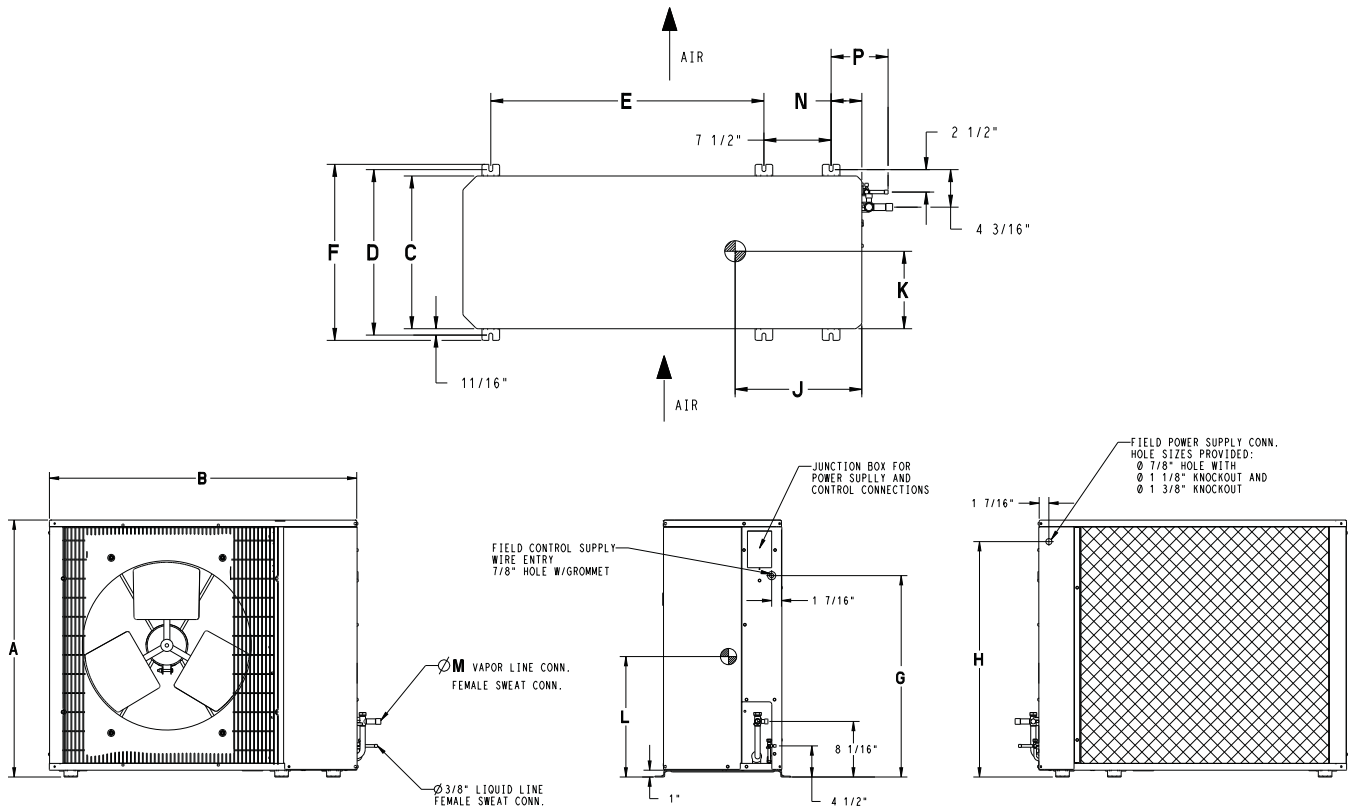

Fig. 6 – Outdoor Unit Dimensions

Table 4 – Dimensions Indoor

	UNIT	Dimensions in (mm)														OPERATING WEIGHT lbs. (kg)
		A	B	C	D	E	F	G	H	J	K	L	M	N	P	
Cooling Only	24AHA418	31.1 (791)	36.9 (938)	14.6 (370)	16 (406)	23.4 (595)	17.2 (437)	23.1 (587)	28.1 (713)	13 (330)	6.6 (168)	11.3 (286)	0.6 (16)	2.9 (73)	5.8 (148)	146 (66)
	24AHA424	31.1 (791)	36.9 (938)	14.6 (370)	16 (406)	23.4 (595)	17.2 (437)	23.1 (587)	28.1 (713)	14 (356)	6.8 (171)	11.6 (295)	0.8 (19)	2.9 (73)	5.8 (148)	148 (67)
	24AHA430	37.1 (943)	44.5 (1130)	17.1 (433)	18.4 (468)	30.5 (775)	19.6 (498)	29.1 (740)	34.1 (865)	13.7 (348)	8.1 (206)	15.9 (403)	0.8 (19)	3.4 (86)	6.4 (162)	183 (83)
	24AHA436	37.1 (943)	44.5 (1130)	17.1 (433)	18.4 (468)	30.5 (775)	19.6 (498)	29.1 (740)	34.1 (865)	13.7 (348)	8.1 (206)	15.9 (403)	0.9 (22)	3.4 (86)	6.4 (162)	184 (83)
	24AHA448	37.1 (943)	44.5 (1130)	17.1 (433)	18.4 (468)	30.5 (775)	19.6 (498)	29.1 (740)	34.1 (865)	14.5 (368)	8.5 (216)	18.9 (479)	0.9 (22)	3.4 (86)	6.4 (162)	213 (97)
Heat Pump	HHA430	37.1 (943)	44.5 (1130)	17.1 (433)	18.4 (468)	30.5 (775)	19.6 (498)	29.1 (740)	34.1 (865)	13.7 (348)	8.1 (206)	15.9 (403)	0.8 (19)	3.4 (86)	5.5 (140)	196 (89)
	HHA436	37.1 (943)	44.5 (1130)	17.1 (433)	18.4 (468)	30.5 (775)	19.6 (498)	29.1 (740)	34.1 (865)	13.7 (348)	8.1 (206)	15.9 (403)	0.9 (22)	3.4 (86)	5.5 (140)	197 (89)
	HHA448	43.1 (1095)	44.5 (1130)	17.1 (433)	18.4 (468)	30.5 (775)	19.6 (498)	35.1 (892)	40.1 (1018)	14.5 (368)	8.5 (216)	18.9 (479)	0.9 (22)	3.4 (86)	5.5 (140)	246 (112)

NOTE: Dimensions shown in feet-inches. Dimensions in () are millimeters.

CLEARANCES - INDOOR

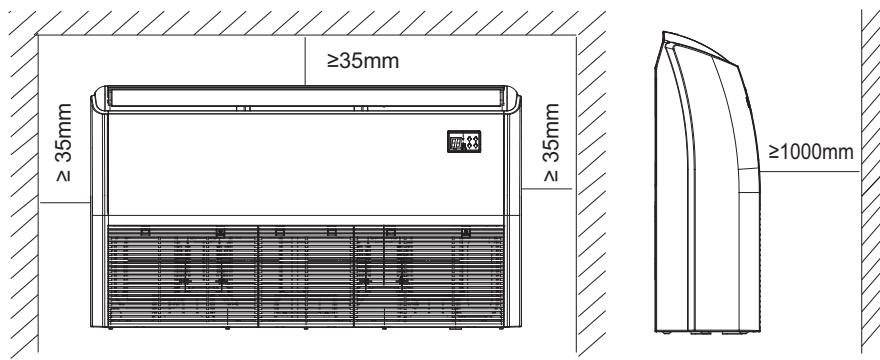

A0150267

Fig. 7 – 40MKCB**F, 40MKQB**F Unit Clearance

CLEARANCES - OUTDOOR

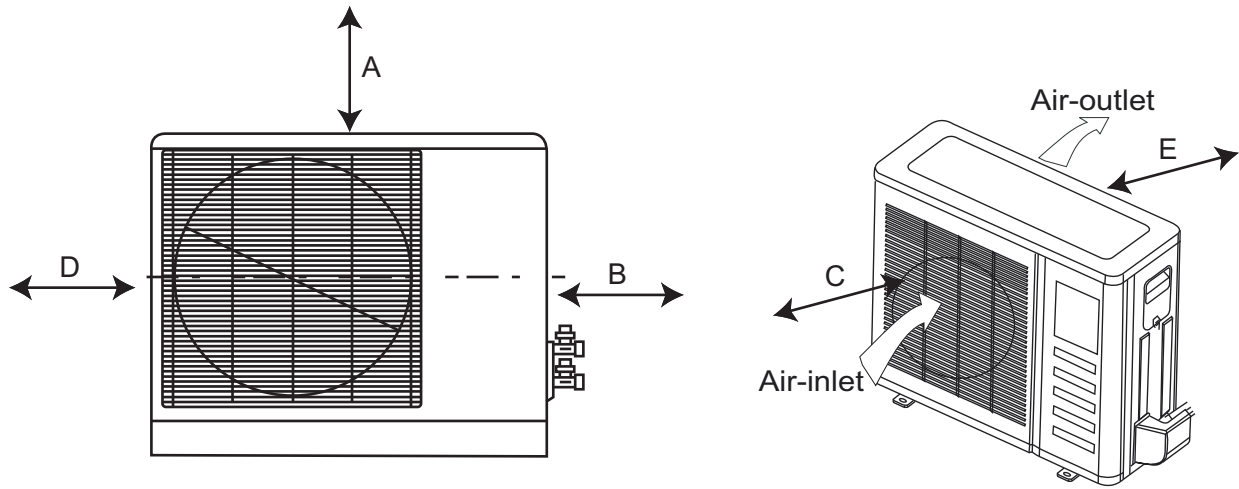

A08436

Fig. 8 – Outdoor Unit Clearance

Table 5 – Clearances

UNIT	Coil Facing Wall - in. (mm)	Fan Facing Wall - in. (mm)
A	24 (610)	24 (610)
B	24 (610)	24 (610)
C	20 (508)	6 (152)
D	6 (152)	8 (203)
E	6 (152)	20 (508)

SPECIFICATIONS

Table 6 – Specifications-Cooling Only Under Ceiling Systems

		Cooling Only Only									
System	Size		18	24	30	34	34	34	54	54	54
	Outdoor Model		24AHA418A003	24AHA424A003	24AHA430A003	24AHA436A003	24AHA436A005	24AHA436A006	24AHA448A003	24AHA448A005	24AHA448A006
	Indoor Model		40MKCB18F--3	40MKCB34F--3	40MKCB34F--3	40MKCB34F--3	40MKCB34F--3	40MKCB34F--3	40MKCB54F--3	40MKCB54F--3	40MKCB54F--3
Performance	Energy Star		NO	NO	NO	NO	NO	NO	NO	NO	NO
	Cooling Rated Capacity	Btu/h	17,100	24,000	28,600	33,200	33,200	33,200	53,000	53,000	53,000
	SEER		14	14	14	14	14	14	14	14	14
Controls	EER		12.2	12.2	12.2	12.2	12.2	12.2	11.7	11.7	11.7
	Wireless Remote Controller (F/ C Convertible)		Standard	Standard	Standard	Standard	Standard	Standard	Standard	Standard	Standard
Operating Range	Wired Remote Controller (F/ C Convertible)		Optional	Optional	Optional	Optional	Optional	Optional	Optional	Optional	Optional
	Cooling Outdoor DB Min - Max	F	55-125 (-20 F w / Low-Ambient Kit)								
Piping	Cooling Indoor DB Min -Max	F	64-90	64-90	64-90	64-90	64-90	64-90	64-90	64-90	64-90
	Total Piping Length	Ft.	200'	200'	200'	200'	200'	200'	200'	200'	200'
	Drop (OD above ID)	Ft.	200'	200'	200'	200'	200'	200'	200'	200'	200'
	Lift (OD below ID)	Ft.	65'	65'	65'	65'	65'	65'	65'	65'	65'
	Outdoor Pipe Connection Size - Liquid	In.	3/8"	3/8"	3/8"	3/8"	3/8"	3/8"	3/8"	3/8"	3/8"
	Outdoor Pipe Connection Size - Suction	In.	5/8"	3/4"	3/4"	7/8"	7/8"	7/8"	7/8"	7/8"	7/8"
Refrigerant	Indoor Pipe Connection Size - Liquid	In.	3/8"	3/8"	3/8"	3/8"	3/8"	3/8"	3/8"	3/8"	3/8"
	Indoor Pipe Connection Size - Suction	In.	5/8"	3/4"	3/4"	3/4"	3/4"	3/4"	3/4"	3/4"	3/4"
Outdoor Coil	Type		R-410A	R-410A	R-410A	R-410A	R-410A	R-410A	R-410A	R-410A	R-410A
	Design Pressure	PSIG	550	550	550	550	550	550	550	550	550
	Metering Device		Type B Accurator								
Indoor Coil	Charge	Lb.	6.4	6.5	8.6	8.9	8.9	8.9	9	9	9
	Face Area	Sq. Ft.	7.3	7.3	12.1	12.1	12.1	12.1	12.1	12.1	12.1
	No. Rows		2	2	2	2	2	2	2	2	2
	Fins per inch		20	20	20	20	20	20	20	20	20
Compressor	Circuits		3	3	3	3	3	3	3	3	3
	Face Area (sq. ft.)	Sq. Ft.	2.5	4.1	4.1	4.1	4.1	4.1	4.35	4.35	4.35
	No. Rows		3	3	3	3	3	3	4	4	4
	Fins per inch		19	19	19	19	19	19	19	19	19
Electrical	Circuits		7	8	8	8	8	8	6	6	6
	Type		Scroll	Scroll	Scroll	Scroll	Scroll	Scroll	Scroll	Scroll	Scroll
Outdoor	Model		ZP16K6E-PFV-130	ZP20K6E-PFV-130	ZP25K5E-PFV-130	ZP29K5E-PFV-130	ZP29K5E-TF5-130	ZP29K5E-TFD-130	ZP40K6E-PFV-130	ZP40K6E-TF5-130	ZP40K6E-TFD-130
	Outdoor Voltage, Phase, Cycle	V/Ph/Hz	208/230-1-60	208/230-1-60	208/230-1-60	208/230-1-60	208/230-3-60	460-3-60	208/230-1-60	208/230-3-60	460-3-60
	Indoor Voltage, Phase, Cycle	V/Ph/Hz	208/230-1-60	208/230-1-60	208/230-1-60	208/230-1-60	208/230-1-60	208/230-1-60	208/230-1-60	208/230-1-60	208/230-1-60
	Power Supply		Indoor and outdoor units have dedicated power supply								
	MCA (Outdoor)	A.	11.8	14.1	18.3	18.8	12.5	7.6	24.3	18.3	8.4
	MOCP - Fuse Rating (Outdoor)	A.	20	25	30	30	20	15	40	30	15
Indoor	MCA (Indoor)	A.	3	3	3	3	3	3	3	3	3
	MOCP - Fuse Rating (Indoor)	A.	15	15	15	15	15	15	15	15	15
	Unit Width	In.	36.9	36.9	44.5	44.5	44.5	44.5	44.5	44.5	44.5
	Unit Height	In.	31.1	31.1	37.1	37.1	37.1	37.1	37.1	37.1	37.1
	Unit Depth	In.	14.6	14.6	17.1	17.1	17.1	17.1	17.1	17.1	17.1
	Net Weight	Lbs.	146	148	183	184	184	184	213	213	213
Indoor	Airflow	CFM	1,285	1,285	1,900	2,615	2,615	2,615	2,615	2,615	2,615
	Unit Width	In.	42.0	65.0	65.0	65.0	65.0	65.0	65.0	65.0	65.0
	Unit Height	In.	9.3	9.3	9.3	9.3	9.3	9.3	9.3	9.3	9.3
	Unit Depth	In.	26.6	26.6	26.6	26.6	26.6	26.6	26.6	26.6	26.6
	Net Weight	Lbs.	59.7	91.9	91.9	91.9	91.9	91.9	98.8	98.8	98.8
	Number of Fan Speeds		3	3	3	3	3	3	3	3	3
	Airflow (lowest to highest)	CFM	405/515/695	975/1335/1130	975/1335/1130	975/1335/1130	975/1335/1130	975/1335/1130	1310/1400/1470	1310/1400/1470	1310/1400/1470
Air throw Data	Sound Pressure (lowest to highest)	dB(A)	42/48/53	50/52/55	50/52/55	50/52/55	50/52/55	50/52/55	55/57/59	55/57/59	55/57/59
	Air throw Data	Ft.	26	29	29	29	29	29	29	29	29

* Liquid line needs to be insulated

** Refer to Ductless Split System Long Line Guide for additional information. Long Line accessories required beyond 80 ft (24.4 m).

SPECIFICATIONS (CONT)

Table 7 – Specifications - Heat Pump Under Ceiling Systems

		HEAT PUMP								
System			30	36	36	36	48	48	48	
System	Size									
	Outdoor Model		25HHA430A003 224ANS030000	25HHA436A003 224ANS036000	25HHA436A005 224APS036000	25HHA436A006 224AES036000	25HHA448A003 224ANS048000	25HHA448A005 224APS048000	25HHA448A006 224AES048000	
	Indoor Model		40MKQB36F--3	40MKQB36F--3	40MKQB36F--3	40MKQB36F--3	40MKQB48F--3	40MKQB48F--3	40MKQB48F--3	
Energy Star			NO	NO	NO	NO	NO	NO	NO	
Performance	Cooling Rated Capacity	Btu/h	29,000	34,200	34,200	34,200	46,400	46,400	46,400	
	SEER		14	14	14	14	14	14	14	
	EER		11.5	11	11	11	11.7	11.7	11.7	
	Heating Rated Capacity	Btu/h	29,000	34,200	34,200	34,200	46,400	46,400	46,400	
	HSPF		8.2	8.2	8.2	8.2	8.2	8.2	8.2	
	COP	W/W	4.1	4.1	4.1	4.1	3.8	3.8	3.8	
Controls	Wireless Remote Controller (°F/°C Convertible)		Standard	Standard	Standard	Standard	Standard	Standard	Standard	
	Wired Remote Controller (°F/°C Convertible)		Optional	Optional	Optional	Optional	Optional	Optional	Optional	
Operating Range	Cooling Outdoor DB Min - Max	°F	55-125 (-20°F w / Low-Ambient Kit)							
	Heating Outdoor DB Min - Max	°F	17-75	17-75	17-75	17-75	17-75	17-75	17-75	
	Cooling Indoor DB Min -Max	°F	64-90	64-90	64-90	64-90	64-90	64-90	64-90	
	Heating Indoor DB Min -Max	°F	32-80	32-80	32-80	32-80	32-80	32-80	32-80	
Piping	Total Piping Length	Ft.	200'	200'	200'	200'	200'	200'	200'	
	Drop (OD above ID)	Ft.	200'	200'	200'	200'	200'	200'	200'	
	Lift (OD below ID)	Ft.	65'	65'	65'	65'	65'	65'	65'	
	Outdoor Pipe Connection Size - Liquid	In.	3/8"	3/8"	3/8"	3/8"	3/8"	3/8"	3/8"	
	Outdoor Pipe Connection Size - Suction	In.	3/4"	7/8"	7/8"	7/8"	7/8"	7/8"	7/8"	
	Indoor Pipe Connection Size - Liquid	In.	3/8"	3/8"	3/8"	3/8"	3/8"	3/8"	3/8"	
	Indoor Pipe Connection Size - Suction	In.	3/4"	3/4"	3/4"	3/4"	3/4"	3/4"	3/4"	
Refrigerant	Type		R-410A	R-410A	R-410A	R-410A	R-410A	R-410A	R-410A	
	Design Pressure	PSIG	550	550	550	550	550	550	550	
	Metering Device		Type B Accurator							
	Charge	Lb.	12.1	12.3	12.3	12.3	10.95	10.95	10.95	
Outdoor Coil	Face Area	Sq. Ft.	12.1	12.1	12.1	12.1	14.1	14.1	14.1	
	No. Rows		2	2	2	2	2	2	2	
	Fins per inch		20	20	20	20	20	20	20	
	Circuits		6	5	5	5	6	6	6	
Indoor Coil	Face Area (sq. ft.)	Sq. Ft.	4.4	4.4	4.4	4.4	4.4	4.4	4.4	
	No. Rows		4	4	4	4	4	4	4	
	Fins per inch		19	19	19	19	19	19	19	
	Circuits		6	6	6	6	6	6	6	
Compressor	Type		Scroll	Scroll	Scroll	Scroll	Scroll	Scroll	Scroll	
	Model		ZP24K5E-PFV-1 30	ZP29K5E-PFV-1 30	ZP29K5E-TF5-1 30	ZP29K5E-TFD-1 30	ZP42K5E-PFV-1 30	ZP42K5E-TF5-1 30	ZP42K5E-TFD-1 30	
Electrical	Outdoor Voltage, Phase, Cycle	V/Ph/Hz	208/230-1-60	208/230-1-60	208/230-3-60	460-3-60	208/230-1-60	208/230-3-60	460-3-60	
	Indoor Voltage, Phase, Cycle	V/Ph/Hz	208/230-1-60	208/230-1-60	208/230-1-60	208/230-1-60	208/230-1-60	208/230-1-60	208/230-1-60	
	Power Supply		Indoor and outdoor units have dedicated power supply							
	MCA (Outdoor)	A.	17.2	19	12.8	7.6	28.8	18.6	8.6	
	MOCP - Fuse Rating (Outdoor)	A.	30	30	20	15	50	30	15	
	MCA (Indoor)	A.	3	3	3	3	3	3	3	
Outdoor	Unit Width	In.	44.5	44.5	44.5	44.5	44.5	44.5	44.5	
	Unit Height	In.	37.1	37.1	37.1	37.1	43.1	43.1	43.1	
	Unit Depth	In.	17.1	17.1	17.1	17.1	17.1	17.1	17.1	
	Net Weight	Lbs.	196	197	197	197	246	246	246	
	Airflow	CFM	2,615	2,615	2,615	2,615	2,785	2,785	2,785	
	Indoor	Unit Width	In.	65.0	65.0	65.0	65.0	65.0	65.0	65.0
Unit Height		In.	9.3	9.3	9.3	9.3	9.3	9.3	9.3	
Unit Depth		In.	26.6	26.6	26.6	26.6	26.6	26.6	26.6	
Net Weight		Lbs.	98.8	98.8	98.8	98.8	98.8	98.8	98.8	
No. of Fan Speeds			3	3	3	3	3	3	3	
Airflow (lowest to highest)		CFM	1310/1400/1470	1310/1400/1470	1310/1400/1470	1310/1400/1470	1310/1400/1470	1310/1400/1470	1310/1400/1470	
Sound Pressure (lowest to highest)	dB(A)	55/57/59	55/57/59	55/57/59	55/57/59	55/57/59	55/57/59	55/57/59		
Air throw Data	Ft.	29	29	29	29	29	29	29		

* Liquid line needs to be insulated

** Refer to Ductless Split System Long Line Guide for additional information. Long Line accessories required beyond 80 ft (24.4 m).

COOLING PERFORMANCE DATA - COOLING ONLY UNITS

Table 8 – Cooling Performance Data - Cooling Only Units

SIZE	INDOOR UNIT	OUTDOOR UNIT	CONDENSER ENTERING AIR TEMPERATURES deg F																						
			EVAPORATOR AIR		75		85		95		105		115		125										
			CFM	EWB	Capacity MBtu/h	Total System KW**	Capacity MBtu/h	Total System KW**	Capacity MBtu/h	Total System KW**	Capacity MBtu/h	Total System KW**	Capacity MBtu/h	Total System KW**	Capacity MBtu/h	Total System KW**									
18	40MKCB18F--3	24AHA419A003 124ANS018000	405	72	18.58	9.28	1.08	17.83	8.97	1.20	17.04	8.65	1.34	16.18	8.30	1.49	15.25	7.93	1.67	14.23	7.53	1.88			
				67	16.85	10.96	1.07	16.16	10.65	1.20	15.44	10.32	1.33	14.67	9.98	1.49	13.83	9.61	1.49	12.80	9.24	1.67	11.95	8.85	1.88
				62	15.28	12.61	1.07	14.65	12.29	1.19	13.99	11.97	1.33	13.29	11.63	1.49	12.53	11.26	1.67	11.71	10.87	1.88			
				57	14.07	14.07	1.07	13.61	13.61	1.19	13.12	13.12	1.33	12.59	12.59	1.49	12.01	12.01	1.67	11.38	11.38	1.88			
				72	19.69	10.20	1.10	18.85	9.87	1.22	17.95	9.53	1.36	16.99	9.16	1.52	15.95	8.77	1.70	14.82	8.34	1.90			
				67	17.87	12.35	1.10	17.10	12.02	1.22	16.29	11.67	1.36	15.42	11.30	1.52	14.48	10.91	1.70	13.45	10.49	1.90			
				63	16.56	11.90	1.10	15.84	11.56	1.22	15.09	11.22	1.36	14.28	10.85	1.52	13.42	10.47	1.70	12.47	10.05	1.90			
				62	16.23	14.47	1.10	15.52	14.13	1.22	14.79	13.77	1.36	14.01	13.39	1.52	13.19	12.96	1.70	12.36	12.36	1.90			
				57	15.49	15.49	1.10	14.94	14.94	1.22	14.37	14.37	1.36	13.76	13.76	1.51	13.09	13.09	1.69	12.34	12.34	1.90			
				72	20.80	11.56	1.14	19.84	11.21	1.27	18.83	10.84	1.40	17.76	10.45	1.56	16.60	10.03	1.74	15.35	9.59	1.94			
				67	18.89	14.47	1.14	18.02	14.12	1.26	17.10	13.75	1.40	16.12	13.35	1.56	15.08	12.93	1.74	13.95	12.46	1.94			
				63	17.52	13.87	1.14	16.71	13.52	1.26	15.86	13.14	1.40	14.96	12.75	1.56	13.99	12.33	1.74	12.95	11.87	1.94			
62	17.28	17.13	1.14	16.57	16.57	1.26	15.88	15.88	1.40	15.15	15.15	1.56	14.35	14.35	1.74	13.46	13.46	1.94							
57	17.19	17.19	1.14	16.55	16.55	1.26	15.86	15.86	1.40	15.13	15.13	1.56	14.33	14.33	1.74	13.45	13.45	1.94							
72	28.43	16.34	1.54	27.06	15.84	1.70	25.60	15.32	1.88	24.05	14.76	2.09	22.39	14.18	2.32	20.63	13.56	2.59							
67	25.90	20.75	1.53	24.64	20.24	1.69	23.33	19.71	1.87	21.92	19.14	2.08	20.42	18.52	2.31	18.84	17.84	2.58							
63	24.10	19.88	1.52	22.93	19.37	1.68	21.71	18.84	1.87	20.42	18.27	2.07	19.04	17.65	2.31	17.58	16.96	2.58							
62	24.08	24.08	1.52	23.13	23.13	1.69	22.11	22.11	1.87	21.02	21.02	2.07	19.83	19.83	2.31	18.53	18.53	2.58							
57	24.05	24.05	1.52	23.10	23.10	1.69	22.09	22.09	1.87	21.00	21.00	2.07	19.81	19.81	2.31	18.51	18.51	2.58							
72	28.86	17.43	1.58	27.43	16.92	1.74	25.92	16.38	1.92	24.31	15.82	2.13	22.59	15.22	2.36	20.77	14.58	2.63							
67	26.31	22.48	1.57	25.01	21.95	1.73	23.65	21.38	1.91	22.20	20.77	2.12	20.88	20.07	2.35	19.11	19.11	2.62							
63	24.50	21.48	1.57	23.29	20.95	1.73	22.03	20.38	1.91	20.71	19.76	2.11	19.31	19.04	2.35	17.92	17.92	2.62							
62	25.08	25.08	1.57	24.05	24.05	1.73	22.96	22.96	1.91	21.77	21.77	2.12	20.49	20.49	2.35	19.09	19.09	2.62							
57	25.05	25.05	1.57	24.02	24.02	1.73	22.93	22.93	1.91	21.75	21.75	2.12	20.47	20.47	2.35	19.08	19.08	2.62							
72	29.24	18.81	1.63	27.75	18.29	1.79	26.18	17.74	1.98	24.51	17.16	2.18	22.73	16.55	2.41	20.85	15.91	2.68							
67	26.72	24.65	1.62	25.39	24.07	1.79	24.00	23.41	1.97	22.57	22.57	2.17	21.18	21.18	2.41	19.68	19.68	2.68							
63	24.91	23.47	1.62	23.68	22.87	1.78	22.40	22.18	1.96	21.14	21.14	2.17	19.83	19.83	2.40	18.42	18.42	2.67							
62	26.12	26.12	1.62	25.01	25.01	1.78	23.82	23.82	1.97	22.54	22.54	2.17	21.16	21.16	2.41	19.66	19.66	2.67							
57	26.10	26.10	1.62	24.99	24.99	1.78	23.80	23.80	1.97	22.52	22.52	2.17	21.14	21.14	2.41	19.64	19.64	2.67							
72	33.46	17.95	1.84	31.93	17.37	2.04	30.31	16.77	2.27	28.57	16.12	2.52	26.87	15.42	2.80	24.60	14.67	3.11							
67	30.40	22.13	1.82	29.01	21.55	2.02	27.54	20.95	2.24	25.96	20.30	2.49	24.22	19.60	2.78	22.32	18.83	3.10							
63	28.18	21.26	1.80	26.90	20.69	2.00	25.55	20.09	2.22	24.07	19.44	2.47	22.46	18.74	2.76	20.69	17.97	3.09							
62	27.64	26.15	1.79	26.42	25.52	1.99	25.14	24.81	2.22	23.84	23.84	2.47	22.54	22.54	2.76	21.10	21.10	3.09							
57	27.00	27.00	1.79	26.02	26.02	1.99	24.97	24.97	2.22	23.81	23.81	2.47	22.52	22.52	2.76	21.08	21.08	3.09							
72	34.21	19.05	1.89	32.60	18.46	2.09	30.89	17.83	2.31	29.07	17.17	2.56	27.08	16.46	2.84	24.92	15.69	3.16							
67	31.09	23.87	1.86	29.63	23.28	2.06	28.08	22.65	2.29	26.42	21.98	2.54	24.61	21.25	2.82	22.65	20.44	3.14							
63	28.85	22.88	1.84	27.49	22.29	2.04	26.06	21.67	2.27	24.53	21.00	2.52	22.84	20.27	2.80	21.02	19.45	3.13							
62	28.42	28.42	1.84	27.32	27.32	2.04	26.16	26.16	2.27	24.90	24.90	2.52	23.50	23.50	2.81	21.95	21.95	3.14							
57	28.35	28.35	1.84	27.29	27.29	2.04	26.13	26.13	2.27	24.87	24.87	2.52	23.48	23.48	2.81	21.92	21.92	3.14							
72	34.92	20.44	1.95	33.22	19.83	2.15	31.43	19.19	2.37	29.51	18.51	2.62	27.44	17.78	2.90	25.20	17.00	3.21							
67	31.75	26.10	1.92	30.21	25.48	2.12	28.60	24.82	2.34	26.87	24.11	2.59	25.00	23.32	2.86	23.01	22.41	3.20							
63	29.48	24.95	1.90	28.06	24.33	2.10	26.57	23.87	2.32	24.97	22.96	2.57	23.25	22.15	2.86	21.40	21.19	3.18							
62	29.85	29.85	1.91	28.67	28.67	2.11	27.41	27.41	2.33	26.03	26.03	2.59	24.50	24.50	2.87	22.82	22.82	3.19							
57	29.82	29.82	1.91	28.64	28.64	2.11	27.38	27.38	2.33	26.00	26.00	2.59	24.48	24.48	2.87	22.80	22.80	3.19							

COOLING PERFORMANCE DATA - COOLING ONLY UNITS (CONT)

SIZE	INDOOR UNIT		OUTDOOR UNIT		CONDENSER ENTERING AIR TEMPERATURES deg F																	
					EVAPORATOR AIR		75		85		95		105		115		125					
							CFM	EWB	Capacity MBtu/h†	Total System KW**	Capacity MBtu/h†	Total System KW**	Capacity MBtu/h†	Total System KW**	Capacity MBtu/h†	Total System KW**	Capacity MBtu/h†	Total System KW**	Capacity MBtu/h†	Total System KW**		
34	40MKCB34F--3	24AHA436A00x 124Ax5036000	975	72	38.57	20.08	2.15	36.82	19.40	2.38	34.94	18.67	2.64	32.90	17.90	2.93	30.68	17.07	3.25	28.28	16.18	3.62
				67	35.06	24.40	2.13	33.47	23.71	2.36	31.77	22.99	2.62	29.92	22.22	2.90	27.91	21.39	3.23	25.73	20.50	3.61
				63	32.51	23.50	2.11	31.05	22.82	2.34	29.47	22.10	2.60	27.76	21.34	2.89	25.91	20.51	3.22	23.89	19.63	3.60
				62	31.86	28.62	2.11	30.43	27.92	2.34	28.90	27.16	2.60	27.26	26.33	2.88	25.47	25.47	3.21	23.82	23.82	3.59
				57	30.45	30.45	2.10	29.35	29.35	2.34	28.16	28.16	2.59	26.85	26.85	2.88	25.40	25.40	3.21	23.79	23.79	3.59
				72	39.58	21.28	2.20	37.72	20.56	2.43	35.73	19.81	2.69	33.58	19.01	2.97	31.23	18.16	3.30	28.73	17.25	3.67
				67	36.01	26.24	2.17	34.31	25.54	2.41	32.51	24.79	2.66	30.56	24.00	2.95	28.43	23.14	3.28	26.16	22.22	3.65
				63	33.41	25.22	2.16	31.85	24.52	2.39	30.18	23.78	2.64	28.37	22.99	2.93	26.41	22.14	3.26	24.30	21.22	3.64
				62	32.81	31.05	2.16	31.32	30.28	2.39	29.74	29.40	2.64	28.18	28.18	2.93	26.59	26.59	3.26	24.85	24.85	3.64
				57	32.09	32.09	2.15	30.88	30.88	2.38	29.57	29.57	2.64	28.14	28.14	2.93	26.56	26.56	3.26	24.82	24.82	3.64
				72	40.56	22.74	2.26	38.58	22.01	2.49	36.47	21.24	2.75	34.21	20.43	3.03	31.74	19.54	3.36	29.12	18.62	3.73
				67	36.91	28.59	2.23	35.12	27.86	2.47	33.20	27.09	2.72	31.15	26.26	3.01	28.93	25.36	3.33	26.57	24.38	3.71
63	34.28	27.41	2.22	32.61	26.68	2.45	30.84	25.91	2.70	28.95	25.09	2.99	26.90	24.19	3.32	24.73	23.20	3.69				
62	33.93	33.93	2.21	32.58	32.58	2.45	31.14	31.14	2.71	29.56	29.56	3.00	27.82	27.82	3.33	25.92	25.92	3.70				
57	33.88	33.88	2.21	32.54	32.54	2.45	31.10	31.10	2.71	29.53	29.53	3.00	27.79	27.79	3.33	25.89	25.89	3.70				
72	62.74	32.88	3.71	60.01	31.83	4.08	57.07	30.70	4.52	53.87	29.50	5.02	50.33	28.19	5.59	46.46	26.77	6.24				
67	57.20	40.15	3.66	54.76	39.11	4.04	52.10	38.00	4.47	49.19	36.79	4.97	45.97	35.47	5.54	42.43	34.04	6.20				
63	53.18	38.72	3.63	50.93	37.69	4.00	48.49	36.59	4.43	45.81	35.39	4.93	42.83	34.08	5.50	39.56	32.66	6.16				
62	52.18	47.28	3.62	49.99	46.22	4.00	47.64	45.08	4.43	45.06	43.80	4.92	42.28	42.28	5.50	39.62	39.62	6.16				
57	50.23	50.23	3.61	48.53	48.53	3.98	46.65	46.65	4.42	44.56	44.56	4.92	42.21	42.21	5.50	39.56	39.56	6.16				
72	63.45	33.74	3.74	60.65	32.67	4.12	57.65	31.54	4.55	54.35	30.32	5.05	50.73	28.99	5.62	46.78	27.56	6.28				
67	57.89	41.51	3.70	55.36	40.45	4.07	52.63	39.32	4.50	49.65	38.10	5.00	46.35	36.76	5.58	42.75	35.31	6.23				
63	53.84	39.99	3.66	51.51	38.94	4.04	49.01	37.82	4.47	46.25	36.61	4.96	43.21	35.28	5.54	39.88	33.83	6.19				
62	52.87	49.09	3.66	50.64	48.00	4.03	48.23	46.80	4.46	45.66	45.40	4.96	43.11	43.11	5.54	40.36	40.36	6.20				
57	51.43	51.43	3.65	49.64	49.64	4.02	47.68	47.68	4.46	45.51	45.51	4.96	43.05	43.05	5.54	40.31	40.31	6.20				
72	63.94	34.39	3.77	61.10	33.32	4.14	58.03	32.18	4.58	54.68	30.94	5.08	51.01	29.61	5.65	47.00	28.17	6.30				
67	58.35	42.55	3.72	55.77	41.48	4.10	53.00	40.34	4.53	49.96	39.10	5.03	46.61	37.75	5.60	42.97	36.29	6.25				
63	54.28	40.96	3.69	51.92	39.90	4.06	49.36	38.77	4.49	46.56	37.54	4.99	43.48	36.20	5.56	40.09	34.74	6.21				
62	53.38	50.47	3.68	51.11	49.34	4.06	48.70	48.07	4.49	46.24	46.24	4.99	43.72	43.72	5.57	40.89	40.89	6.23				
57	52.28	52.28	3.67	50.45	50.45	4.05	48.42	48.42	4.49	46.18	46.18	4.99	43.66	43.66	5.57	40.84	40.84	6.23				

† Total and sensible capacities are net capacities. Blower motor heat has been subtracted.

‡ Sensible capacities shown are based on 80°F (27°C) entering air at the indoor coil. For sensible capacities at other than 80°F (27°C), deduct 835 Btu/h (245 kW) per 1000 CFM (480 L/S) of indoor coil air for each degree below 80°F (27°C), or add 835 Btu/h (245 kW) per 1000 CFM (480 L/S) of indoor coil air per degree above 80°F (27°C).

** System kw is total of indoor and outdoor unit kilowatts.

NOTES:

1. Detailed cooling capacities are based on indoor and outdoor unit at the same elevation per AHRI standard 210/240-2008. If additional tubing length and/or indoor unit is located above outdoor unit, a slight variation in capacity may occur.
2. When the required data falls between the published data, interpolation may be performed. Extrapolation is not an acceptable practice.

COOLING PERFORMANCE DATA - HEAT PUMP UNITS

Table 9 – Cooling Performance Data – Heat Pump Units

SIZE	INDOOR UNIT	OUTDOOR UNIT	CONDENSER ENTERING AIR TEMPERATURES deg F																				
			75			85			95			105			115			125					
			CFM	EWB	Capacity MBtu/h†	Total System KW**	Capacity MBtu/h†	Total System KW**	Capacity MBtu/h†	Total System KW**	Capacity MBtu/h†	Total System KW**	Capacity MBtu/h†	Total System KW**	Capacity MBtu/h†	Total System KW**	Capacity MBtu/h†	Total System KW**	Capacity MBtu/h†	Total System KW**			
30	40MKQB36F--3	25HHA430A003 224ANS030000	1310	72	35.19	20.55	33.44	19.93	2.24	29.76	18.64	2.73	27.75	17.94	3.02	25.59	17.20	3.35	3.36				
				67	31.91	26.58	2.05	30.32	25.94	2.25	28.67	25.29	2.48	26.96	24.83	2.74	25.13	23.83		3.03	23.20	22.93	
				63	29.57	25.36	2.06	28.09	24.71	2.26	26.56	24.06	2.48	24.96	23.34	2.74	23.24	22.54		3.03	21.48	21.45	3.36
				62	30.15	30.15	2.05	28.91	28.91	2.26	27.62	27.62	2.48	26.23	26.23	2.74	24.73	24.73		3.03	23.09	23.09	3.36
				57	30.11	30.11	2.05	28.88	28.88	2.26	27.58	27.58	2.48	26.20	26.20	2.74	24.70	24.70		3.03	23.06	23.06	3.36
				72	35.42	21.18	2.06	33.64	20.55	2.27	31.81	19.91	2.49	29.90	19.25	2.75	27.87	18.54		3.04	25.68	17.80	3.37
			1400	1470	67	32.14	27.60	2.07	30.53	26.95	2.28	28.86	26.28	2.51	27.13	25.56	2.76	25.30	24.74	3.05	23.47	23.47	3.38
					63	29.79	26.30	2.08	28.30	25.64	2.28	26.76	24.21	2.77	23.49	23.12	3.06	21.77	21.77	3.38	20.44	20.44	3.38
					62	30.71	30.71	2.08	29.43	29.43	2.28	28.09	28.09	2.51	26.66	26.66	2.76	25.12	25.12	3.05	23.44	23.44	3.38
					57	30.67	30.67	2.08	29.39	29.39	2.28	28.05	28.05	2.51	26.63	26.63	2.76	25.09	25.09	3.05	23.41	23.41	3.38
					72	35.58	21.66	2.08	33.77	21.03	2.27	31.93	20.39	2.51	29.99	19.72	2.77	27.94	19.01	3.06	25.74	18.26	3.39
					67	32.30	28.38	2.09	30.67	27.72	2.29	29.00	27.03	2.52	27.26	26.28	2.78	25.44	25.36	3.07	23.71	23.71	3.40
36	40MKQB36F--3	25HHA436A00x 224AXS036000	1310	63	29.95	27.01	2.10	28.44	26.34	2.30	26.89	25.64	2.53	25.27	24.84	2.78	23.65	23.65	3.07	21.99	21.99	3.40	
				62	31.10	31.10	2.09	29.80	29.80	2.30	28.42	28.42	2.52	26.97	26.97	2.78	25.39	25.39	3.07	23.68	23.68	3.40	
				57	31.06	31.06	2.09	29.76	29.76	2.30	28.39	28.39	2.52	26.94	26.94	2.78	25.36	25.36	3.07	23.66	23.66	3.40	
				72	41.36	22.78	2.53	39.34	22.04	2.80	37.23	21.27	3.09	35.00	20.48	3.42	32.65	19.64	3.80	30.16	18.77	4.22	
				67	37.53	28.84	2.50	35.69	28.10	2.77	33.76	27.33	3.06	31.73	26.51	3.39	29.59	25.65	3.77	27.32	24.74	4.20	
				63	34.79	27.62	2.49	33.08	26.87	2.75	31.29	26.09	3.04	29.40	25.28	3.37	27.39	24.41	3.75	25.27	23.48	4.18	
			1400	1470	62	34.41	34.41	2.49	33.03	33.03	2.75	31.57	31.57	3.04	30.01	30.01	3.38	28.33	28.33	3.76	26.52	26.52	4.19
					57	34.36	34.36	2.49	32.98	32.98	2.75	31.52	31.52	3.04	29.97	29.97	3.37	28.30	28.30	3.76	26.49	26.49	4.19
					72	41.71	23.42	2.56	39.65	22.68	2.82	37.49	21.91	3.12	35.23	21.70	3.45	32.84	20.26	3.83	30.30	19.38	4.25
					67	37.86	29.90	2.53	35.99	29.14	2.80	34.02	28.37	3.09	31.96	27.53	3.42	29.78	26.66	3.79	27.49	25.71	4.22
					63	35.11	28.60	2.52	33.37	27.84	2.78	31.53	27.06	3.07	29.62	26.22	3.40	27.59	25.33	3.77	25.45	24.36	4.21
					62	35.11	35.11	2.52	33.69	33.69	2.78	32.18	32.18	3.07	30.56	30.56	3.41	28.83	28.83	3.79	26.96	26.96	4.22
48	40MKQB48F--3	25HHA448A00x 224AXS048000	1310	57	35.06	35.06	2.51	33.64	33.64	2.78	32.13	32.13	3.07	30.53	30.53	3.41	28.80	28.80	3.79	26.93	26.93	4.22	
				72	41.95	23.92	2.58	39.86	23.17	2.85	37.67	22.39	3.14	35.38	21.58	3.47	32.96	20.74	3.85	30.40	19.85	4.27	
				67	38.09	30.71	2.55	36.19	29.95	2.82	34.20	29.17	3.11	32.12	28.31	3.44	29.93	27.43	3.82	27.62	26.44	4.24	
				63	35.33	29.35	2.54	33.56	28.59	2.80	31.71	27.80	3.09	29.78	26.94	3.42	27.73	26.03	3.80	25.59	25.01	4.23	
				62	35.63	35.63	2.54	34.16	34.16	2.80	32.61	32.61	3.10	30.96	30.96	3.43	29.19	29.19	3.81	27.27	27.27	4.24	
				57	35.58	35.58	2.54	34.11	34.11	2.80	32.57	32.57	3.10	30.92	30.92	3.43	29.15	29.15	3.81	27.24	27.24	4.24	
			1400	1470	72	55.55	28.41	3.21	52.84	27.36	3.57	49.98	26.26	3.96	46.97	25.13	4.39	43.77	23.93	4.87	40.40	22.70	5.41
					67	50.64	34.79	3.19	48.20	33.75	3.53	45.61	32.65	3.92	42.85	31.50	4.35	39.93	30.30	4.83	36.81	29.04	5.38
					63	47.04	33.56	3.17	44.81	32.53	3.51	42.42	31.44	3.89	39.87	30.30	4.31	37.14	29.09	4.80	34.24	27.82	5.35
					62	46.13	41.04	3.17	43.95	39.98	3.50	41.64	38.87	3.88	39.18	37.66	4.31	36.80	36.30	4.79	34.16	34.16	5.35
					57	44.09	44.09	3.16	42.39	42.39	3.49	40.58	40.58	3.87	38.60	38.60	4.30	36.44	36.44	4.79	34.11	34.11	5.35
					72	56.20	29.13	3.24	53.41	28.06	3.60	50.48	26.95	3.98	47.40	25.80	4.42	44.13	24.59	4.90	40.70	23.35	5.44
1400	1470	67	51.25	35.94	3.21	48.75	34.88	3.56	46.07	33.76	3.94	43.26	32.60	4.37	40.26	31.39	4.86	37.10	30.12	5.40			
		63	47.64	34.64	3.20	45.34	33.58	3.54	42.88	32.48	3.91	40.27	31.32	4.34	37.47	30.10	4.83	34.52	28.82	5.38			
		62	46.74	42.60	3.19	44.51	41.51	3.53	42.15	40.36	3.91	39.67	39.08	4.34	37.23	37.23	4.83	34.81	34.81	5.38			
		57	45.14	45.14	3.18	43.38	43.38	3.52	41.48	41.48	3.90	39.41	39.41	4.33	37.18	37.18	4.82	34.77	34.77	5.38			
		72	56.65	29.67	3.26	53.80	28.59	3.62	50.83	27.48	4.01	47.69	26.31	4.44	44.37	25.10	4.92	40.89	23.84	5.46			
		67	51.69	36.82	3.23	49.11	35.74	3.58	46.40	34.62	3.97	43.54	33.45	4.39	40.49	32.22	4.88	37.30	30.94	5.42			
63	48.06	35.46	3.22	45.70	34.39	3.56	43.20	33.28	3.94	40.54	32.11	4.36	37.70	30.88	4.85	34.72	29.58	5.40					
62	47.19	43.78	3.21	44.93	42.68	3.55	42.54	41.47	3.93	40.07	40.07	4.36	37.76	37.76	4.85	35.28	35.28	5.40					
57	45.91	45.91	3.21	44.09	44.09	3.55	42.13	42.13	3.93	40.01	40.01	4.36	37.71	37.71	4.85	35.23	35.23	5.40					

† Total and sensible capacities are net capacities. Blower motor heat has been subtracted.

‡ Sensible capacities shown are based on 80°F (27°C) entering air at the indoor coil. For sensible capacities at other than 80°F (27°C), deduct 835 Btu/h (245 kW) per 1000 CFM (480 L/S) of indoor coil air for each degree below 80°F (27°C), or add 835 Btu/h (245 kW) per 1000 CFM (480 L/S) of indoor coil air per degree above 80°F (27°C).

** System kw is total of indoor and outdoor unit kilowatts.

EWB — Entering Wet Bulb

NOTES:

1. Detailed cooling capacities are based on indoor and outdoor unit at the same elevation per AHRI standard 210/240 – 2008. If additional tubing length and/or indoor unit is located above outdoor unit, a slight variation in capacity may occur.
2. When the required data falls between the published data, interpolation may be performed. Extrapolation is not an acceptable practice.

HEATING PERFORMANCE DATA - HEAT PUMP UNITS

Table 10 – Heating Performance Data - Heat Pump Units

SIZE	INDOOR UNIT	OUTDOOR UNIT	OUTDOOR COIL ENTERING AIR TEMPERATURES deg F																						
			INDOOR AIR			17			27			37			47			57			67				
			EDB	CFM	Total System KW†	Capacity MBtuh	Total System KW†	Capacity MBtuh	Total System KW†	Capacity MBtuh	Total System KW†	Capacity MBtuh	Total System KW†	Capacity MBtuh	Total System KW†	Capacity MBtuh	Total System KW†	Capacity MBtuh	Total System KW†	Capacity MBtuh	Total System KW†	Capacity MBtuh	Total System KW†		
30	40MIKQB36F-3	25HHA430A003 224A1NS030000	65	1310	14.97	1.82	20.90	18.56	1.89	24.80	22.57	1.94	29.15	29.15	1.98	34.27	34.27	2.04	40.12	40.12	2.11	46.81	46.81		
				1400	16.57	1.84	21.04	18.69	1.90	24.97	22.72	1.94	29.34	29.34	1.99	34.51	34.51	2.04	40.41	40.41	2.10	46.81	46.81		
				1470	16.67	1.85	21.15	18.78	1.91	25.08	22.82	1.95	29.49	29.49	1.99	34.69	34.69	2.04	40.61	40.61	2.10	46.81	46.81		
				1310	15.91	1.90	19.96	17.73	1.96	24.39	22.19	2.02	28.68	28.68	2.07	33.66	33.66	2.12	39.41	39.41	2.19	46.81	46.81		
				1400	16.05	1.91	20.16	17.91	1.97	24.55	22.34	2.02	28.87	28.87	2.07	33.90	33.90	2.12	39.69	39.69	2.19	46.81	46.81		
				1470	16.16	1.92	20.31	18.04	1.98	24.66	22.44	2.03	29.00	29.00	2.07	34.07	34.07	2.12	39.90	39.90	2.19	46.81	46.81		
	70	40MIKQB36F-3	25HHA430A003 224A1NS030000	75	1310	15.37	1.98	19.36	17.19	2.04	24.00	21.84	2.10	28.21	28.21	2.16	33.07	33.07	2.21	38.71	38.71	2.28	46.81	46.81	
					1400	15.51	1.99	19.52	17.34	2.05	24.15	21.97	2.11	28.39	28.39	2.16	33.31	33.31	2.21	38.99	38.99	2.28	46.81	46.81	
					1470	15.62	2.00	19.65	17.45	2.05	24.25	22.06	2.11	28.53	28.53	2.16	33.47	33.47	2.21	39.19	39.19	2.28	46.81	46.81	
					1310	19.33	17.63	2.15	23.84	21.17	2.21	29.39	26.74	2.29	34.35	34.35	2.36	40.13	40.13	2.45	46.81	46.81	2.57	46.81	46.81
					1400	19.51	17.79	2.15	24.04	21.35	2.21	29.58	26.92	2.29	34.60	34.60	2.35	40.44	40.44	2.44	47.23	47.23	2.55	46.81	46.81
					1470	19.64	17.91	2.16	24.19	21.48	2.22	29.74	27.06	2.29	34.77	34.77	2.35	40.67	40.67	2.43	47.52	47.52	2.54	46.81	46.81
36	40MIKQB36F-3	25HHA436A00x 224A1NS036000	70	1310	18.69	17.04	2.24	23.16	20.57	2.30	28.88	26.28	2.40	33.79	33.79	2.47	39.42	39.42	2.56	45.98	45.98	2.68	46.81	46.81	
				1400	18.87	17.20	2.25	23.36	20.75	2.31	29.08	26.46	2.39	34.03	34.03	2.46	39.73	39.73	2.54	46.38	46.38	2.66	46.81	46.81	
				1470	19.00	17.32	2.25	23.51	20.88	2.31	29.23	26.60	2.39	34.20	34.20	2.46	39.95	39.95	2.54	46.67	46.67	2.64	46.81	46.81	
				1310	17.99	16.41	2.33	22.46	19.95	2.40	27.59	25.11	2.49	33.22	33.22	2.58	38.72	38.72	2.67	45.15	45.15	2.80	46.81	46.81	
				1400	18.17	16.57	2.34	22.67	20.13	2.41	27.91	25.39	2.49	33.44	33.44	2.57	39.03	39.03	2.66	45.55	45.55	2.78	46.81	46.81	
				1470	18.30	16.69	2.35	22.82	20.27	2.41	28.16	25.63	2.49	33.61	33.61	2.57	39.25	39.25	2.65	45.82	45.82	2.76	46.81	46.81	
	48	40MIKQB48F-3	25HHA448A00x 224A1NS048000	65	1310	24.13	3.02	32.32	28.70	3.15	39.75	36.17	3.33	46.52	46.52	3.49	53.91	53.91	3.67	62.41	62.41	3.90	63.03	63.03	
					1400	26.71	24.36	3.02	32.62	28.97	3.14	40.40	36.77	3.31	46.88	46.88	3.45	54.39	54.39	3.62	63.03	63.03	3.83	63.03	63.03
					1470	26.89	24.51	3.02	32.83	29.16	3.13	40.63	36.97	3.30	47.13	47.13	3.43	54.73	54.73	3.59	63.48	63.48	3.79	63.48	63.48
					1310	25.69	23.42	3.13	31.47	27.95	3.27	38.21	34.77	3.44	45.83	45.83	3.64	53.06	53.06	3.83	61.41	61.41	4.07	61.41	61.41
					1400	25.93	23.64	3.13	31.77	28.22	3.26	38.71	35.22	3.42	46.17	46.17	3.60	53.52	53.52	3.78	62.01	62.01	4.00	62.01	62.01
					1470	26.11	23.80	3.13	31.99	28.41	3.26	39.08	35.57	3.41	46.40	46.40	3.58	53.85	53.85	3.75	62.44	62.44	3.95	62.44	62.44
48	40MIKQB48F-3	25HHA448A00x 224A1NS048000	75	1310	24.85	3.26	30.61	27.18	3.41	37.15	33.80	3.58	45.14	45.14	3.80	52.24	52.24	4.00	60.43	60.43	4.24	60.43	60.43		
				1400	25.10	3.26	30.90	27.45	3.39	37.53	34.15	3.55	45.44	45.44	3.76	52.68	52.68	3.94	61.01	61.01	4.18	61.01	61.01		
				1470	25.29	3.26	31.11	27.63	3.39	37.81	34.41	3.54	45.69	45.69	3.74	53.00	53.00	3.91	61.43	61.43	4.13	61.43	61.43		

** The Btuh heating capacity values shown are net integrated values from which the defrost effect has been subtracted. The Btuh heating from supplement heaters should be added to those values to obtain total system capacity.
 † The kW values include the compressor, outdoor fan motor, and indoor blower motor. The kW from supplement heaters should be added to these values to obtain total system kilowatts.
 NOTE: When the required data falls between the published data, interpolation may be performed. Extrapolation is not an acceptable practice.
 EDB — Entering Dry Bulb"

APPLICATION DATA

UNIT SELECTION

The horizontal units are available as cooling only and heat pumps. For most applications, the cooling load dictates the size selection. Select equipment to either match or be slightly less than anticipated peak load. This provides better humidity control, fewer unit cycles, and better low load performance.

For units used in spaces with high sensible loads, base equipment selection on unit sensible load, not on total anticipated load to avoid oversizing the equipment.

UNIT MOUNTING (INDOOR)

Unit leveling - For reliable operation, units should be level in all planes.

Clearance - Provide adequate clearance for airflow (see Fig. 7).

Unit location - Select a location which will provide the best air circulation for the room.

The Under Ceiling units should be mounted near the ceiling and against a wall. The unit should be centered in the room for best performance. Locating the unit on an outside wall makes piping easier, however units can also be mounted away from a wall if desired. If unit is mounted away from a wall, the rear panel of the unit may need a field-supplied trim strip for improved appearance. Locate the fan coil return over an area which is not normally occupied for quietest operation. Do not block air discharge for a minimum of 15 ft (4.6 m) to prevent dumping of cold air and drafts.

Support - The structure must provide adequate support for the weight of the fan coil. Refer to the Physical Data section for fan coil weights.

Mounting Template - The fan coil units are furnished with cardboard mounting templates to mark the hole locations for wiring and refrigerant lines.

UNIT MOUNTING (OUTDOOR)

Unit leveling - For reliable operation, units should be level in all planes.

Clearance - Minimum clearance, as shown in Fig. 10, must be provided for airflow. The condensing units are designed for free-blow application. Air inlets and outlets should not be restricted.

Unit location - A location which is convenient to installation and not exposed to strong wind. If the unit is exposed to strong winds it is recommended that a wind baffle accessory be used.

A location which can bear the weight of outdoor unit and where the outdoor unit can be mounted in a level position.

SYSTEMS OPERATING CONDITIONS

Table 11—Cooling Operating Range

	Maximum		Minimum	
	DB °F (°C)	WB °F (°C)	DB °F (°C)	WB °F (°C)
Outdoor Unit	125 (51.7)	--	55 (12.8)	--
Indoor Unit	90 (32.2)	84 (29)	64 (18)	59 (29)

Table 12—Heating Operating Range

	Maximum		Minimum	
	DB °F (°C)	WB °F (°C)	DB °F (°C)	WB °F (°C)
Outdoor Unit	75 (23.9)	67 (19.4)	17 (-8.3)	--
Indoor Unit	80 (27)	--	32 (0)	--

Low Ambient Operation

Both the cooling only and heat pumps operate to cool down to 55°F (12.8°C). When equipped with a Low Ambient Controller, the unit operates down to -20°F (-28.9°C).

For proper operation of cooling only units, a Winter Start Kit), a Crankcase Heater (prevents refrigerant migration during compressor-off cycle), and a Wind Baffle should also be installed.

On heat pumps, a Winter Start Kit will not be required. An Isolation Relay, to bypass the Low Ambient Controller when unit is in heating mode, is required.

Metering Devices

The metering device(s) for these systems is a type B accurater. The cooling accurater is installed with the indoor unit, while the heating accurater is installed with the outdoor unit. One Accurater is required for the cooling only system and two are required for the heat pump systems. Refer to Table 13 for the accurater size.

Table 13—Metering Device

System Size kBTU/hr	Cooling Only	Heat Pumps	
	40MKCB**C	40MKQB**C	25HHA4/224ANS
018	TXV	-	-
024	TXV	-	-
030	TXV	TXV	0.055"
034	TXV	-	-
054	TXV	-	-
036	-	TXV	0.063"
048	-	TXV	0.073"

DRAIN CONNECTIONS

When the unit is installed close to an outside wall, a downward sloped condensate line can be used to dispose of the water (do not trap condensate line). If this is not feasible, an accessory condensate pump that can be installed inside the unit is available.

When using a condensate pump, the drain pipe can be routed through the top of the unit, if desired.

Install drains to meet local sanitation codes. If adequate gravity drainage cannot be provided, unit should be equipped with accessory condensate pump.

REFRIGERANT LINES

General refrigerant line sizing:

1. Refrigerant lines can access the Under Ceiling unit from either the top-right or rear-right when facing the unit.
2. Refrigerant lines should not be buried in the ground. If it is necessary to bury the lines, not more than 36-in (914 mm) should be buried. Provide a minimum 6-in (152 mm) vertical rise to the service valves to prevent refrigerant migration.
3. Both lines must be insulated. Use a minimum of 1/2-in. (12.7mm) thick insulation. Closed-cell insulation is recommended in all long-line applications.
4. Special consideration should be given to isolating interconnecting tubing from the building structure. Isolate the tubing so that vibration or noise is not transmitted into the structure.

NOTE: Since the same outdoor unit can be matched with different types of indoor units, it may not have enough refrigerant charge. Refer to the Physical Data tables to determine if additional charge is required.

Long Line Applications

The minimum length between the indoor and outdoor units is 10 ft. (3m). Refer to the following table for the maximum lengths allowed.

Table 14—Long Line Applications

Outdoor Unit Size	Max Equivalent Length* ft (m)	Max Elevation (ID over OD) ft (m)	Max Elevation (OD over ID) ft (m)
18-54K	250 (76.2)	65 (19.8)	200 (61)

NOTE: For lengths greater than 25 ft (7.6 m), refer to the *Residential Long Line* guide.

* Maximum actual length not to exceed 200 ft (61 m)
Total equivalent length accounts for losses due to elbows or fitting.
See the Long Line Guideline for details.

CONTROL SYSTEM

The ductless unit is equipped with a microprocessor controls to operate the system and provide optimum levels of comfort and operating efficiency.

The main microprocessor is located in the control box of the fan coil unit with thermistors located in the fan coil inlet and on the indoor coil. These thermistors monitor the system operation and control the operating mode. To change the settings or the modes of operation, use the factory supplied wireless remote control or accessory wired controller.

The ductless unit has 5 operating modes:

- Fan Only
- Auto (heat pump models only)
- Heating (heat pump models only)
- Cooling
- Dehumidification (Dry)

FAN ONLY - In the Fan Only mode, the system filters and circulates the room air without changing the room air temperature.

AUTO - In Auto mode, the system will automatically select one of the following operating modes: cooling, heating or fan only based on the difference between the room temperature and the set point temperature.

HEATING - In the Heating mode, the system heats and filters room air.

COOLING - In the Cooling mode, the system cools, dries and filters room air.

DEHUMIDIFICATION (DRY) - in Dehumidification (Dry) mode, the system dries, filters and slightly cools room temperature. This mode does not take the place of a dehumidifier.

In addition to the above modes that are selected by using the remote control. The unit can run in two other modes selected by the manual button:

- EMERGENCY RUN
- TEST MODE

EMERGENCY mode - is used when the remote control is misplaced or the batteries in the remote control have expired. Pushing the manual button under the front cover will put the unit in Auto mode with a predetermined set point (73.4°F/ 23°C).

TEST mode - is used when a technician needs to diagnose the unit for a malfunction. The unit can be set into TEST mode using the remote control. It will run regardless of the set point.

The microprocessor controls offer additional comfort and economy features like SLEEP mode, TIMER and AUTO SWEEP. Refer to the Owner's Manual for additional details on these features.

USER INTERFACE

The units come standard with a wireless remote control. The wireless remote has a range of 25 ft (8 m) when pointed toward the unit.

For some applications (commercial), a wired remote may be more desirable. A wired remote control is offered as an accessory.

Table 15—Air Throw Data

	Air Throw Data ft (m)
18 (AC)	26 (7.9)
24-54 (AC)	
30-48 (HP)	29 (8.8)

SOUND RATINGS

Outdoor Units

Table 16—A-WEIGHTED SOUND POWER (dBA)

	Outdoor Unit Size	Standard Rating	Typical Octave Band Spectrum (dBA, without tone adjustment)						
		(dBA)	125	250	500	1000	2000	4000	8000
Cooling Only	18	69	50.5	57.0	59.5	64.5	60.5	53.5	43.0
	24	66	50.5	58.5	60.5	59.5	56.5	51.0	41.5
	30	68	55.5	59.5	61.5	63.5	60.0	58.0	49.5
	36	71	59.5	59.5	62.0	65.5	63.5	62.0	55.0
Heat Pump	30	72	58.0	61.0	64.0	66.5	64.0	63.5	57.0
	36	71	59.5	59.5	62.5	65.0	63.0	61.5	55.0
	48	70	57.5	59.5	63.0	65.0	62.5	60.0	54.0

NOTE: Tested in accordance with AHRI Standard 270-08 (not listed in AHRI).

Table 17—Indoor Units

ESTIMATED UNDER CEILING SOUND PRESSURE LEVEL				
Under-ceiling		AC: 18	AC: 24 – 34	AC: 54
				HP: 30 – 48
Cooling operation Indoor Sound Pressure for CO and HP cooling mode (at Different Speeds)	dBa (cfm)	53/48/42 (695/515/405)	55/52/50 (1335/1130/975)	59/57/55 (1470/1400/1310)
Heating operation Indoor Sound Pressure for HP heating mode (at Different Speeds)	dBa (cfm)	NA	NA	58/55/54 (1470/1400/1310)
ESTIMATED UNDER CEILING SOUND POWER LEVEL				
Under-ceiling		AC: 18	AC: 24 – 34	AC: 54
				HP: 30 – 48
Cooling operation Indoor Sound Pressure for CO and HP cooling mode (at Different Speeds)	dBa (cfm)	63/58/52(695/515/405)	65/62/60(1335/1130/975)	69/67/65 (1470/1400/1310)
Heating operation Indoor Sound Pressure for HP heating mode (at Different Speeds)	dBa (cfm)	NA	NA	68/65/64 (1470/1400/1310)

NOTES:

1. Sound power ratings are tested in accordance with AHRI standard 270 -- --95 (not listed in AHRI) and AHRI 350.
2. Sound pressure ratings are estimated sound pressure, 3 feet (.91 m) from the unit, based on sound power data.

WIRING

The indoor and outdoor units have their own power supply. Refer to installation instructions for Wiring instructions.

ELECTRICAL DATA

Table 18—24AHA4/124ANS Electrical Data

UNIT SIZE -- voltage,series	V/PH	OPER VOLTS*		COMPR		FAN	MCA	MAX FUSE** or CKT BRK AMPS
		MAX	MIN	LRA	RLA	FLA		
18--30	208/230/1	253	197	56.3	9	0.5	11.8	20
24--30				62.9	10.9	0.5	14.1	25
30--30				73	14.1	0.7	18.3	30
36--30				77	14.1	1.2	18.8	30
48--30				124	18.5	1.2	24.3	40
36--50	208/230/3	253	197	71	9	1.2	12.5	20
48--50				83.1	13.7	1.2	18.3	30
36--60	460/3	506	414	38	5.6	0.6	7.6	15
48--60				41	6.2	0.6	8.4	15

Table 19—25HHA4/224ANS Electrical Data

UNIT SIZE -- voltage,series	V/PH	OPER VOLTS*		COMPR		FAN	MCA	MAX FUSE** or CKT BRK AMPS
		MAX	MIN	LRA	RLA	FLA		
30--30	208/230/1	253	197	64	12.8	1.2	17.2	30
36--30				77	14.2	1.2	19	30
48--30				117	21.8	1.45	28.8	50
36--50	208/230/3	253	197	71	9.3	1.2	12.8	20
48--50				83.1	13.7	1.45	18.6	30
36--60	460/3	506	414	38	5.6	0.6	7.6	15
48--60				41	6.2	0.8	8.6	15

Table 20—40MKCBF Electrical Data**

Indoor Unit Size BTU/Hr	V-Ph-Hz	Voltage Range		Fan	Power	
		Min (V)	Max (V)	FLA (A)	Min Ckt Amp (A)	Max Fuse CB Amp (A)
18K	208-230-1-60	187	253	0.71	1	15
24K - 34K	208-230-1-60	187	253	0.7 x 2	3	15
54K	208-230-1-60	187	253	0.95 x 2	3	15

Table 21—40MKQBF Electrical Data**

Indoor Unit Size BTU/Hr	V-Ph-Hz	Voltage Range		Fan	Power	
		Min (V)	Max (V)	FLA (A)	Min Ckt Amp (A)	Max Fuse CB Amp (A)
30K- 48K	208-230-1-60	187	253	0.95 x2	3	15

LEGEND

FLA – Full Load Amps

HACR – Heating, Air Conditioning, Refrigeration

LRA – Locked Rotor Amps

NEC – National Electrical Code

RLA – Rated Load Amps (compressor)

*Permissible limits of the voltage range at which the unit will operate satisfactorily

****Time-Delay fuse.**

Complies with 2007 requirements of ASHRAE Standards 90.1

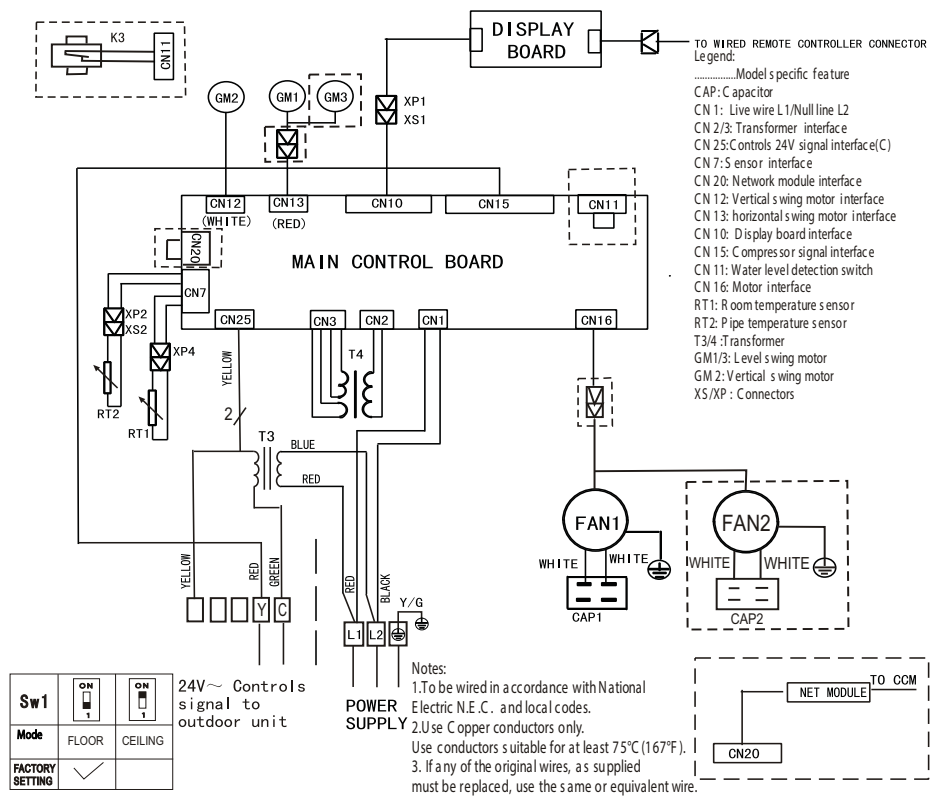

Fig. 9 – 40MKCB**F wiring diagram

OUTDOOR UNIT SCHEMATIC DIAGRAM

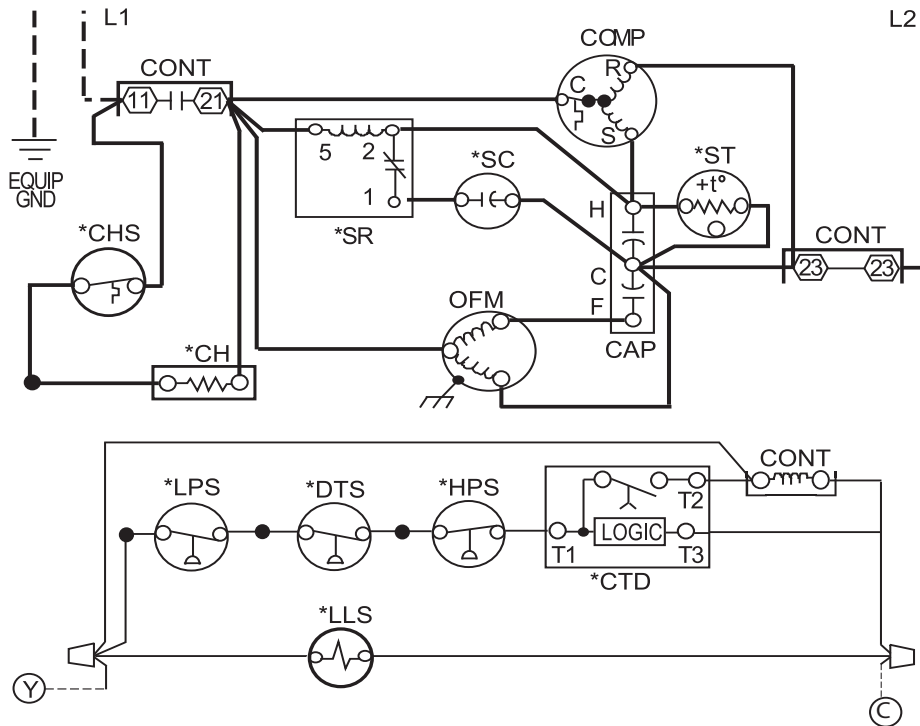

Fig. 10 – 24AHA4/124ANS Wiring Diagram 208/230V 1 Phase

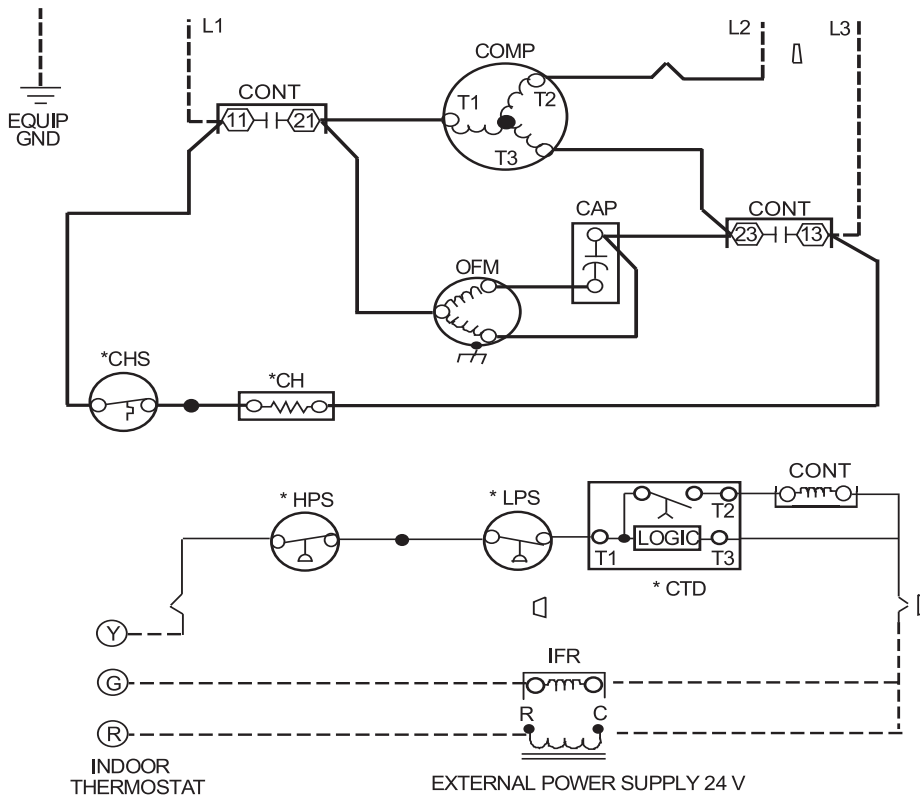

Fig. 11 – 24AHA4/124ANS Wiring Diagram 208/230 - 460V 3 phase

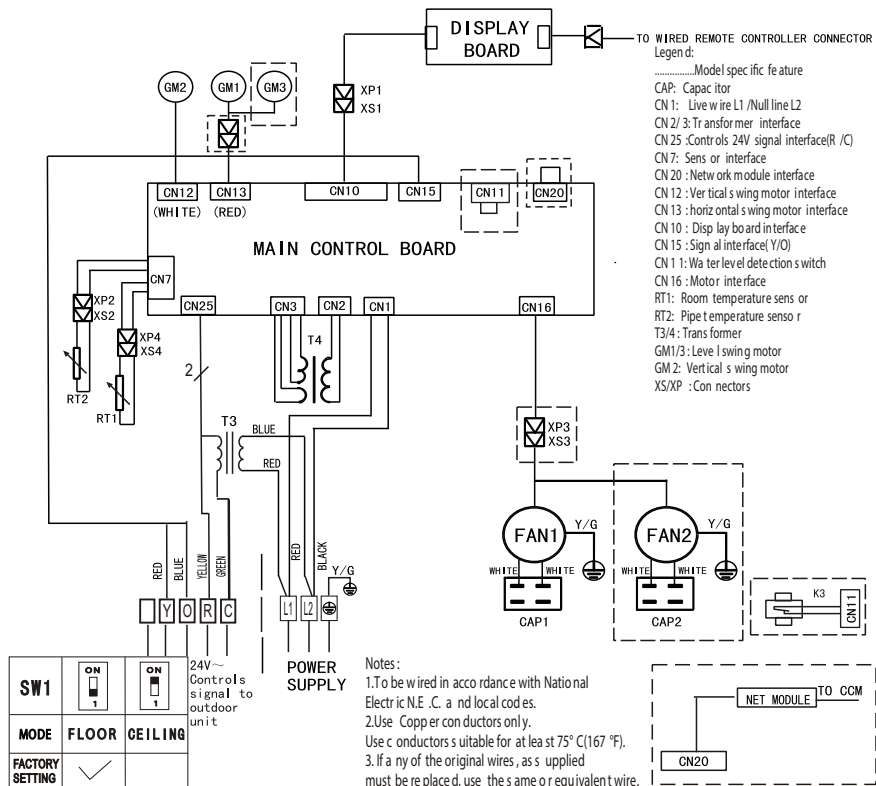

Fig. 12 – 40MKQB**F wiring diagram

GUIDE SPECIFICATIONS

INDOOR UNDER CEILING DUCTLESS UNITS

Model Number: 40MKCF/40MKQF

Size Range: 1-1/2 to 4-1/2 Ton Nominal Cooling and Heating Capacity

PART 1 - GENERAL

1.01 System Description

Indoor, under ceiling, direct-expansion fan coils are matched with cooling only or heat pump outdoor unit.

1.02 Agency Listings

Unit shall be rated per AHRI Standards 210/240 and listed in the AHRI directory as a matched system.

1.03 Delivery, Storage, And Handling

Units shall be stored and handled per unit manufacturer's recommendations.

1.04 Warranty (For Inclusion By Specifying Engineer)

PART 2 - PRODUCTS

2.01 Equipment

A. General:

Indoor, direct-expansion, under ceiling fan coil. Unit shall be complete with cooling/heating (heat pump systems only) coil, fan, fan motor, piping connectors, electrical controls, microprocessor control system, and integral temperature sensing. Unit shall be furnished with mounting bracket.

B. Unit Cabinet:

1. Unit cabinet shall be zinc-coated bonderized steel finished with a baked enamel paint.
2. Inlet grilles shall be attractively styled, high impact polystyrene.
3. Matching mounting brackets shall be provided.

C. Fans:

1. Indoor fans shall be 3-speed centrifugal blower type with air intake in the bottom rear of the unit and discharge in the front.
2. Automatic, motor-driven horizontal air sweep shall be provided standard.

D. Coil:

Coil shall be copper tube with aluminum fins and galvanized steel tube sheets. Fins shall be bonded to the tubes by mechanical expansion and specially coated for enhanced wettability. A drip pan under the coil shall have a drain connection for the hose attachment to remove condensate.

E. Motors:

Motors shall be open drip-proof, permanently lubricated ball bearing with inherent overload protection. Fan motors shall be 3-speed.

F. Controls:

Controls shall consist of a microprocessor-based control system which shall control space temperature, determine optimum fan speed, and run self diagnostics. The temperature control range shall be from 62°F to 86°F (17°C to 30°C) in increments of 1°F or 1°C, and have 46°F Heating Mode (Heating Setback). The wireless remote controller shall have the ability to act as the temperature sensing location for room comfort..

The unit shall have the following functions as a minimum:

1. An automatic restart after power failure at the same operating conditions as at failure.
2. A timer function to provide a minimum 24-hour timer cycle for system Auto Start/Stop.
3. Temperature-sensing controls shall sense return air temperature.
4. Indoor coil freeze protection.
5. Wireless infrared remote control to enter set points and operating conditions.
6. Automatic vertical air sweep control to provide on or off activation of air sweep louvers.
7. Dehumidification mode shall provide increased latent removal capability by modulating system operation and set point temperature.
8. Fan-only operation to provide room air circulation when no cooling is required.
9. Diagnostics shall provide continuous checks of unit operation and warn of possible malfunctions. Error messages shall be displayed at the unit.
10. Fan speed control shall be user-selectable: high, medium, low, or microprocessor controlled automatic operation during all operating modes.
11. Automatic heating-to-cooling changeover in heat pump mode. Control shall include deadband to prevent rapid mode cycling between heating and cooling.
12. Indoor coil high temperature protection shall be provided to detect excessive indoor discharge temperature when unit is in heat pump mode (Heat pump units only).

G. Filters:

Unit shall have filter track with factory-supplied cleanable filters.

H. Electrical Requirements:

Indoor units shall be 208/230-1-60 and require their own power supply. Only control wiring shall run between the indoor and outdoor units.

I. Operating Characteristics:

The 40MK*F when matched with the appropriate outdoor section, shall have a minimum listed SEER (seasonal energy efficiency ratio) of 14 at AHRI conditions, and a minimum HSPF of 8.2 (Heat pump units only).

J. Refrigerant Lines:

All units should have refrigerant lines that can be oriented to connect from the left, right or back of unit. Both refrigerant lines need to be insulated.

K. Special Features (Field Installed):

1. Condensate Pump: - The condensate pump shall remove condensate from the drain pan when gravity drainage cannot be used. Pump shall be designed for quiet operation. Pump shall consist of two parts: an internal reservoir/sensor assembly, and a remote sound-shielded pump assembly. A liquid level sensor in the reservoir shall stop cooling operation if the liquid level in the reservoir is unacceptable.
2. Wired Control (Optional): - The wired control can replace the standard wireless control and provide the User Interface to control one unit.

GUIDE SPECIFICATIONS

HORIZONTAL DISCHARGE OUTDOOR UNITS

Model Number: 24AHA4/25HHA4/124ANS/224ANS

Size Range: 1-1/2 to 4 - 1/2 Ton Nominal Cooling and Heating Capacity

PART 1 - GENERAL

1.01 System Description

- A. Outdoor air-cooled split system compressor sections suitable for on-the-ground, rooftop, wall hung or balcony mounting. Units shall consist of a scroll compressor, an air-cooled coil, propeller-type blow-through outdoor fan, reversing valve (HP), accumulator, Accurator metering device(s), and control box. Units shall discharge air horizontally as shown on the contract drawings. Units shall function as the outdoor component of an air-to-air cooling only, or heat pump system.
- B. Units shall be used in a refrigeration circuit matched to ductless cooling only or heat pump fan coil units.

1.02 Agency Listings

- A. Unit construction shall comply with ANSI/ASHRAE 15, latest revision, and with the NEC.
- B. Units shall be evaluated in accordance with UL standard 1995.
- C. Units shall be listed in the CEC directory.
- D. Unit cabinet shall be capable of withstanding 500-hour salt spray test per Federal Test Standard No. 141 (method 6061).
- E. Air-cooled condenser coils shall be leak tested at 573 psig.

1.03 Delivery, Storage, And Handling

Units shall be shipped in one piece and shall be stored and handled per unit manufacturer's recommendations.

1.04 Warranty (For Inclusion By Specifying Engineer)

PART 2 - PRODUCTS

2.01 Equipment

A. General:

Factory assembled, single piece, air-cooled outdoor unit. Contained within the unit enclosure shall be all factory wiring, piping, controls, and the compressor.

B. Unit Cabinet:

- 1. Unit cabinet shall be constructed of galvanized steel, bonderized and coated with a baked-enamel finish on inside and outside.
- 2. Unit access panels shall be removable with minimal screws and shall provide full access to the compressor, fan, and control components.
- 3. Outdoor compartment shall be isolated and have an acoustic lining to assure quiet operation.
- 4. Compressor compartment shall be isolated to allow performing diagnostics while the system is running.

C. Fans:

- 1. Outdoor fans shall be direct-drive propeller type, and shall discharge air horizontally. Fans shall blow air through the outdoor coil.
- 2. Outdoor fan motors shall be totally enclosed, single phase motors with class B insulation and permanently-lubricated bearings. Motor shall be protected by internal thermal overload protection.
- 3. Shaft shall have inherent corrosion resistance.
- 4. Fan blades shall be metallic and shall be statically and dynamically balanced.
- 5. Outdoor fan openings shall be equipped with PVC coated metal protective grille over fan.

D. Compressor:

- 1. Compressor shall be fully hermetic scroll type.
- 2. Compressor shall be equipped with oil system, operating oil charge, and motor. Internal overloads shall protect the compressor from over-temperature and over-current.
- 3. Motor shall be NEMA rated class F, suitable for operation in a refrigerant atmosphere.
- 4. Compressor assembly shall be installed on rubber vibration isolators.
- 5. Compressors shall be available in single-phase (sizes 018-036) and three-phase (size 036).

E. Outdoor Coil:

Coil shall be constructed of aluminum fins mechanically bonded to seamless copper tubes, which are cleaned, dehydrated, and sealed.

F. Refrigeration Components:

Refrigerant circuit components shall include brass external liquid line service valve with service gage port connections, suction line service valve with service gage connection port, service gage port connections on compressor suction and discharge lines with Schrader type fittings with brass caps, accumulator, reversing valve.

G. Controls and Safeties:

Operating controls and safeties shall be factory selected, assembled, and tested. The minimum control functions shall include:

- 1. Controls:
 - a. A time delay control sequence is provided standard through the fan coil board.
 - b. Automatic outdoor-fan motor protection.
- 2. Safeties:
 - a. Diagnostics provided by matched indoor unit.
 - b. Compressor motor current and temperature overload protection.
 - c. Outdoor fan failure protection (High Pressure Switch).
 - d. Low pressure protection.
 - e. Fusible plug to vent refrigerant safely in case of a fire.

H. Electrical Requirements:

- 1. All sizes shall operate on single-phase, 60 Hz power at 208/230V or on three-phase, 60 Hz power at either 208/230 or 460 (for 36 & 48 size units).
- 2. Unit control voltage to the indoor-fan coil shall be 24 VDC.
- 3. All power and control wiring must be installed per NEC and all local electrical codes.

I. Refrigerant Line Lengths:

- 1. The unit shall be capable of 200 ft (61 m) maximum piping, a maximum lift (fan coil above) of 65 ft (19.8 m) and a maximum drop (fan coil below) of 150 ft (45.8 m). Accessories will be required to achieve these lengths.

J. Special Features (Field Installed):

- 1. Low-Ambient Kit: Control shall regulate fan-motor cycles in response to saturated condensing temperature of the unit. The control shall be capable of maintaining a condensing temperature of 100°F ± 10°F (37.78°C ± 5.5°C) with outdoor temperatures to -20°F (-28.9°C). Installation of kit shall not require changing the outdoor fan motor.
- 2. Crankcase Heater
- 3. Wind baffle
- 4. Stacking Kit
- 5. Wall Mounting Kit

