

**58STA/STX
4-WAY MULTIPOISE INDUCED-COMBUSTION
GAS FURNACE**
Input Capacities: 45,000 thru 155,000 Btuh

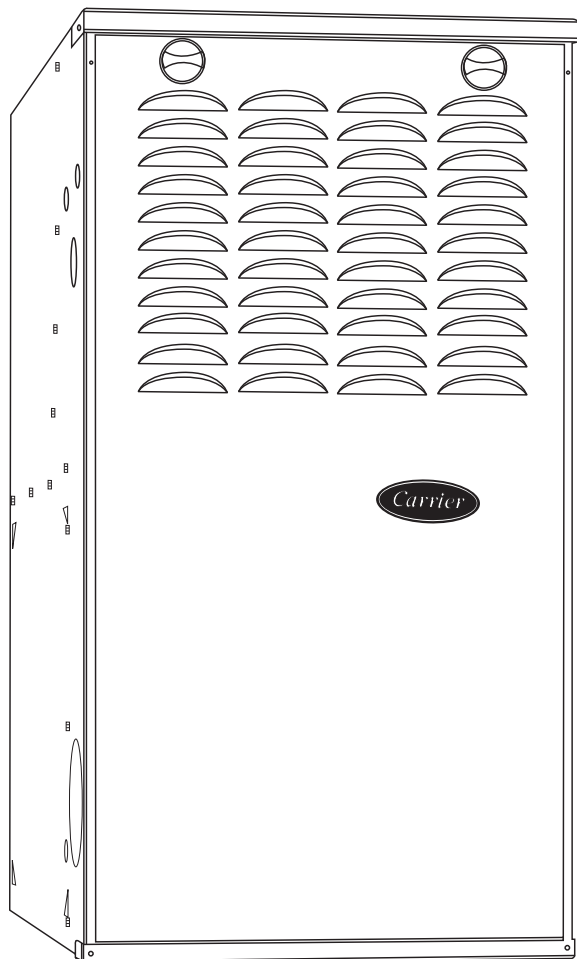

Product Data



A10247

THE CARRIER 58STA/STX GAS FURNACE

The 58STA/STX 4-way Multipoise Gas Furnaces feature Carrier's QuieTech™ noise reduction system for incredibly quiet induced draft operation. Applications are easy with 4-way multipoise design, through-the-furnace downflow venting, 13 different venting options, and designed for easy service access. An inner blower door is provided for tighter sealing in sensitive applications. The 58STA/STX furnaces are approved for use with natural or propane gas, and the 58STX – Low NOx units are designed for California installations and meet 40 ng/J NOx emissions. Can be installed in air quality management districts with a 40 ng/J NOx emissions requirement.

STANDARD FEATURES

- **QuieTech™ noise reduction system**
- **Microprocessor based control center**
 - Enhanced diagnostics with LED and reflective sight glass.
 - Stores fault codes during power outages.
 - Adjustable heating air temperature rise
 - Adjustable cooling airflow
- **4-way Multipoise furnace, 13 vent applications**
- **Compact design – only 33-1/3 in. (847 mm) tall**
- **Power Heat™ Igniter**
- **Draft safeguard switch to ensure proper furnace venting**
- **Inner door for tighter sealing**
- **Cabinet air leakage less than 2.0% at 1.0 in. W.C. and cabinet air leakage less than 1.4% at 0.5 in. W.C. when tested in accordance with ASHRAE standard 193**
- **HYBRID HEAT® Dual Fuel System compatible**
- **All models are chimney friendly when used with accessory vent kit**
- **Twinning in Upflow, Downflow and Horizontal**
- **Residential installations eligible for consumer financing through the Retail Credit Program**

MODEL NUMBER NOMENCLATURE

58STA		045	100	08
58STA 4-Way Multipoise 58STX Low NOx version				Nominal Cooling Size (Airflow at .5 e.s.p.) (400 CFM per 12,000 Btuh) 08—800 CFM 12—1200 CFM 14—1400 CFM 16—1600 CFM 20—2000 CFM 22—2200 CFM
Input Capacity				Series Number
045—44,000 Btuh	110—110,000 Btuh			
070—66,000 Btuh	135—132,000 Btuh			
090—88,000 Btuh	155—154,000 Btuh			

For California Residents:

For installation in SCAQMD only: This furnace does not meet the SCAQMD Rule 1111 14 ng/J NOx emission limit, and thus is subject to a mitigation fee of up to \$450. This furnace is not eligible for the Clean Air Furnace Rebate Program: www.CleanAirFurnaceRebate.com

FURNACE COMPONENTS

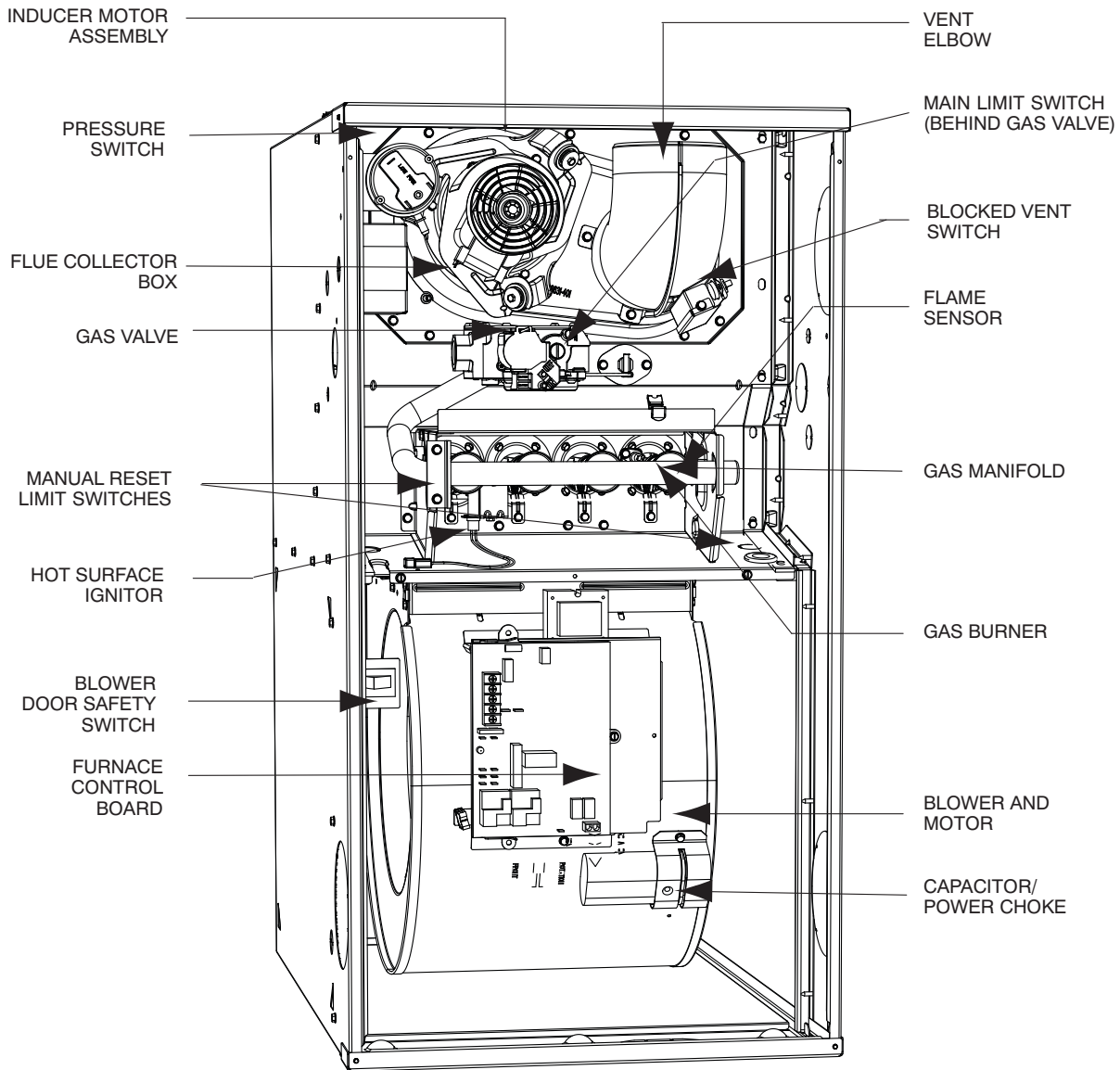

A10308

NOTE: The 58STA/STX Furnaces are factory shipped for use with natural gas. These furnaces can be field-converted for propane gas with a factory-authorized and listed accessory conversion kit.

58STA/STX

DIMENSIONS

REV	DATE	BY	CHK	APP
1				
2				

NOTES:

- Doors may vary by model.
- Two additional 7/8-in. (22 mm) diameter holes are located in the top plate.
- Minimum return-air openings at furnace, based on metal duct. If flex duct is used, see flex duct manufacturer's recommendations for equivalent diameters.
 - For 800 CFM-16-in. (406 mm) round or 14 1/2 x 12-in. (368 x 305 mm) rectangle.
 - For 1200 CFM-20-in. (508 mm) round or 14 1/2 x 19 1/2-in. (368 x 495 mm) rectangle.
 - For 1600 CFM-22-in. (559 mm) round or 14 1/2 x 22 1/16-in. (368 x 560mm) rectangle.
- Return air above 1800 CFM may require one of the following configurations:
 - sides, 1 side and a bottom only for return air. See Air Delivery table in this document for specific use to allow for sufficient airflow to the furnace.

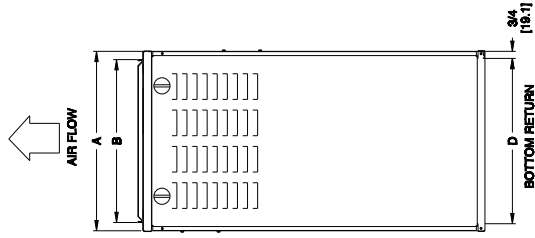
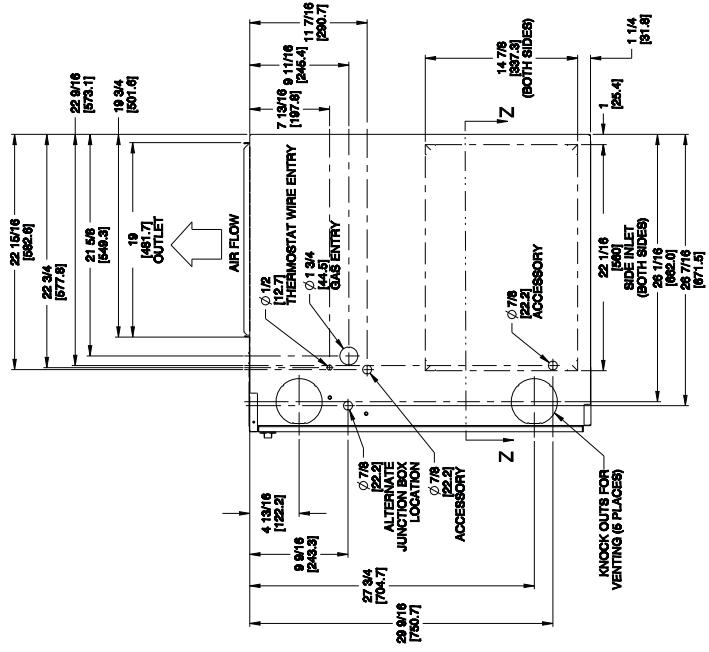
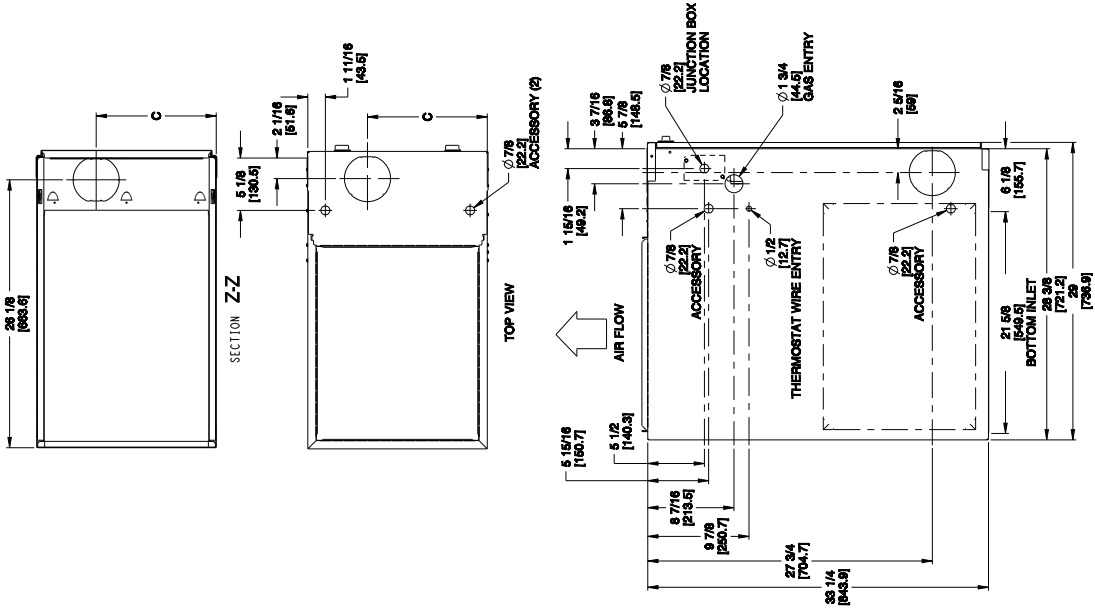

NOTE: ALL DIMENSIONS IN INCH [mm]

58STA/STX

FURNACE SIZE	A CABINET WIDTH IN (mm)	B OUTLET WIDTH IN (mm)	C TOP AND BOTTOM FLUE COLLAR	D BOTTOM INLET WIDTH	VENT CONNECTION SIZE	SHIP WEIGHT LB (KG)
045-08	14-3/16 (360)	12-9/16 (319)	9-5/16 (237)	12-11/16 (322)	4 (102)	104 (47)
045-12	14-3/16 (360)	12-9/16 (319)	9-5/16 (237)	12-11/16 (322)	4 (102)	107 (49)
070-08	14-3/16 (360)	12-9/16 (319)	9-5/16 (237)	12-11/16 (322)	4 (102)	111 (50)
070-12	14-3/16 (360)	12-9/16 (319)	9-5/16 (237)	12-11/16 (322)	4 (102)	115 (52)
070-16	17-1/2 (445)	15-7/8 (403)	11-9/16 (294)	16-1/8 (410)	4 (102)	126 (57)
090-14	17-1/2 (445)	15-7/8 (403)	11-9/16 (294)	16-1/8 (410)	4 (102)	127 (58)
090-16	21 (533)	19-3/8 (492)	13-5/16 (338)	19-1/2 (495)	4 (102)	140 (64)
090-20	21 (533)	19-3/8 (492)	13-5/16 (338)	19-1/2 (495)	4 (102)	146 (66)
110-12	17-1/2 (445)	15-7/8 (403)	11-9/16 (294)	16-1/8 (410)	4 (102)	135 (61)
110-16	21 (533)	19-3/8 (492)	13-5/16 (338)	19-1/2 (495)	4 (102)	146 (66)
110-22	21 (533)	19-3/8 (492)	13-5/16 (338)	19-1/2 (495)	4 (102)	152 (69)
135-16	21 (533)	19-3/8 (492)	13-5/16 (338)	19-1/2 (495)	4 (102)*	149 (68)
135-22	24-1/2 (622)	22-7/8 (581)	15-1/16 (383)	23 (584)	4 (102)*	163 (74)
155-20	24-1/2 (622)	22-7/8 (581)	15-1/16 (383)	23 (584)	4 (102)*	170 (77)

*135 and 155 size furnaces require a 5 or 6-in. (127 or 152 mm) vent. Use a vent adapter between furnace and vent stack. See Installation Instructions for complete installation requirements.

SPECIFICATIONS

UNIT SIZE		045-08	045-12	070-08	070-12	070-16	090-14	090-16
RATINGS AND PERFORMANCE								
Input Btuh*	58STX Upflow; all 58STA	44,000	44,000	66,000	66,000	66,000	88,000	88,000
Nonweatherized ICS	58STX Downflow/ Horizontal	42,000	42,000	63,000	63,000	63,000	84,000	84,000
Output Capacity (Btuh)†	58STX Upflow; all 58STA	35,000	36,000	53,000	54,000	53,000	71,000	71,000
Nonweatherized ICS	58STX Downflow/ Horizontal	34,000	34,000	51,000	51,000	51,000	68,000	68,000
AFUE‡		80.0	80.0	80.0	80.0	80.0	80.0	80.0
Certified Temperature Rise Range – °F (°C)		30-60 (17-33)	20-50 (11-28)	40-70 (22-39)	30-60 (17-33)	25-55 (14-30)	40-70 (22-39)	30-60 (17-33)
Certified External Static Pressure	Heat/Cool	0.10/0.50	0.10/0.50	0.12/0.50	0.12/0.50	0.12/0.50	0.15/0.50	0.15/0.50
Airflow CFM‡	Heating	865	1250	720	1195	1350	1300	1505
	Cooling	835	1160	870	1200	1505	1385	1635
ELECTRICAL								
Unit Volts–Hertz–Phase		115-60-1						
Operating Voltage Range	Min-Max	104-127						
Maximum Unit Amps		5.2	7.2	5.1	7.2	9.5	8.6	10.0
Maximum Wire Length (Measure 1 Way in Ft (M))		49 (14.9)	37 (11.2)	51 (15.5)	38 (11.5)	29 (8.8)	32 (9.7)	28 (8.5)
Minimum Wire Size		14						
Maximum Fuse or Ckt Bkr Size (Amps)**		15						
Transformer (24v)		40va						
External Control	Heating	12va						
Power Available	Cooling	35va						
Air Conditioning Blower Relay		Standard						
CONTROLS								
Limit Control		SPST						
Heating Blower Control		Solid-State Time Operation						
Burners (Monoport)		2	2	3	3	3	4	4
Gas Connection Size		1/2-in. NPT						
GAS CONTROLS								
Gas Valve (Redundant)	Mfr.	White-Rodgers						
	Min. inlet pressure (In. W.C.)	4.5 (Natural Gas)						
	Max. inlet pressure (In. W.C.)	13.6 (Natural Gas)						
Ignition Device		Hot Surface						
Factory-installed orifice		Size 43						
BLOWER DATA								
Direct-Drive Motor HP (PSC)		1/5	1/3	1/5	1/3	1/2	1/3	1/2
Motor Full Load Amps		2.8	5.2	2.8	5.2	7.1	5.2	7.1
RPM (Nominal)-Speeds		1075-3	1075-3	1075-3	1075-3	1075-3	1075-3	1075-3
Blower Wheel Diameter x Width – In. (mm)		10 x 6 (254 x 152)	10 x 6 (254 x 152)	10 x 6 (254 x 152)	10 x 6 (254 x 152)	11 x 8 (279 x 203)	10 x 8 (254 x 203)	10 x 10 (254 x 254)

58STA/STX

* Gas input ratings are certified for elevations to 2000 ft. (610 M). In USA, For elevations above 2000 ft (610 M), reduce ratings 4 percent for each 1000 ft (305 M) above sea level. Refer to National Fuel Gas Code NFPA 54/ANSI Z223.1–2012 Table F.4 or furnace installation instructions.

† Capacity in accordance with U.S. Government DOE test procedures.

‡ Airflow shown is for bottom only return-air supply for the as-shipped speed tap. For air delivery above 1800 CFM, see Air Delivery table for other options. A filter is required for each return-air supply. An airflow reduction of up to 7 percent may occur when using the factory-specified 4-5/16-in. (110 mm) wide, high efficiency media filter.

** Time–delay type is recommended.

ICS Isolated Combustion System

SPECIFICATIONS (continued)

UNIT SIZE		090-20	110-12	110-16	110-22	135-16	135-22	155-20
RATINGS AND PERFORMANCE								
Input Btuh*	58STX Upflow; all 58STA	88,000	110,000	110,000	110,000	132,000	132,000	154,000
Nonweatherized ICS	58STX Downflow/Horizontal	84,000	105,000	105,000	105,000	126,000	126,000	147,000
Output Capacity (Btuh)†	58STX Upflow; all 58STA	71,000	89,000	89,000	89,000	107,000	107,000	125,000
Nonweatherized ICS	58STX Downflow/Horizontal	68,000	85,000	85,000	85,000	102,000	102,000	119,000
AFUE‡		80.0	80.0	80.0	80.0	80.0	80.0	80.0
Certified Temperature Rise Range °F (°C)		25-55 (14-30)	50-80 (28-44)	40-70 (22-39)	30-60 (17-33)	50-80 (28-44)	40-70 (22-39)	45-75 (25-41)
Certified External Static Pressure	Heat/Cool	0.15/0.50	0.20/0.50	0.20/0.50	0.20/0.80	0.20/0.50	0.20/0.50	0.20/0.50
Airflow CFM‡	Heating	1900	1295	1515	1840	1480	1830	1790
	Cooling	2025	1355	1655	2160	1710	2085	2215
ELECTRICAL								
Unit Volts—Hertz—Phase		115-60-1						
Operating Voltage Range	Min-Max	104-127						
Maximum Unit Amps		14.1	8.6	10.2	15.1	10.5	14.5	15.4
Maximum Wire Length (Measure 1 Way in Ft (M))		31 (9.4)	32 (9.7)	27 (8.2)	29 (8.8)	27 (8.2)	30 (9.1)	29 (8.8)
Minimum Wire Size		12	14		12	14	11	
Maximum Fuse or Ckt Bkr Size (Amps)**		20	15		20	15	20	
Transformer (24v)		40va						
External Control	Heating	12va						
Power Available	Cooling	35va						
Air Conditioning Blower Relay		Standard						
CONTROLS								
Limit Control		SPST						
Heating Blower Control		Solid-State Time Operation						
Burners (Monoport)		4	5	5	5	6	6	7
Gas Connection Size		1/2-in. NPT						
GAS CONTROLS								
Gas Valve (Redundant)	Mfr.	White-Rodgers						
	Min. inlet pressure (In. W.C.)	4.5 (Natural Gas)						
	Max. inlet pressure (In. W.C.)	13.6 (Natural Gas)						
Ignition Device		Hot Surface						
Factory-installed orifice		Size 43						
BLOWER DATA								
Direct-Drive Motor HP (PSC)		3/4	1/3	1/2	3/4	1/2	3/4	3/4
Motor Full Load Amps		11.8	5.2	7.1	11.8	7.1	11.8	11.8
RPM (Nominal)-Speeds		1075-3	1075-3	1075-3	1075-3	1075-3	1075-3	1075-3
Blower Wheel Diameter x Width — In. (mm)		11 x 11 (279 x 279)	10 x 8 (254 x 203)	10 x 10 (254 x 254)	11 x 11 (279 x 279)	10 x 10 (254 x 254)	11 x 11 (279 x 279)	11 x 11 (279 x 279)

* Gas input ratings are certified for elevations to 2000 ft. (610 M). In USA, for elevations above 2000 ft. (610 M), reduce ratings 4 percent for each 1000 ft. (305 M) above sea level. Refer to National Fuel Gas Code NFPA 54/ANSI Z223.1-2012 Table F.4 or furnace installation instructions.

† Capacity in accordance with U.S. Government DOE test procedures.

‡ Airflow shown is for bottom only return-air supply for the as-shipped speed tap. For air delivery above 1800 CFM, see Air Delivery table for other options. A filter is required for each return-air supply. An airflow reduction of up to 7 percent may occur when using the factory-specified 4-5/16-in. (110 mm) wide, high efficiency media filter.

** Time-delay type is recommended.

ICS Isolated Combustion System

CARRIER ACCESSORIES

DESCRIPTION 58STA/STX	PART NO.	045-08	045-12	070-08	070-12	070-16	090-14	090-16	090-20	110-12	110-16	110-22	135-16	135-22	155-20
Media Filter Cabinet	FILCABXL0016	X	X	X	X	X	X			X					
	FILCABXL0020							X	X		X	X	X		
	FILCABXL0024													X	X
Cartridge Media Filter	FILCCCAR0016	X	X	X	X	X	X			X					
	FILCCCAR0020							X	X		X	X	X		
	FILCCCAR0024													X	X
EZ Flex Media Filter with End Caps	EXPXXUNV0016	X	X	X	X	X	X			X					
	EXPXXUNV0020							X	X		X	X	X		
	EXPXXUNV0024													X	X
Replacement EZ Flex Filter Media	EXPXXFIL0016	X	X	X	X	X	X			X					
	EXPXXFIL0020							X	X		X	X	X		
	EXPXXFIL0024													X	X
External Bottom Return Filter Rack	KGBFR0401B14	X	X	X	X										
	KGBFR0501B17					X	X			X					
	KGBFR0601B21							X	X		X	X	X		
	KGBFR0701B24													X	X
Unframed Filter 3/4-in. (19 mm)	KGAWF1306UFR	X	X	X	X	X	X			X					
	KGAWF1406UFR							X	X		X	X	X		
	KGAWF1506UFR													X	X
Flue Extension	KGAFE0112UPH	X	X	X	X	X	X	X	X	X	X	X	X	X	X
Twinning Kit	KGATW0601HSI	X	X	X	X	X	X	X	X	X	X	X	X	X	X
Combustible Floor Base	KGASB0201ALL	X	X	X	X	X	X	X	X	X	X	X	X	X	X
Downflow Vent Guard	KGBVG0101DFG	X	X	X	X	X	X	X	X	X	X	X	X	X	X
Vent Extension Kit	KGAVE0101DNH	X	X	X	X	X	X	X	X	X	X	X	X	X	X
Chimney Adapter Kit	KGACA02014FC	X	X	X	X	X	X	X	X	X	X	X			
	KGACA02015FC												X	X	X
Natural-to-Propane Conversion Kit*	KGBNP50011SP	X	X	X	X	X	X	X	X	X	X	X	X	X	X
Propane-to-Natural Conversion Kit	KGBPN42011SP	X	X	X	X	X	X	X	X	X	X	X	X	X	X
Label Kit	KGALB0301KIT	X	X	X	X	X	X	X	X	X	X	X	X	X	X
Gas Orifice	LH32DB207	See Installation Instructions for model, altitude, and heat value usages.													
	LH32DB202														
	LH32DB200														
	LH32DB205														
	LH32DB208														
	LH32DB078														
	LH32DB076														
	LH32DB203														
	LH32DB201														
	LH32DB206														
	LH32DB209														
LH32DB210															

58STA/STX

* Factory-authorized and field installed. Fuel conversion kits are CSA (formerly AGA/CGA) recognized.
X = Accessory

CARRIER ACCESSORIES

58STA/STX

Accessories	
ELECTRONIC AIR CLEANER (EAC)	Model EACB
MECHANICAL AIR CLEANER	Models EZXCAB, FILCAB
HUMIDIFIER	Model HUM
HEAT RECOVERY VENTILATOR	Model HRV
ENERGY RECOVERY VENTILATOR	Model ERV
UV LIGHTS	Model UVL
THERMOSTAT – NON-PROGRAMMABLE	For use with 1-speed Air Conditioner – deg. F/C, Auto Changeover – TP–NAC, TC–NAC
	For use with 1-speed Heat Pump – deg. F/C, Auto Changeover – TP–NHP, TC–NHP*
	For use with 2-speed Air Conditioner – deg. F/C, Auto Changeover – TP–NRH*
	For use with multi-use / stage configurations – deg. F/C, Auto Changeover/Temperature and Humidity Control – TP–PRH†
THERMOSTAT – PROGRAMMABLE	For use with 1-speed Air Conditioner – deg. F/C, Auto Changeover, 7-Day Programmable – TP–PAC
	For use with 1-speed Heat Pump – deg. F/C, Auto Changeover, 7-Day Programmable – TP–PHP*
	For use with 2-speed Air Conditioner – deg. F/C, Auto Changeover, 7-Day Programmable – TP–PRH*
	For use with 1-speed Air Conditioner – deg. F/C, 5–2 Day Programmable – TP–PAC
	For use with multi-stage applications – deg. F/C, Auto Changeover, 7-Day Programmable – TC–PHP‡
	For multi-use / stage configurations – deg. F/C, Auto Changeover, 7-Day Programmable/Temperature and Humidity Control –TP–PRH†
ZONING CONTROL	Comfort™ Series 3-Zone Kit – ZONECC3ZAC01, ZONECC3ZHP01
	2 Performance™ Series ComfortZone™ II Zoning/Temperature and Humidity Control – ZONECC2KIT01–B
	4 Performance™ Series ComfortZone™ II Zoning/Temperature and Humidity Control – ZONECC4KIT01–B
	8 Performance™ Series ComfortZone™ II Zoning/Temperature and Humidity Control – ZONECC8KIT01–B

* Model HP and 2S thermostat must be field converted to air conditioner operation.
 † Thermostat Control can be configured for multiple use and staging, it must be configured for each specific application.
 ‡ Dual Fuel thermostat is used with furnace and heat pump application.

TYPICAL WIRING SCHEMATIC

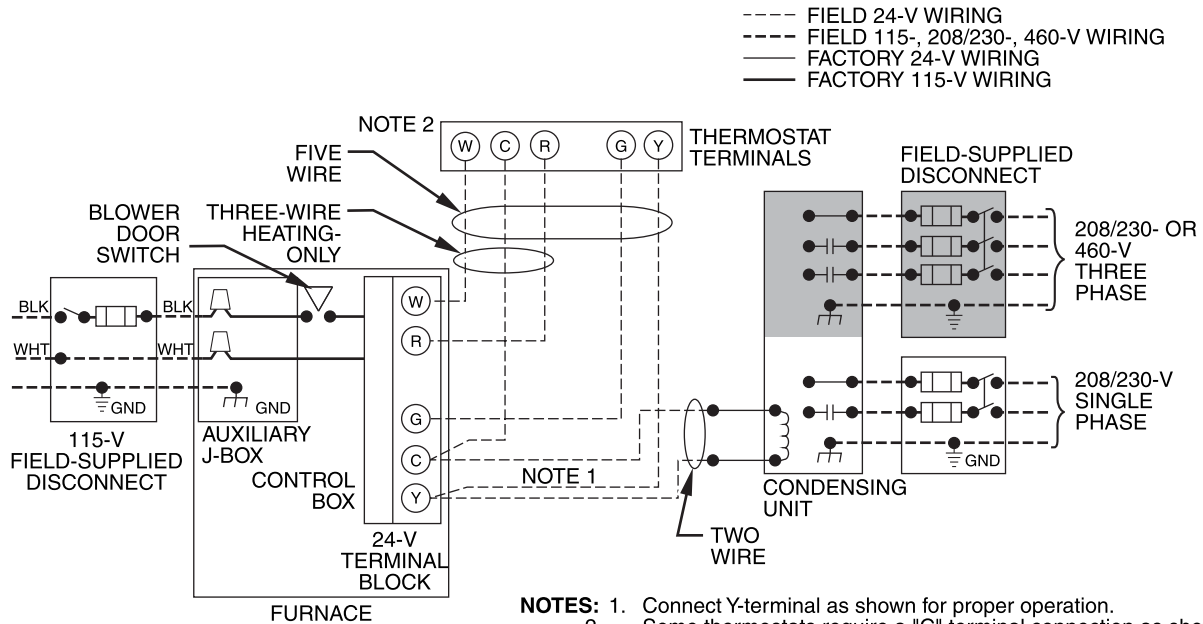

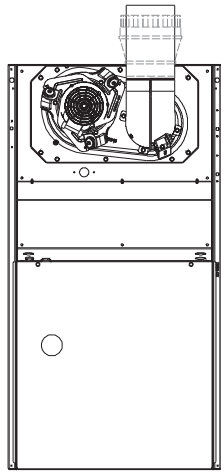

SEE NOTES: 1,2,4,7,8,9
UPFLOW

A02058

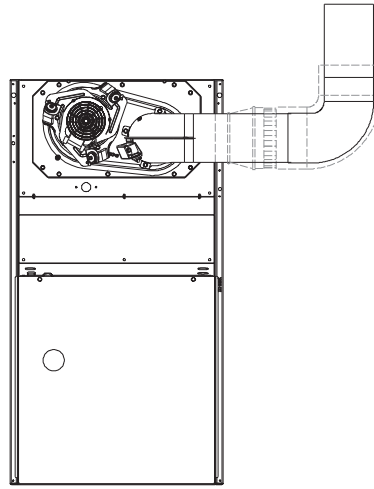

SEE NOTES: 1,2,3,4,7,8,9
UPFLOW

A02059

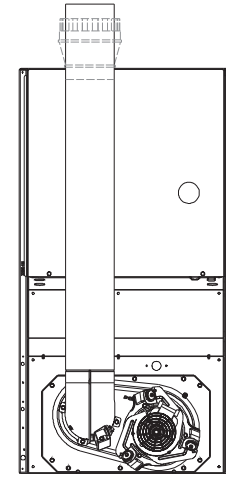

SEE NOTES: 1,2,4,5,7,8,9
DOWNFLOW

A02061

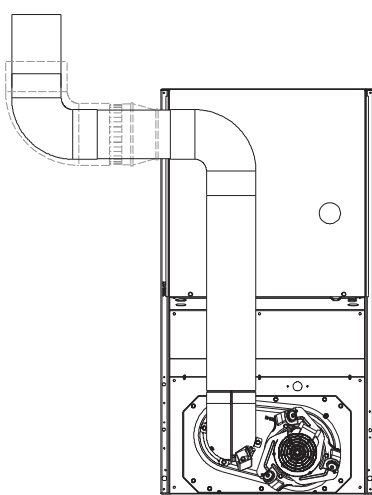

SEE NOTES: 1,2,3,4,5,7,8,9
DOWNFLOW

A02060

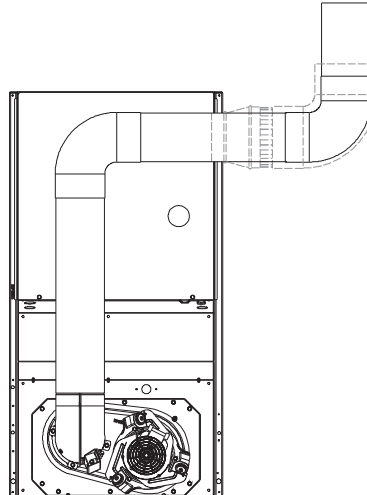

SEE NOTES: 1,2,3,4,5,7,8,9
DOWNFLOW

A02063

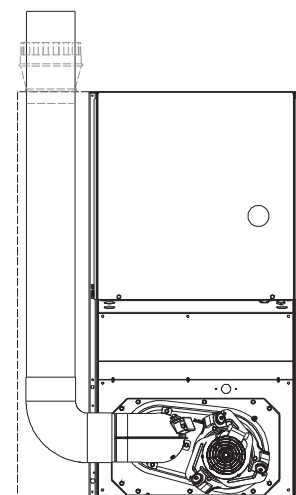

SEE NOTES: 1,2,4,5,6,7,8,9
DOWNFLOW

A02062

Venting Notes

1. For common vent, vent connector sizing and vent material: United States, latest edition of the National Fuel Gas Code (NFGC), ANSI Z223.1/NFPA 54.
2. Immediately increase to 5-in. (127 mm) vent connector outside furnace casing when 5-in. (127 mm) vent connector required, refer to Note 1.
3. Side outlet vent for upflow and downflow installations must use Type B vent immediately after exiting the furnace, except when Downflow Vent Guard is used in downflow position.
4. Type B vent where required, refer to Note 1.
5. 4-in. (102 mm) single wall vent must be used inside furnace casing and the Downflow Vent Guard Kit.
6. Accessory Downflow Vent Guard Kit required in downflow installations with bottom vent configuration.
7. Chimney Adapter Kit required for exterior masonry chimney applications. Refer to Chimney Adapter Kits for sizing and complete application details.
8. Secure vent connector to furnace elbow with (2) corrosion-resistant sheet metal screws, space approximately 180° apart.
9. Secure all other single wall vent connector joints with (3) corrosion-resistant screws spaced approximately 120° apart. Secure Type B vent connectors per vent connector manufacturer's recommendations.

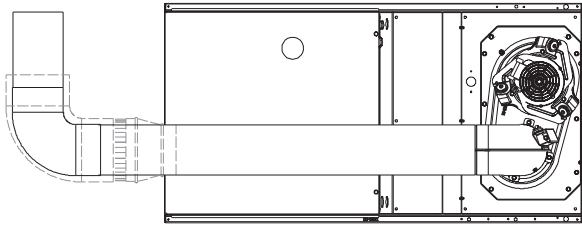

SEE NOTES 1,2,4,5,7,8,9
HORIZONTAL RIGHT

A02068

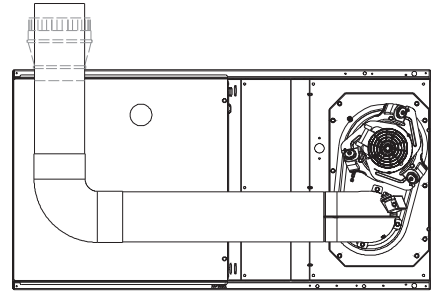

SEE NOTES 1,2,4,5,7,8,9
HORIZONTAL RIGHT

A02070

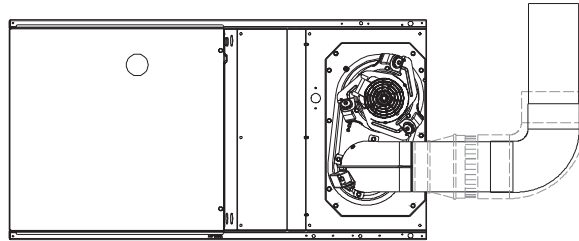

SEE NOTES 1,2,4,7,8,9
HORIZONTAL RIGHT

A02069

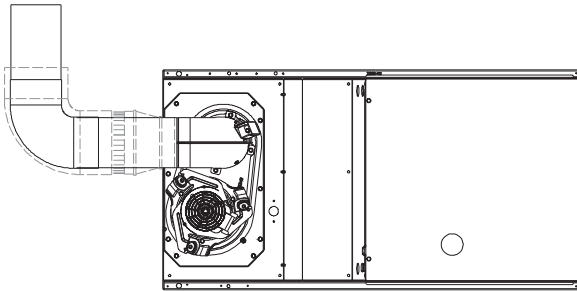

SEE NOTES 1,2,4,7,8,9
HORIZONTAL LEFT

A02064

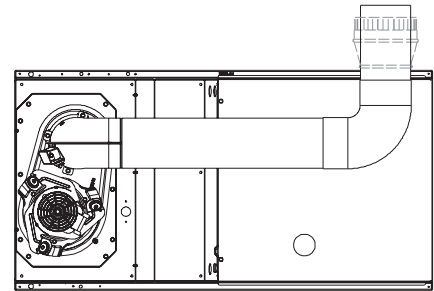

SEE NOTES 1,2,4,5,7,8,9
HORIZONTAL LEFT

A02065

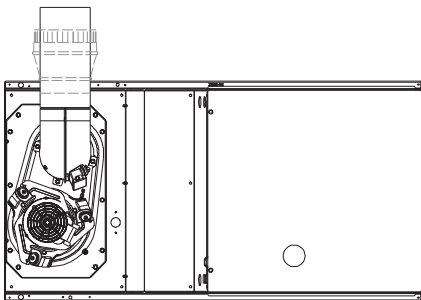

SEE NOTES 1,2,4,5,7,8,9
HORIZONTAL LEFT

A02066

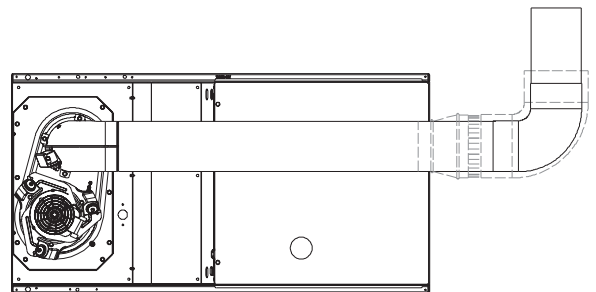

SEE NOTES 1,2,4,5,7,8,9
HORIZONTAL LEFT

A02067

AIR DELIVERY – CFM (With Filter)

FURNACE SIZE	RETURN–AIR INLET	SPEED	EXTERNAL STATIC PRESSURE (In. W.C.)									
			0.1	0.2	0.3	0.4	0.5	0.6	0.7	0.8	0.9	1.0
045–08	Bottom or Side(s)	High	1035	995	945	895	835	770	675	565	390	195
		Med–High	865	830	790	745	690	625	545	440	250	195
		Med–Low	760	720	680	635	580	520	445	345	220	195
045–12	Bottom or Side(s)	High	1440	1375	1305	1240	1160	1070	975	870	730	560
		Med–High	1360	1300	1240	1175	1115	1040	950	850	725	575
		Med–Low	1250	1210	1160	1100	1040	965	885	790	670	520
070–08	Bottom or Side(s)	High	1030	1005	965	925	870	810	740	645	465	280
		Med–High	835	815	790	755	710	660	590	480	325	205
		Med–Low	725	700	675	635	595	545	460	350	250	—
070–12	Bottom or Side(s)	High	1425	1375	1320	1265	1200	1125	1035	940	830	655
		Med–High	1320	1280	1240	1205	1140	1075	995	905	790	620
		Med–Low	1200	1175	1145	1105	1050	990	920	840	725	555
070–16	Bottom or Side(s)	High	1755	1700	1635	1570	1505	1435	1350	1260	1160	1055
		Med–High	1550	1520	1475	1430	1375	1310	1240	1155	1070	970
		Med–Low	1355	1340	1310	1280	1240	1190	1125	1060	975	890
090–14	Bottom or Side(s)	High	1605	1570	1535	1465	1385	1285	1175	1055	895	645
		Med–High	1470	1445	1410	1380	1300	1220	1115	990	830	600
		Med–Low	1310	1295	1265	1230	1195	1120	1025	915	710	565
090–16	Bottom or Side(s)	High	1940	1880	1805	1720	1635	1540	1425	1290	1090	830
		Med–High	1740	1700	1650	1590	1525	1440	1335	1195	1010	820
		Med–Low	1505	1505	1480	1440	1375	1300	1190	1045	890	740
090–20	Bottom Only	High	2405	2310	2220	2130	2025	1920	1790	1660	1530	1350
		Med–High	2170	2110	2040	1970	1895	1785	1675	1565	1420	1260
		Med–Low	1920	1875	1835	1780	1715	1630	1535	1420	1275	1135
	Both Sides or 1 Side & Bottom	High	2530	2450	2365	2270	2165	2065	1940	1805	1670	1505
		Med–High	2230	2170	2110	2050	1985	1890	1780	1660	1525	1360
		Med–Low	1895	1890	1845	1815	1755	1685	1600	1480	1350	1180
	1 Side Only	High	2475	2395	2300	2200	2090	1985	1865	1730	1585	1425
		Med–High	2105	2145	2070	2010	1940	1845	1735	1620	1475	1325
		Med–Low	1850	1860	1810	1770	1715	1650	1555	1445	1310	1150
110–12	Bottom or Side(s)	High	1600	1550	1490	1425	1355	1260	1135	990	785	530
		Med–High	1475	1435	1395	1335	1285	1185	1070	890	725	450
		Med–Low	1315	1295	1265	1220	1155	1080	985	810	675	440
110–16	Bottom or Side(s)	High	1980	1915	1835	1750	1655	1495	1365	1185	965	700
		Med–High	1745	1710	1650	1560	1450	1340	1205	1090	865	605
		Med–Low	1530	1515	1470	1400	1310	1215	1095	990	830	670
110–22	Bottom Only	High	2485	2415	2340	2255	2160	2080	1950	1840	1720	1565
		Med–High	2135	2100	2060	2000	1930	1860	1765	1670	1555	1425
		Med–Low	1855	1840	1815	1775	1725	1675	1600	1510	1405	1290
	Bottom Sides or 1 Side & Bottom	High	—	—	2355	2285	2190	2090	1965	1850	1705	1535
		Med–High	2140	2100	2050	1990	1935	1865	1760	1670	1545	1410
		Med–Low	1855	1840	1815	1775	1725	1675	1600	1510	1405	1290
	1 Side Only	High	2495	2440	2370	2290	2205	2120	2015	1910	1775	1625
		Med–High	2030	2025	2000	1950	1905	1850	1750	1660	1555	1425
		Med–Low	—	1735	1725	1695	1650	1595	1535	1455	1335	1230

58STA/STX

* A filter is required for each return–air inlet. Airflow performance included 3/4–in. (19 mm) washable filter media such as contained in factory–authorized accessory filter rack. To determine airflow performance without this filter, assume an additional 0.1 In. W.C. available external static pressure.
 — Indicates unstable operating conditions.

AIR DELIVERY – CFM (With Filter) (Continued)

FURNACE SIZE	RETURN–AIR INLET	SPEED	EXTERNAL STATIC PRESSURE (In. W.C.)									
			0.1	0.2	0.3	0.4	0.5	0.6	0.7	0.8	0.9	1.0
135–16	Bottom or Side(s)	High	2065	2000	1930	1835	1710	1590	1420	1235	1025	835
		Med–High	1790	1755	1705	1640	1550	1465	1295	1145	945	775
		Med–Low	1480	1480	1480	1450	1380	1295	1160	1005	855	670
135–22	Bottom Only	High	2445	2365	2280	2190	2085	1980	1850	1705	1520	1355
		Med–High	2130	2080	2025	1960	1880	1795	1690	1550	1405	1255
		Med–Low	1860	1830	1800	1755	1705	1630	1530	1415	1280	1140
	Bottom, Sides or 1 Side & Bottom	High	—	—	2355	2280	2160	2065	1930	1805	1655	1465
		Med–High	2120	2075	1995	1970	1905	1835	1735	1645	1515	1325
		Med–Low	1860	1830	1800	1755	1725	1630	1530	1415	1280	1140
1 Side Only	High	—	—	2215	2130	2030	1920	1795	1675	1540	1385	
	Med–High	2070	2015	1970	1935	1855	1765	1655	1550	1445	1265	
	Med–Low	1860	1830	1800	1755	1725	1630	1530	1415	1280	1140	
155–20	Bottom Only	High	2465	2430	2375	2305	2215	2110	2000	1865	1715	1530
		Med–High	2115	2095	2055	2005	1940	1845	1820	1675	1525	1390
		Med–Low	1800	1790	1770	1735	1695	1640	1570	1465	1345	1225
	Both Sides Or 1 Side & Bottom	High	—	—	2375	2285	2185	2105	1995	1870	1720	1555
		Med–High	2155	2125	2075	2015	1935	1830	1780	1635	1485	1365
		Med–Low	1800	1790	1770	1735	1695	1640	1570	1465	1345	1225
	1 Side Only	High	—	—	2260	2180	2070	1975	1865	1740	1595	1440
		Med–High	2140	2085	2020	1950	1850	1745	1695	1545	1415	1290
		Med–Low	1800	1790	1770	1735	1695	1640	1570	1465	1345	1225

* A filter is required for each return–air inlet. Airflow performance included 3/4–in. (19 mm) washable filter media such as contained in factory–authorized accessory filter rack. To determine airflow performance without this filter, assume an additional 0.1 In. W.C. available external static pressure.

— Indicates unstable operating conditions.

⚠ WARNING

FIRE, EXPLOSION, ASPHYXIATION HAZARD

Improper adjustment, alteration, service, maintenance, or installation can cause serious injury or death.

Read and follow instructions and precautions in User's Information Manual provided with this furnace. Installation and service must be performed by a qualified service agency or the gas supplier.

⚠ CAUTION

Check entire gas assembly for leaks after lighting this appliance.

INSTALLATION

1. This furnace must be installed in accordance with the manufacturer's instructions and local codes. In the absence of local codes, follow the National Fuel Gas Code ANSI Z223.1 / NFPA54 or CSA B-149. 1 Gas Installation Code.
2. This furnace must be installed so there are provisions for combustion and ventilation air. See manufacturer's installation information provided with this appliance.

OPERATION

This furnace is equipped with manual reset limit switch(es) in burner compartment to protect against overheat conditions that can result from inadequate combustion air supply or blocked vent conditions.

1. Do not bypass limit switches.
2. If a limit opens, call a qualified serviceman to correct the condition and reset limit switch.

INSTALLATION

MINIMUM INCHES CLEARANCE TO COMBUSTIBLE CONSTRUCTION

This forced air furnace is equipped for use with natural gas at altitudes 0 - 10,000 ft (0 - 3,050m). An accessory kit, supplied by the manufacturer, shall be used to convert to propane gas use or may be required for some natural gas applications.

This furnace is for indoor installation in a building constructed on site.

This furnace may be installed on combustible flooring in alcove or closet at minimum clearance as indicated by the diagram from combustible material.

This furnace may be used with a Type B-1 Vent and may be vented in common with other gas fired appliances.

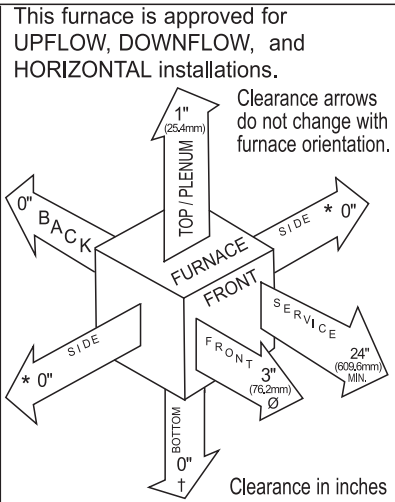

Vent Clearance to combustibles:
 For Single Wall vents 6 inches (6 po).
 For Type B-1 vent type 1 inch (1 po).

MINIMUM INCHES CLEARANCE TO COMBUSTIBLE CONSTRUCTION

DOWNFLOW POSITIONS:

- † Installation on non-combustible floors only.
 For Installation on combustible flooring only when installed on special base, Part No. KGASB0201ALL or NAHA01101SB, Coil Assembly, Part No. CAR, CAP, CNPV, CNRV, END4X, ENW4X, WENC, WTNC, WENW OR WTNW.
- ∅ 18 inches front clearance required for alcove.
- * Indicates supply or return sides when furnace is in the horizontal position. Line contact only permissible between lines formed by intersections of the Top and two Sides of the furnace jacket, and building joists, studs or framing.



336996-101 REV. C

58STA/STX

A10269



ISO 9001
QMI-SAI Global



Use of the AHRI Certified™ Mark indicates a manufacturer's participation in the program. For verification of certification for individual products, go to www.ahridirectory.org.



**Always Ask For
FACTORY
AUTHORIZED
PARTS**

GUIDE SPECIFICATIONS

Gas Furnace

58STA/STX

General

SYSTEM DESCRIPTION

Furnish a _____ fixed capacity gas-fired furnace for use with natural gas or propane (factory authorized conversion kit required for propane); furnish cold air return plenum.

QUALITY ASSURANCE

Unit will be designed, tested and constructed to the current ANSI Z 21.47/CSA 2.3 design standard for gas-fired central furnaces.

Unit will be 3rd party certified by CSA to the current ANSI Z 21.47/CSA 2.3 design standard for gas-fired central furnaces.

Unit will carry the CSA Blue Star® label.

Unit efficiency testing will be performed per the current DOE test procedure as listed in the Federal Register.

Unit will be certified for capacity and efficiency and listed in the latest AHRI Consumer's Directory of Certified Efficiency Ratings.

Unit shall carry the current Federal Trade Commission Energy Guide efficiency label.

DELIVERY, STORAGE AND HANDLING

Unit shall be shipped as single package only and is stored and handled per unit manufacturer's recommendations.

WARRANTY (for inclusion by specifying engineer)

Warranty certificate available upon request.

Products

EQUIPMENT

Components shall include: slow-opening gas valve to reduce ignition noise, regulate gas flow, with electric switch gas shut-off; flame proving sensor, hot surface igniter, pressure switch assembly, flame rollout switch, blower and inducer assembly, 40va transformer; low-voltage (heating) (heating/cooling) thermostat.

Blower Wheel and Blower Motor

Galvanized blower wheel shall be centrifugal type, statically and dynamically balanced. Blower motor of PSC type shall be permanently lubricated with sealed bearings, of _____hp, and shall be multiple-speed direct drive. Blower motor shall be soft mounted to the blower scroll to reduce vibration transmission.

Filters

Furnace may have reusable-type filters. Filter shall be _____ in. (mm) (x) _____ in. (mm). An accessory high efficiency Media Filter is available as an option. _____ Media Filter.

Casing

Casing shall be of .030 in. (.76) thickness minimum, pre-painted steel.

Inducer Motor

Inducer motor shall be soft mounted to reduce vibration transmission.

Draft Safeguard Switch

Draft Safeguard Switch (blocked vent safeguard) shall be factory installed to reduce the possibility of vent gas infiltration due to a blocked or restricted vent pipe.

Heat Exchangers

Heat exchangers shall be a 4-Pass 20 gage aluminized steel of fold-and-crimp sectional design when applied operating under negative pressure.

Controls

Control shall include a micro-processor based integrated electronic control board with at least 11 service troubleshooting codes displayed via enhanced flashing LED diagnostic light on the control, a self-test feature that checks all major functions of the furnace within one minute, and a non-volatile memory replaceable automotive-type circuit protection fuse. Multiple operational settings available including, separate blower speeds for heating, cooling and continuous fan. Continuous fan speed may be adjusted from the thermostat. Cooling airflow will be selectable between 350 or 400 CFM per ton of air conditioning.

OPERATING CHARACTERISTICS

Heating Capacity shall be _____ Btuh input; _____ Btuh output capacity.

Fuel Gas Efficiency shall be 80% AFUE. Air delivery shall be _____ CFM minimum at 0.50 In. W.C. external static pressure.

Dimensions shall be: depth _____ in. (mm); width _____ in. (mm); height _____ in. (mm) (casing only). Height shall be _____ in. (mm) with A/C coil and _____ in. (mm) overall with plenum.

ELECTRICAL REQUIREMENTS

Electrical supply shall be 115 volts, 60 Hz, single-phase (nominal). Minimum wire size shall be _____ AWG; maximum fuse size or circuit breaker shall be _____ Amps.

SPECIAL FEATURES

Refer to section of the product data sheet identifying accessories and descriptions for specific features and available enhancements.