

48TC
Single Package Rooftop
Gas Heating/Electric Cooling
Horizontal Air Flow Unit
with Puron® (R-410A) Refrigerant
15, 17.5, 20, 25 Tons – (Sizes 18, 21, 25, 29)



Product Data



(Unit shown with economizer and power exhaust.)

C10997



TABLE OF CONTENTS

	PAGE		PAGE
FEATURES AND BENEFITS	3	APPLICATION / SELECTION DATA	26
MODEL NUMBER NOMENCLATURE	4	COOLING CAPACITIES	28
FACTORY OPTIONS AND/OR ACCESSORIES	5	STATIC PRESSURE ADDERS	36
AHRI COOLING RATING TABLES	9	DAMPER, BARO RELIEF & PE PERFORMANCE .	37
HEAT RATING TABLE	9	FAN PERFORMANCE	39
SOUND PERFORMANCE TABLE	10	ELECTRICAL INFORMATION	42
MINIMUM / MAXIMUM AIRFLOW RATINGS	10	SEQUENCE OF OPERATION	47
PHYSICAL DATA	11	GUIDE SPECIFICATIONS	50
DIMENSIONS	15		
OPTIONS & ACCESSORIES WEIGHT ADDERS ...	25		



Your new 15 to 25 Ton WeatherMaker Carrier rooftop unit (RTU) was designed by customers for customers. With a newly designed cabinet that integrates “no-strip” screw collars, handled access panels, and more we’ve made your unit easy to install, easy to maintain, easy to use and reliable.

Easy to install:

These new WeatherMaker units are designed for dedicated factory-supplied horizontal air flow duct configurations. No special field kits are required. Designed to fit on pre-installed curbs by another manufacturer, these units also fit on past designed Carrier installed curbs with a new certified and authorized adapter curb. This new cabinet design also integrates a large control box that gives you room to work and room to mount Carrier accessory controls.

Easy to maintain:

Easy access handles by Carrier provide quick and easy access to all normally serviced components. Our “no-strip” screw system has superior holding power and guides screws into position while preventing the screw from stripping the unit’s metal. Take accurate pressure readings by reading system pressures with panels in place as compressors are strategically located to eliminate any air bypass.

Easy to use:

The newly designed, central terminal board by Carrier puts all your connections and troubleshooting points in one convenient place, standard. Most low voltage connections are made to the same board and make it easy to find what you’re looking for and easy to access it.

Reliable:

Each unit comes with precision sized and tested scroll compressor that is internally protected from over temperature and pressures. In addition, each refrigerant circuit is further protected with a high pressure and low pressure switch as well as containing a liquid line filter drier. Each unit is factory tested prior to shipment to help ensure unit operation once properly installed.

FEATURES AND BENEFITS

- Two stage cooling capability with independent circuits and control.
- High performance copper tube / aluminum plate (RTPF) fin condenser and evaporator coils with optional coating.
- EER's up to 10.8
- IEER's up to 11.0 with single speed indoor fan motor and 12.7 with SAV™ (Staged Air Volume) 2-speed/VFD indoor fan motor
- Gas heating efficiencies up to 81% thermal efficiency.
- Dedicated horizontal air flow duct configuration models. No field kits required.
- Utility connections through the side or bottom. Bottom connections are also in an enclosed environment to help prevent water entry. Field supplied couplings are required.
- Standardized components and layout. Standardized components and controls make service and stocking parts easier.
- Scroll compressors on all units. This makes service, stocking parts, replacement, and trouble-shooting easier.
- Precision sized TXV metering device on each refrigerant circuit.
- Easy-adjust, belt-drive motor available. Motor assembly also contains a fan belt break protection system on all models and reliable pillow block bearing system that allows lubrication thru front of the unit.
- Single-point gas / electrical connection.
- Sloped, composite drain pan sheds water; and won't rust.
- Standardized controls and control box layout. Standardized components and controls make stocking parts and service easier.
- Clean, large, easy to use control box.
- Color-coded wiring.
- Large, laminated wiring and power wiring drawings which are affixed to unit make troubleshooting easy.
- Single, central terminal board for test and wiring connections.
- Fast-access, handled, panels for easy access on normally accessed service panels.
- "No-strip" screw system guides screws into the panel and captures them tightly without stripping the screw, the panel, or the unit.
- Mechanical cooling (115°F to 35°F / 46°C to -2°C) standard on all models. Low ambient controller allows operation down to -20°F / -29°C
- Redundant gas valve for 2-stage gas heating capacity control with induced-draft flue exhaust design to help ensure no flue gas can escape into the indoor air stream.
- Exclusive IGC solid state gas controller for on board diagnostics with LED error code designation, burner control logic and energy saving indoor fan motor delay.
- 2-in (51mm) disposable filters on all units, with 4-in (102mm) filter track field-installed.
- Refrigerant filter-drier on each circuit.
- High and low pressure switches. Added reliability with high pressure switch and low pressure switch.
- Many factory-installed options ranging from air management economizers, 2 position dampers, manual outdoor air dampers, plus convenience outlets, disconnect switch and smoke detectors.
- Factory-installed Humidi-MiZer® adaptive dehumidification system.
- Standard Parts Warranty: 10 year aluminized heat exchanger, 5 year compressor, 1 year others.
- Optional Staged Air Volume (SAV) system utilizes a Variable Frequency Drive (VFD) to automatically adjust the indoor fan motor speed between cooling stages. Available on 2-stage cooling models 18-29 with electromechanical controls or RTU Open.

MODEL NUMBER NOMENCLATURE

Position:	1	2	3	4	5	6	7	8	9	10	11	12	13	14	15	16	17	18
Example:	4	8	T	C	D	D	2	5	A	5	A	5	-	0	A	0	A	0

Unit Heat Type

48 - Gas Heat Packaged Rooftop

Model Series - WeatherMaker™

TC - Standard Efficiency

Heat Options

D = Low Gas Heat
 E = Medium Gas Heat
 F = High Gas Heat
 S = Low Heat w/ Stainless Steel Exchanger
 R = Medium Heat w/ Stainless Steel Exchanger
 T = High Heat w/ Stainless Steel Exchanger

Refrig. Systems Options

D = Two stage cooling model
 E = Two stage cooling models with Humidi-MiZer

Cooling Tons

18 - 15 tons
 21 - 17.5 tons
 25 - 20 tons
 29 - 25 tons

Sensor Options

A = None
 B = RA Smoke Detector
 C = SA Smoke Detector
 D = RA + SA Smoke Detector
 E = CO₂
 F = RA Smoke Detector and CO₂
 G = SA Smoke Detector and CO₂
 H = RA + SA Smoke Detector and CO₂

Indoor Fan Options & Air Flow Configuration

5 = Standard Static / Horizontal Supply, Return Air Flow (except 29 size)
 6 = Medium Static / Horizontal Supply, Return Air Flow (Standard on 29 size models)
 7 = High Static / Horizontal Supply, Return Air Flow
 F = Medium Static High Efficiency Motor / Horizontal Supply, Return Air Flow
 G = High Static High Efficiency Motor / Horizontal Supply, Return Air Flow

Coil Options (RTPF) (Outdoor - Indoor - Hail Guard)

A = Al/Cu - Al/Cu
 B = Precoat Al/Cu - Al/Cu
 C = E-coat Al/Cu - Al/Cu
 D = E-coat Al/Cu - E-coat Al/Cu
 E = Cu/Cu - Al/Cu
 F = Cu/Cu - Cu/Cu
 M = Al/Cu -Al/Cu — Louvered Hail Guard
 N = Precoat Al/Cu - Al/Cu — Louvered Hail Guard
 P = E-coat Al/Cu - Al/Cu — Louvered Hail Guard
 Q = E-coat Al/Cu - E-coat Al/Cu — Louvered Hail Guard
 R = Cu/Cu - Al/Cu — Louvered Hail Guard
 S = Cu/Cu - Cu/Cu — Louvered Hail Guard

Factory Assigned

0 = Standard

Electrical Options

A = None (n/a on 29 size)
 C = Non-Fused Disconnect (n/a on 29 size)
 G = 2-Speed Indoor Fan (VFD) Controller (Standard on 29 size models)
 J = 2 Speed Fan Controller (VFD) and Non-Fused Disconnect

Service Options

0 = None
 1 = Unpowered Convenience Outlet
 2 = Powered Convenience Outlet
 3 = Hinged Panels
 4 = Hinged Panels and Unpowered Convenience Outlet
 5 = Hinged Panels and Powered Convenience Outlet

Intake / Exhaust Options

A = None
 B = Temperature Economizer w/ Barometric Relief
 F = Enthalpy Economizer w/ Barometric Relief
 K = 2-Position Damper
 U = Temp Ultra Low Leak Economizer w/ Baro Relief
 W = Enthalpy Ultra Low Leak Economizer w/ Baro Relief

Base Unit Controls

0 = Electro mechanical controls. Can be used with W7212 EconoMi\$er IV (Non-Fault Detection and Diagnostic)
 1 = PremierLink Controller
 2 = RTU Open Multi-Protocol Controller
 6 = Electro mechanical controls. Can be used with W7220 EconoMi\$er X (with Fault Detection and Diagnostic)

Design Revision

- = Factory Design Revision

Voltage

1 = 575/3/60
 5 = 208-230/3/60
 6 = 460/3/60

Fig. 1 - 48TC Horizontal Airflow Units Model Number Nomenclature (Example)

C13786B

Table 1 – FACTORY-INSTALLED OPTIONS AND FIELD-INSTALLED ACCESSORIES

CATEGORY	ITEM	FACTORY INSTALLED OPTION	FIELD INSTALLED ACCESSORY
Cabinet	Hinged Access Panels	X	
Coil Options	Cu/Cu outdoor & indoor coils	X	
	E-coated outdoor & indoor coils	X	
	Pre-coated outdoor coils	X	
Humidity Control	Humidi-MiZer Adaptive Dehumidification System	X	
Condenser Protection	Condenser coil hail guard (louvered design)	X	X
Controls	Thermostats, temperature sensors, and subbases		X
	PremierLink DDC communicating controller	X	X
	RTU Open protocol controller	X	
	Smoke detector (supply and/or return air)	X	X
	Time Guard II compressor delay control circuit		X
	Phase Monitor		X
	Carrier Energy Demand System (EDS)		X
Economizers & Outdoor Air Dampers	EconoMiSer IV for electro-mechanical controls Non FDD (Standard air leak damper models) ⁵	X	X
	EconoMiSer2 for DDC controls, complies with FDD (Standard and Ultra Low Leak air damper models) ^{5,6}	X	X
	Motorized 2 position outdoor-air damper	X	X
	Manual outdoor-air damper (25%)	X	X
	Barometric relief ¹	X	X
	Barometric hood (Horizontal economizer)		X
	Power exhaust-centrifugal blower		X
Ultra Low Leak EconoMiSer X for electro-mechanical controls, complies with FDD. (Standard and Ultra Low Leak air damper models) ⁵	X	X	
Economizer Sensors & IAQ Devices	Single dry bulb temperature sensors ²	X	X
	Differential dry bulb temperature sensors ²		X
	Single enthalpy sensors ²	X	X
	Differential enthalpy sensors ²		X
	Wall or duct mounted CO ₂ sensor ²		X
	Unit mounted CO ₂ sensor ²	X	
	4-in Filter Track Assembly		X
Gas Heat	Propane conversion kit		X
	Stainless steel heat exchanger	X	
	High altitude conversion kit		X
	Flue Discharge Deflector		X
Indoor Motor & Drive	Multiple motor and drive packages	X	
	Staged Air Vol (SAV) system w/VFD controller (2-stage cool only with electrical mechanical and RTU Open controls)	X	
	Display Kit for SAV system with VFD		X
Low Ambient Control	Winter start kit ²		X
	Motormaster head pressure controller to -20°F (-29°C) ³		X
Power Options	Convenience outlet (powered)	X	
	Convenience outlet (unpowered)	X	
	Non-fused disconnect ⁴	X	
Roof Curbs	Roof curb 14-in (356mm)		X
	Roof curb 24-in (610mm)		X

NOTES:

- Included with economizer.
- Sensors used to optimize economizer performance.
- See application data for assistance.
- Non-fused disconnect switch cannot be used when unit FLA rating exceeds 200 amps on 208/230 volt and 100 amps on 460/575 volt units. Carrier Packaged RTUBuilder selects this automatically.
- FDD (Fault Detection and Diagnostic) capability per California Title 24 section 120.2.
- Models with RTU Open DDC controls comply with California Title 24 Fault Detection and Diagnostic (FDD). PremierLink is non FDD.

FACTORY OPTIONS AND/OR ACCESSORIES

Economizer (dry-bulb or enthalpy)

Economizers save energy, money and improve comfort levels in the conditioned space. They bring in fresh, outside air for ventilation; and provide cool outside air to cool your building. This also is the preferred method of low ambient cooling. When integrated with CO₂ sensors, economizers can provide even more savings by coupling the ventilation air to only that amount required based on space occupancy. Economizers are available, installed and tested by the factory, with either enthalpy or temperature dry-bulb inputs. There are also models for electromechanical, direct digital controllers and single speed fan or 2-speed indoor fan motors. Additional sensors are available as accessories to optimize the economizer. Economizers include gravity controlled barometric relief that helps equalize building pressure and ambient air pressures. This can be a cost effective solution to prevent building pressurization. Economizers are available in Ultra Low Leak and standard low leak versions.

CO₂ Sensor

Improves productivity and saves money by working with the economizer to intake only the correct amount of outside air for ventilation. As occupants fill your building, the CO₂ sensor detects their presence through increasing CO₂ levels, and opens the economizer appropriately.

When the occupants leave, the CO₂ levels decrease, and the sensor appropriately closes the economizer. This intelligent control of the ventilation air, called Demand Control Ventilation (DCV) reduces the overall load on the rooftop, saving money.

Smoke Detectors

Trust the experts. Smoke detectors make your application safer and your job easier. Carrier smoke detectors immediately shut down the rooftop unit when smoke is detected. They are available, installed by the factory, for supply air, return air, or both.

Louvered Hail Guards

Sleek, louvered panels protect the condenser coil from hail damage, foreign objects, and incidental contact.

Convenience Outlet (powered or un-powered)

Reduce service and/or installation costs by including a convenience outlet in your specification. Carrier will install this service feature at our factory. Provides a convenient, 15 amp, 115v GFCI receptacle with “Wet in Use” cover. The “powered” option allows the installer to power the outlet from the line side of the disconnect side as required by code. The “unpowered” option is to be powered from a separate 115/120v power source.

Non-Fused Disconnect

This OSHA-compliant, factory-installed, safety switch allows a service technician to locally secure power to the rooftop.

Power Exhaust with Barometric Relief

Superior internal building pressure control. This field-installed accessory or factory-installed option may eliminate the need for costly, external pressure control fans.

PremierLink, DDC Controller

This CCN controller regulates your rooftop’s performance to tighter tolerances and expanded limits, as well as facilitates zoning systems and digital accessories. It also unites your Carrier HVAC equipment together on one, coherent CCN network. The PremierLink can be factory-installed, or easily field-installed.

RTU Open Protocol Controller

Connect the rooftop to an existing BAS without needing complicated translators or adapter modules using the RTU Open controller. This new controller speaks the 4 most common building automation system languages (Bacnet, Modbus, N2, and Lonworks). Use this controller when you have an existing BAS.

Time Guard II Control Circuit

This accessory protects your compressor by preventing short-cycling in the event of some other failure, prevents the compressor from restarting for 30 seconds after stopping. Not required with PremierLink, RTU Open, or authorized commercial thermostats.

Motorized 2-Position Damper

The new Carrier 2-position, motorized outdoor air damper admits up to 100% outside air. Using reliable, gear-driven technology, the 2-position damper opens to allow ventilation air and closes when the rooftop stops, stopping unwanted infiltration.

Manual OA Damper

Manual outdoor air dampers are an economical way to bring in ventilation air. The dampers are available in 25% versions.

Optional Humidi-MiZer Adaptive Dehumidification System

Carrier’s Humidi-MiZer adaptive dehumidification system is an all-inclusive factory installed option that can be ordered with any WeatherMaker 48TC18-29 rooftop unit.

This system expands the envelope of operation of Carrier’s WeatherMaker rooftop products to provide unprecedented flexibility to meet year round comfort conditions.

The Humidi-MiZer adaptive dehumidification system has the industry’s only dual dehumidification mode setting. The Humidi-MiZer system includes two new modes of operation.

FACTORY OPTIONS AND/OR ACCESSORIES (cont.)

Optional Humidi-MiZer Adaptive Dehumidification System (cont.)

The WeatherMaker 48TC18-29 rooftop coupled with the Humidi-MiZer system is capable of operating in normal design cooling mode, subcooling mode, and hot gas reheat mode. Normal design cooling mode is when the unit will operate under its normal sequence of operation by cycling compressors to maintain comfort conditions.

Subcooling mode will operate to satisfy part load type conditions when the space requires combined sensible and a higher proportion of latent load control. Hot Gas Reheat mode will operate when outdoor temperatures diminish and the need for latent capacity is required for sole humidity control. Hot Gas Reheat mode will provide neutral air for maximum dehumidification operation.

Staged Air Volume (SAV) Indoor Fan Speed System

Carrier's Staged Air Volume (SAV) system saves energy and installation time by utilizing a Variable Frequency Drive (VFD) to automatically adjust the indoor fan motor speed in sequence with the units cooling operation. Per ASHRAE 90.1 2010 standard section 6.4.3.10.b, during the first stage of cooling operation the VFD will adjust the fan motor to provide 2/3rd of the total cfm established for the unit. When a call for the second stage of cooling is required, the VFD will allow the total cfm for the unit established (100%). During the heating mode the VFD will allow total design cfm (100%) operation and during the ventilation mode the VFD will allow operation to 2/3rd of total cfm.

Compared to single speed indoor fan motor systems, Carrier's SAV system can save substantial energy, 25%+*, versus single speed indoor fan motor systems.

The VFD used in Carrier's SAV system has soft start capabilities to slowly ramp up the speeds, thus eliminating any high inrush air volume during initial start-up. It also has internal over current protection for the fan motor and a field installed display kit that allows adjustment and in depth diagnostics of the VFD.

This SAV system is available on models with 2-stage cooling operation with electrical mechanical or RTU Open, Multi Protocol controls. Both space sensor and conventional thermostats controls can be used to provide accurate control in any application.

The SAV system is very flexible for initial fan performance set up and adjustment. The standard factory shipped VFD is pre-programmed to automatically stage the fan speed between the first and second stage of cooling. The unit fan performance static pressure and cfm can be easily adjusted using the traditional means of pulley adjustments. The other means to adjust the unit static and cfm performance is to utilize the field installed Display Kit and adjust the frequency and voltage in the VFD to required performance requirements. In either case,

once set up, the VFD will automatically adjust the speed between the cooling stage operations.

*Data based on .10 (\$/kWh) in an office application utilizing Carrier's HAP 4.6 simulation software program.

MotorMaster Head Pressure Controller

The MotorMaster motor controller is a low ambient, head pressure controller kit that is designed to maintain the unit's condenser head pressure during periods of low ambient cooling operation. This device should be used as an alternative to economizer free cooling not when economizer usage is either not appropriate or desired. The Motormaster will either cycle the outdoor-fan motors or operate them at reduced speed to maintain the unit operation, depending on the model.

MotorMaster allows cooling operation down to -20°F (-29°C) ambient conditions.

Winter Start Kit

The winter start kit by Carrier extends the low ambient limit of your rooftop to 25°F (-4°C). The kit bypasses the low pressure switch, preventing nuisance tripping of the low pressure switch. Other low ambient precautions may still be prudent.

Propane Heating

Convert your gas heat rooftop from standard natural gas operation to Propane using this field-installed kit.

High Altitude Heating

High altitudes have less oxygen, which means heat exchangers need less fuel. The new gas orifices in this field-installed kit make the necessary adjustment for high altitude applications. They restore the optimal fuel to air mixture and maintain healthy combustion at altitudes above 2000 ft (610m). Kits may not be required in all areas.

Optional Stainless Steel Heat Exchanger

The stainless steel heat exchanger option provides the tubular heat exchanger be made out of a minimum 20 gauge type 409 stainless steel for applications where the mixed air to the heat exchanger is expected to drop below 45°F (7°C). Stainless steel may be specified on applications where the presence of airborne contaminants require its use (applications such as paper mills) or in area with very high outdoor humidity that may result in severe condensation in the heat exchanger during cooling operation.

Flue Discharge Deflector

The flue discharge deflector is a useful accessory when flue gas recirculation is a concern. By venting the flue discharge upwards, the deflector minimizes the chance for a neighboring unit to intake the flue exhaust.

FACTORY OPTIONS AND/OR ACCESSORIES (cont.)

Alternate Motors and Drives

Some applications need larger horsepower motors, some need more airflow, and some need both. Regardless of the case, your Carrier expert has a factory installed combination to meet your application. A wide selection of motors and pulleys (drives) are available, factory installed, to handle nearly any application.

Thru-the-Base Connections

Thru-the-base provisions/connection points are available as standard with every unit. When bottom connections are required, field furnished couplings are required.

Barometric Hood

For Horizontal Economizer applications where relief damper is installed in duct work. This kit provides the needed protection.

Hinged Access Panels

Allows access to unit's major components with specifically designed hinged access panels. Panels are filter, control box, indoor fan motor.

Carrier Energy Demand System(EDS)

Carrier's wireless automated demand management and demand response controllers can be easily installed onto any packaged rooftop unit. Once installed, the controllers work together like a swarm of bees, intelligently communicating and managing the duty cycles of the units being controlled.

Utilizing patented intelligence, the controllers dramatically reduce peak electrical demand by up to 30 percent in commercial and light industrial properties and allow for effective scheduling of overnight and weekend loads. This platform can easily be installed when a full building automation system is not required.

The Energy Demand System is as easy to install as thermostats, and requires no special training. Every controller has a built-in self-configuring wireless network. The controllers work together to establish a wireless network, eliminating the need for expensive wiring. The secure web portal allows property managers to easily access multiple sites from any internet connection to monitor building performance and reconfigure controllers for demand response or the scheduling of loads.

- Simple, affordable, wireless electrical demand management
- Automated demand response, including Open ADR
- Energy consumption reduction through efficient schedule-based control
- Intelligent, adaptive energy management
- Web-based interface
- Electrical demand reductions
- Reduce energy costs, not comfort

Table 2 – AHRI COOLING RATING TABLE

2-STAGE COOLING

UNIT	COOLING STAGES	NOM. CAPACITY (TONS)	NET COOLING CAPACITY (MBH)	TOTAL POWER (kW)	EER	IEER WITH SINGLE SPEED INDOOR FAN MOTOR	IEER WITH 2-SPEED INDOOR FAN MOTOR
18	2	15	172.0	15.9	10.8	11.0	12.7
21	2	17.5	200.0	18.5	10.8	11.0	12.7
25	2	20	232.0	21.5	10.8	11.0	12.4
29	2	25	280.0	28.6	9.8	N/A*	11.0

LEGEND

- AHRI – Air Conditioning, Heating and Refrigeration Institute Test Standard
- ASHRAE – American Society of Heating, Refrigerating and Air Conditioning, Inc.
- EER – Energy Efficiency Ratio
- IEER – Integrated Energy Efficiency Ratio
- * – Model only available with 2-Speed indoor Fan Motor

NOTES:

1. Rated and certified under AHRI Standard 340/360, as appropriate.
2. Ratings are based on:
Cooling Standard: 80°F (27°C) db, 67°F (19°C) wb indoor air temp and 95°F (35°C) db outdoor air temp.
IEER Standard: A measure that expresses cooling part-load EER efficiency for commercial unitary air conditioning and heat pump equipment on the basis of weighted operation at various load capacities.
3. All 48TC units comply with ASHRAE 90.1 Energy Standard for minimum EER and IEER requirements.
4. 48TC units comply with US Energy Policy Act (2005). To evaluate code compliance requirements, refer to state and local codes or visit the following website: <http://bcap-energy.org> to determine if compliance with this standard pertains to your state, territory, or municipality.



Use of the AHRI Certified TM Mark indicates a manufacturer's participation in the program. For verification of certification for individual products, go to www.ahridirectory.org.



Table 3 – HEATING RATING TABLE - NATURAL GAS & PROPANE

MODEL SIZE	HEAT SIZE	AL/SS HEAT EXCHANGER		TEMP RISE (DEG F)	THERMAL EFFICIENCY (%)
		INPUT / OUTPUT STAGE 2 (MBH)	INPUT / OUTPUT STAGE 1 (MBH)		
18	LOW	220 / 178	176 / 142	20 – 55	81%
	MED	310 / 251	248 / 200	30 – 60	81%
	HIGH	400 / 324	320 / 260	35 – 65	81%
21	LOW	220 / 178	176 / 142	15 – 55	81%
	MED	310 / 251	248 / 200	25 – 60	81%
	HIGH	400 / 324	320 / 260	30 – 65	81%
25	LOW	220 / 178	176 / 142	15 – 55	81%
	MED	310 / 251	248 / 200	20 – 60	81%
	HIGH	400 / 324	320 / 260	30 – 65	81%
29	LOW	220 / 178	176 / 142	10 – 55	81%
	MED	310 / 251	248 / 200	15 – 60	81%
	HIGH	400 / 324	320 / 260	20 – 65	81%

NOTES:

- Heat ratings are for natural gas heat exchangers operated at or below 2000 ft (610 m). For information on Propane or altitudes above 2000 ft (610 m), see the Application Data section of this book. Accessory Propane/High Altitude kits are also available.
- In the USA the input rating for altitudes above 2000 ft (610m) must be derated by 4% for each 1000 ft (305 m) above sea level. In Canada, the input rating must be derated by 10% for altitudes of 2000 ft (610 m) to 4500 ft (1372 m) above sea level.

Table 4 – SOUND PERFORMANCE TABLE

MODE SIZE	CLG STAGES	OUTDOOR SOUND (dB)									
		A-Wgt	AHRI 370 Rating	63	125	250	500	1000	2000	4000	8000
18	2	84.1	84	92.2	83.9	80.4	81.8	78.7	76.5	72.2	65.4
21	2	84.1	84	92.2	83.9	80.4	81.8	78.7	76.5	72.2	65.4
25	2	86.5	87	95.6	87.5	84.2	84.2	81.7	77.9	73.2	66.3
29	2	85.9	86	97.1	88.3	84.4	83.3	80.7	77.4	73.4	67.3

LEGEND

dB – Decibel

NOTES:

1. Outdoor sound data is measure in accordance with AHRI standard 270–2008.
2. Measurements are expressed in terms of sound power. Do not compare these values to sound pressure values because sound pressure depends on specific environmental factors which normally do not match individual applications. Sound power values are independent of the environment and therefore more accurate.
3. A-weighted sound ratings filter out very high and very low frequencies, to better approximate the response of “average” human ear. A-weighted measurements for Carrier units are taken in accordance with AHRI standard 270–2008.



Table 5 – MINIMUM - MAXIMUM AIRFLOW RATINGS - NATURAL GAS & PROPANE

Unit	Heat Level	Cooling				AL HX Heating		SS HX Heating	
		Minimum Single Spd Fan Motor	Minimum 2–Spd Fan Motor (High Spd)	Minimum 2–Spd Fan Motor (Low Spd)	Maximum	Minimum	Maximum	Minimum	Maximum
18	LOW	4500	5070	3346	7500	3000	8250	3000	8250
	MED					3880	7750	3880	7750
	HIGH					4620	8570	4620	8570
21	LOW	5250	5915	3904	9000	3000	11000	3000	11000
	MED					3880	9300	3880	9300
	HIGH					4620	10000	4620	10000
25	LOW	6000	7500	4950	10000	3000	11000	3000	11000
	MED					3880	11630	3880	11630
	HIGH					4620	10000	4620	10000
29	LOW	7500	8450	5577	12500	3000	16500	3000	16500
	MED					3880	15500	3880	15500
	HIGH					4620	15000	4620	15000

AL = Aluminum Gas Heat Exchanger

SS = Stainless Steel Gas Heat Exchanger

**Table 6 – PHYSICAL DATA (COOLING)
RTPF - ROUND TUBE/PLATE FIN COIL DESIGN**

15 - 25 TONS

		48TC*D18	48TC*E18	48TC*D21	48TC*E21
Refrigeration System					
	# Circuits / # Comp. / Type	2 / 2 / Scroll	2 / 2 / Scroll	2 / 2 / Scroll	2 / 2 / Scroll
	R-410a charge A/B (lbs)	17/16.4	24.5/25.7	17.5/16.8	25.5/25.5
	Metering device	TXV	TXV	TXV	TXV
	High–press. Trip / Reset (psig)	630 / 505	630 / 505	630 / 505	630 / 505
	Low–press. Trip / Reset (psig)	54 / 117	27 / 44	54 / 117	27 / 44
Evap. Coil					
	Material	Cu / Al	Cu / Al	Cu / Al	Cu / Al
	Tube Diameter	3/8" RTPF	3/8" RTPF	3/8" RTPF	3/8" RTPF
	Rows / FPI	4 / 15	4 / 15	4 / 15	4 / 15
	total face area (ft ²)	22	22	22	22
	Condensate drain conn. size	3/4"	3/4"	3/4"	3/4"
Humidimizer Coil					
	Material	n/a	Cu / Al	n/a	Cu / Al
	Tube Diameter	n/a	3/8" RTPF	n/a	3/8" RTPF
	Rows / FPI	n/a	1 / 17	n/a	1 / 17
	total face area (ft ²)	n/a	22	n/a	22
Evap. fan and motor					
HORIZONTAL					
Standard Static	Motor Qty / Belt Qty / Driver Type	1/1/Belt	1/1/Belt	1/1/Belt	1/1/Belt
	Max BHP	2.2	2.2	3.3	3.3
	RPM range	514–680	514–680	622–822	622–822
	motor frame size	56	56	56	56
	Fan Qty / Type	2 / Centrifugal	2 / Centrifugal	2 / Centrifugal	2 / Centrifugal
	Fan Diameter (in)	18 x 15/15 X 11	18 x 15/15 X 11	18 x 15/15 X 11	18 x 15/15 X 11
Medium Static	Motor Qty / Belt Qty / Driver Type	1/1/Belt	1/1/Belt	1/1/Belt	1/1/Belt
	Max BHP	3.3	3.3	4.9	4.9
	RPM range	614–780	614–780	713–879	713–879
	motor frame size	56	56	56	56
	Fan Qty / Type	2 / Centrifugal	2 / Centrifugal	2 / Centrifugal	2 / Centrifugal
	Fan Diameter (in)	18 x 15/15 X 11	18 x 15/15 X 11	18 x 15/15 X 11	18 x 15/15 X 11
High Static	Motor Qty / Belt Qty / Driver Type	1/1/Belt	1/1/Belt	n/a	n/a
	Max BHP	4.9	4.9	n/a	n/a
	RPM range	746–912	746–912	n/a	n/a
	motor frame size	56	56	n/a	n/a
	Fan Qty / Type	2 / Centrifugal	2 / Centrifugal	n/a	n/a
	Fan Diameter (in)	18 x 15/15 X 11	18 x 15/15 X 11	n/a	n/a
High Static – High Eff.	Motor Qty / Belt Qty / Driver Type	n/a	n/a	1/1/Belt	1/1/Belt
	Max BHP	n/a	n/a	6.5/ 6.9/ 7.0/ 8.3	6.5/ 6.9/ 7.0/ 8.3
	RPM range	n/a	n/a	882–1078	882–1078
	motor frame size	n/a	n/a	184T	184T
	Fan Qty / Type	n/a	n/a	2 / Centrifugal	2 / Centrifugal
	Fan Diameter (in)	n/a	n/a	18 x 15/15 X 11	18 x 15/15 X 11

**Table 6 (cont.) - PHYSICAL DATA (COOLING)
RTPF - ROUND TUBE/PLATE FIN COIL DESIGN**

15 - 25 TONS

		48TC*D25	48TC*E25	48TC*D29	48TC*E29
Refrigeration System					
# Circuits / # Comp. / Type		2 / 2 / Scroll	2 / 2 / Scroll	2 / 2 / Scroll	2 / 2 / Scroll
R-410a charge A/B (lbs)		23.8/23.1	30.0/30.7	24.9/27.7	35.1/35.4
Metering device		TXV	TXV	TXV	TXV
High-press. Trip / Reset (psig)		630 / 505	630 / 505	630 / 505	630 / 505
Low-press. Trip / Reset (psig)		54 / 117	27 / 44	54 / 117	27 / 44
Evap. Coil					
Material		Cu / Al	Cu / Al	Cu / Al	Cu / Al
Tube Diameter		3/8" RTPF	3/8" RTPF	3/8" RTPF	3/8" RTPF
Rows / FPI		4 / 15	4 / 15	4 / 15	4 / 15
total face area (ft ²)		26	26	26	26
Condensate drain conn. size		3/4"	3/4"	3/4"	3/4"
Humidimizer Coil					
Material		n/a	Cu / Al	n/a	Cu / Al
Tube Diameter		n/a	3/8" RTPF	n/a	3/8" RTPF
Rows / FPI		n/a	1 / 17	n/a	1 / 17
total face area (ft ²)		n/a	26	n/a	26
Evap. fan and motor					
HORIZONTAL					
Standard Static	Motor Qty / Belt Qty / Driver Type	1/1/Belt	1/1/Belt	n/a	n/a
	Max BHP	4.9	4.9	n/a	n/a
	RPM range	690-863	690-863	n/a	n/a
	motor frame size	56	56	n/a	n/a
	Fan Qty / Type	2 / Centrifugal	2 / Centrifugal	n/a	n/a
	Fan Diameter (in)	18 x 15/15 X 11	18 x 15/15 X 11	n/a	n/a
Medium Static - High Eff.	Motor Qty / Belt Qty / Driver Type	1/1/Belt	1/1/Belt	1/1/Belt	1/1/Belt
	Max BHP	6.5/ 6.9/ 7.0/ 8.3	6.5/ 6.9/ 7.0/ 8.3	6.5/ 6.9/ 7.0/ 8.3	6.5/ 6.9/ 7.0/ 8.3
	RPM range	835-1021	835-1021	755-923	755-923
	motor frame size	184T	184T	184T	184T
	Fan Qty / Type	2 / Centrifugal	2 / Centrifugal	2 / Centrifugal	2 / Centrifugal
	Fan Diameter (in)	18 x 15/15 X 11	18 x 15/15 X 11	18 x 15/15 X 11	18 x 15/15 X 11
High Static - High Eff.	Motor Qty / Belt Qty / Driver Type	1/1/Belt	1/1/Belt	1/1/Belt	1/1/Belt
	Max BHP	10.5/11.9/11.9/11	10.5/11.9/11.9/11	10.5/11.9/11.9/11	10.5/11.9/11.9/11
	RPM range	941-1176	941-1176	827-1010	827-1010
	motor frame size	213T	213T	213T	213T
	Fan Qty / Type	2 / Centrifugal	2 / Centrifugal	2 / Centrifugal	2 / Centrifugal
	Fan Diameter (in)	18 x 15/15 X 11	18 x 15/15 X 11	18 x 15/15 X 11	18 x 15/15 X 11

Table 6 (cont.) - PHYSICAL DATA (COOLING)
RTPF - ROUND TUBE/PLATE FIN COIL DESIGN

15 - 25 TONS

	48TC*D18	48TC*E18	48TC*D21	48TC*E21	48TC*D25	48TC*E25	48TC*D29	48TC*E29
Cond. Coil (Circuit A)								
Coil type	RTPF	RTPF	RTPF	RTPF	RTPF	RTPF	RTPF	RTPF
Coil Length (in)	70	70	72	72	82	82	95	95
Coil Height (in)	44	44	44	44	52	52	52	52
Rows / FPI	2 /17	2 /17	2 /17	2 /17	2 /17	2 /17	2 /17	2 /17
total face area (ft2)	21.4	21.4	22.0	22.0	29.6	29.6	34.3	34.3
Cond. Coil (Circuit B)								
Coil type	RTPF	RTPF	RTPF	RTPF	RTPF	RTPF	RTPF	RTPF
Coil Length (in)	70	70	64	64	80	80	95	95
Coil Height (in)	44	44	44	44	52	52	52	52
Rows / FPI	2 /17	2 /17	2 /17	2 /17	2 /17	2 /17	2 /17	2 /17
total face area (ft2)	21.4	21.4	19.5	19.5	29.6	29.6	34.3	34.3
Cond. fan / motor								
Qty / Motor drive type	3 / direct	3 / direct	4 / direct	4 / direct	4 / direct	4 / direct	6 / direct	6 / direct
Motor HP / RPM	1/4 / 1100	1/4 / 1100	1/4 / 1100	1/4 / 1100	1/4 / 1100	1/4 / 1100	1/4 / 1100	1/4 / 1100
Fan diameter (in)	22	22	22	22	22	22	22	22
Filters								
RA Filter # / size (in)	6 / 20 x 25 x 2	6 / 20 x 25 x 2	6 / 20 x 25 x 2	6 / 20 x 25 x 2	9 / 16 x 25 x 2	9 / 16 x 25 x 2	9 / 16 x 25 x 2	9 / 16 x 25 x 2
OA inlet screen # / size (in)	4 / 16 x 25 x 1	4 / 16 x 25 x 1	4 / 16 x 25 x 1	4 / 16 x 25 x 1	4 / 16 x 25 x 1	4 / 16 x 25 x 1	4 / 16 x 25 x 1	4 / 16 x 25 x 1

Table 7 – PHYSICAL DATA (HEATING)

15 - 25 TONS

		48TC**18	48TC**21	48TC**25	48TC**29
Gas Connection					
	# of Gas Valves	1	1	1	1
	Nat. gas supply line press (in. w.g.) / (PSIG)	5 – 13 / 0.18–0.47	5 – 13 / 0.18–0.47	5 – 13 / 0.18–0.47	5 – 13 / 0.18–0.47
	LP supply line press (in. w.g.) / (PSIG)	11–13 / 0.40–0.47	11–13 / 0.40–0.47	11–13 / 0.40–0.47	11–13 / 0.40–0.47
Heat Anticipator setting (Amps)					
	1st stage	0.14	0.14	0.14	0.14
	2nd stage	0.14	0.14	0.14	0.14
Natural Gas Heat					
LOW	# of stages / # of burners (total)	2 / 5	2 / 5	2 / 5	2 / 5
	Connection Size	3/4" NPT	3/4" NPT	3/4" NPT	3/4" NPT
	Rollout switch opens / closes	195 / 115	195 / 115	195 / 115	195 / 115
	Temperature Rise	25 – 55	25 – 55	25 – 55	25 – 55
MED	# of stages / # of burners (total)	2 / 7	2 / 7	2 / 7	2 / 7
	Connection Size	3/4" NPT	3/4" NPT	3/4" NPT	3/4" NPT
	Rollout switch opens / closes	195 / 115	195 / 115	195 / 115	195 / 115
	Temperature Rise	30– 60	30– 60	30– 60	30– 60
HIGH	# of stages / # of burners (total)	2 / 10	2 / 10	2 / 10	2 / 10
	Connection Size	3/4" NPT	3/4" NPT	3/4" NPT	3/4" NPT
	Rollout switch opens / closes	195 / 115	195 / 115	195 / 115	195 / 115
	Temperature Rise	35– 65	35– 65	35– 65	35– 65
Liquid Propane Heat					
LOW	# of stages / # of burners (total)	2 / 5	2 / 5	2 / 5	2 / 5
	Connection Size	3/4" NPT	3/4" NPT	3/4" NPT	3/4" NPT
	Rollout switch opens / closes	195 / 115	195 / 115	195 / 115	195 / 115
	Temperature Rise	25 – 55	25 – 55	25 – 55	25 – 55
MED	# of stages / # of burners (total)	2 / 7	2 / 7	2 / 7	2 / 7
	Connection Size	3/4" NPT	3/4" NPT	3/4" NPT	3/4" NPT
	Rollout switch opens / closes	195 / 115	196 / 115	197 / 115	198 / 115
	Temperature Rise	30– 60	30– 60	30– 60	30– 60
HIGH	# of stages / # of burners (total)	2 / 10	2 / 10	2 / 10	2 / 10
	Connection Size	3/4" NPT	3/4" NPT	3/4" NPT	3/4" NPT
	Rollout switch opens / closes	195 / 115	195 / 115	195 / 115	195 / 115
	Temperature Rise	35– 65	35– 65	35– 65	35– 65

DIMENSIONS

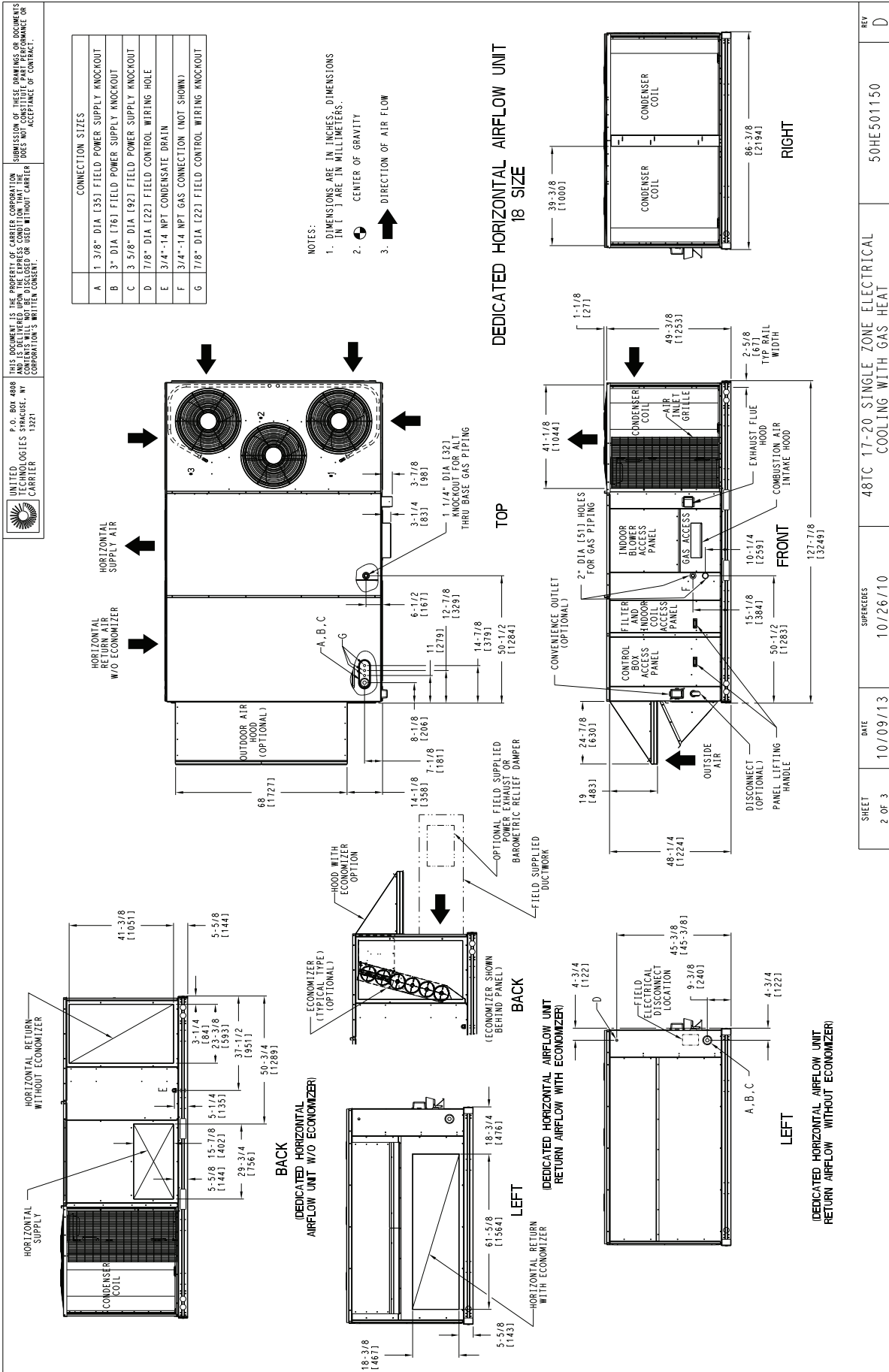

DIMENSIONS (cont.)



P. O. BOX 4888
UNITED TECHNOLOGIES SYRACUSE, NY
CORPORATION 13221
CARRIER

THIS DOCUMENT IS THE PROPERTY OF CARRIER CORPORATION AND IS DELIVERED ON THE EXPRESS CONDITION THAT THE USER DOES NOT CONSTITUTE PART PERFORMANCE OR ACCEPTANCE OF CONTRACT.

THIS DOCUMENT IS THE PROPERTY OF CARRIER CORPORATION AND IS DELIVERED ON THE EXPRESS CONDITION THAT THE USER DOES NOT CONSTITUTE PART PERFORMANCE OR ACCEPTANCE OF CONTRACT.

UNIT	STD UNIT WEIGHT *		CORNER WEIGHT (A)		CORNER WEIGHT (B)		CORNER WEIGHT (C)		CORNER WEIGHT (D)		C. G.								
	LBS.	KG.	LBS.	KG.	LBS.	KG.	LBS.	KG.	LBS.	KG.	X	Y	Z						
48TC17	1824	829	434	197	443	210	479	218	469	213	44	3/4	[1137]	64	3/4	[1645]	16	1/2	[419]
48TC20	1839	836	437	199	447	203	483	219	472	215	44	3/4	[1137]	64	3/4	[1645]	16	1/2	[419]
48TC17	1907	867	438	199	519	236	515	234	435	198	42	29/32	[1090]	69	1/4	[1759]	16	1/2	[419]
48TC18	1892	860	401	182	449	204	565	257	505	230	48	[1219]	67	3/8	[1711]	16	1/2	[419]	
48TC20	1922	874	441	201	523	238	519	236	438	199	42	29/32	[1090]	69	1/4	[1759]	16	1/2	[419]

RTPF - ROUND TUBE, PLATE FIN (COPPER/ALUM)
MCHX - NOVIATION (ALUM/ALUM)

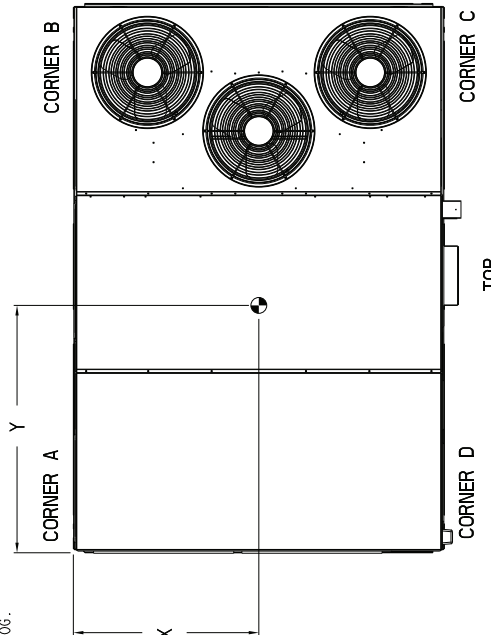

* STANDARD UNIT WEIGHT IS WITH LOW GAS HEAT AND WITHOUT PACKAGING.
FOR OTHER OPTIONS AND ACCESSORIES, REFER TO THE PRODUCT DATA CATALOG.

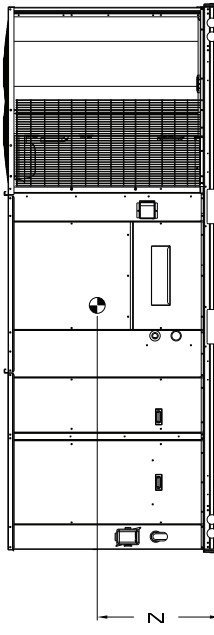

SHEET	DATE	SUPPLIERS	REV
3 OF 3	10/09/13	10/26/10	D

48TC 17-20 SINGLE ZONE ELECTRICAL COOLING WITH GAS HEAT

50HE501150

Fig. 2 - Unit Dimensional Drawing – 18 Size Unit (cont.)

DIMENSIONS (cont.)

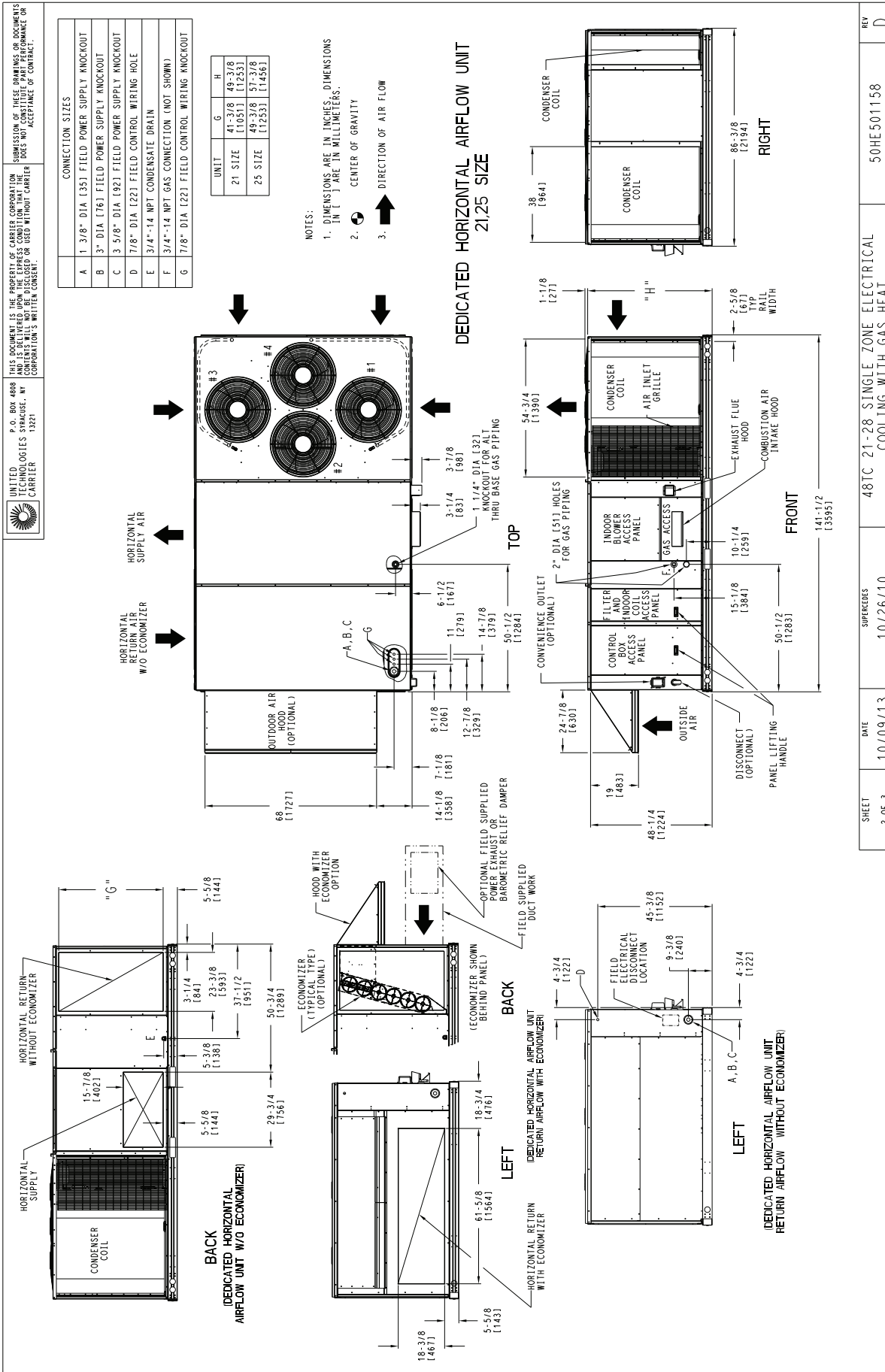
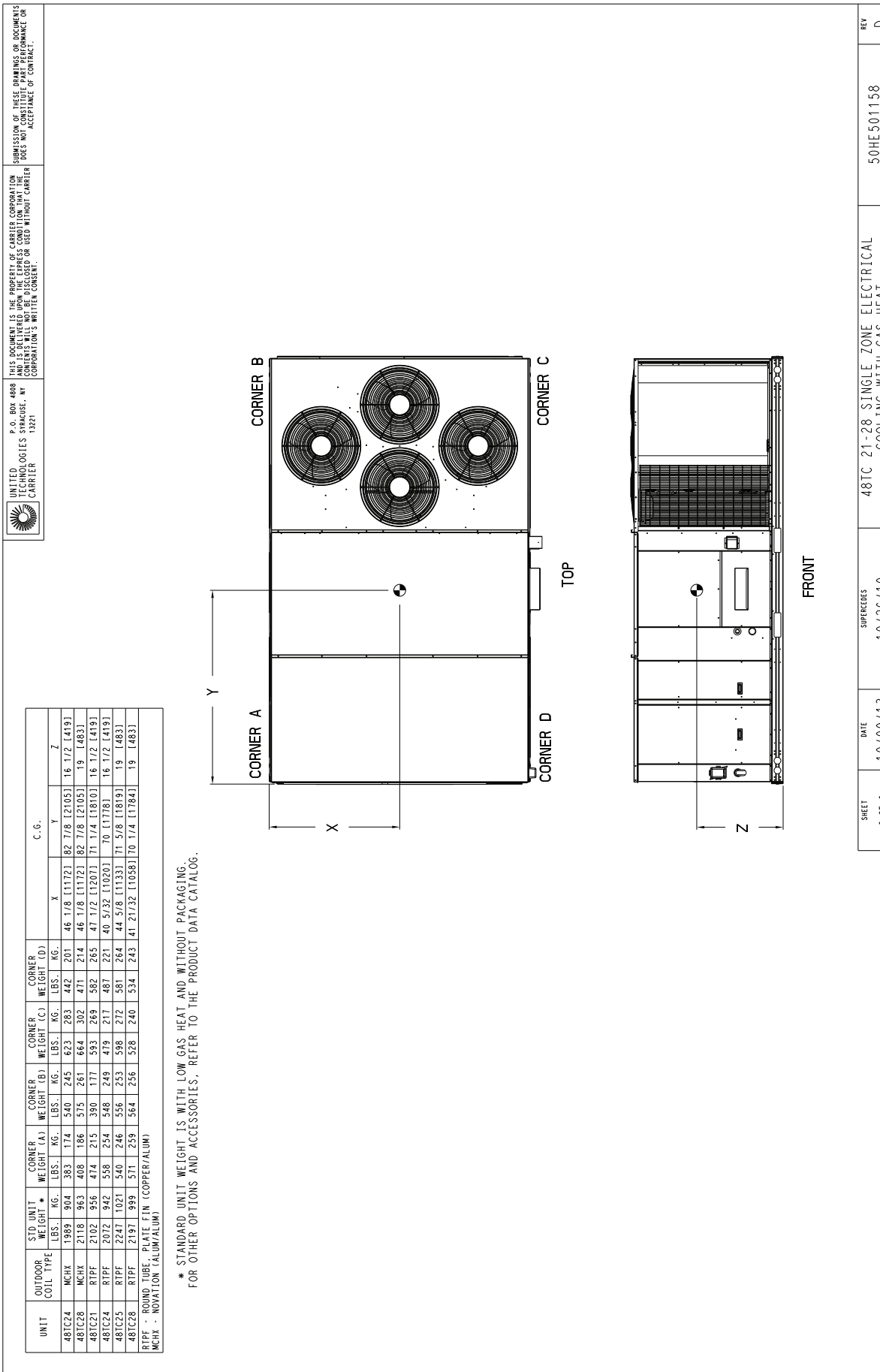

Fig. 3 - Unit Dimensional Drawing – 21 and 25 Size Units

DIMENSIONS (cont.)



SHEET 3 OF 3

DATE 10/09/13

SUPERSEDES 10/26/10

481C 21-28 SINGLE ZONE ELECTRICAL COOLING WITH GAS HEAT

50HE501158

REV D

Fig. 3 - Unit Dimensional Drawing – 21 and 25 Size Units (cont.)

DIMENSIONS (cont.)

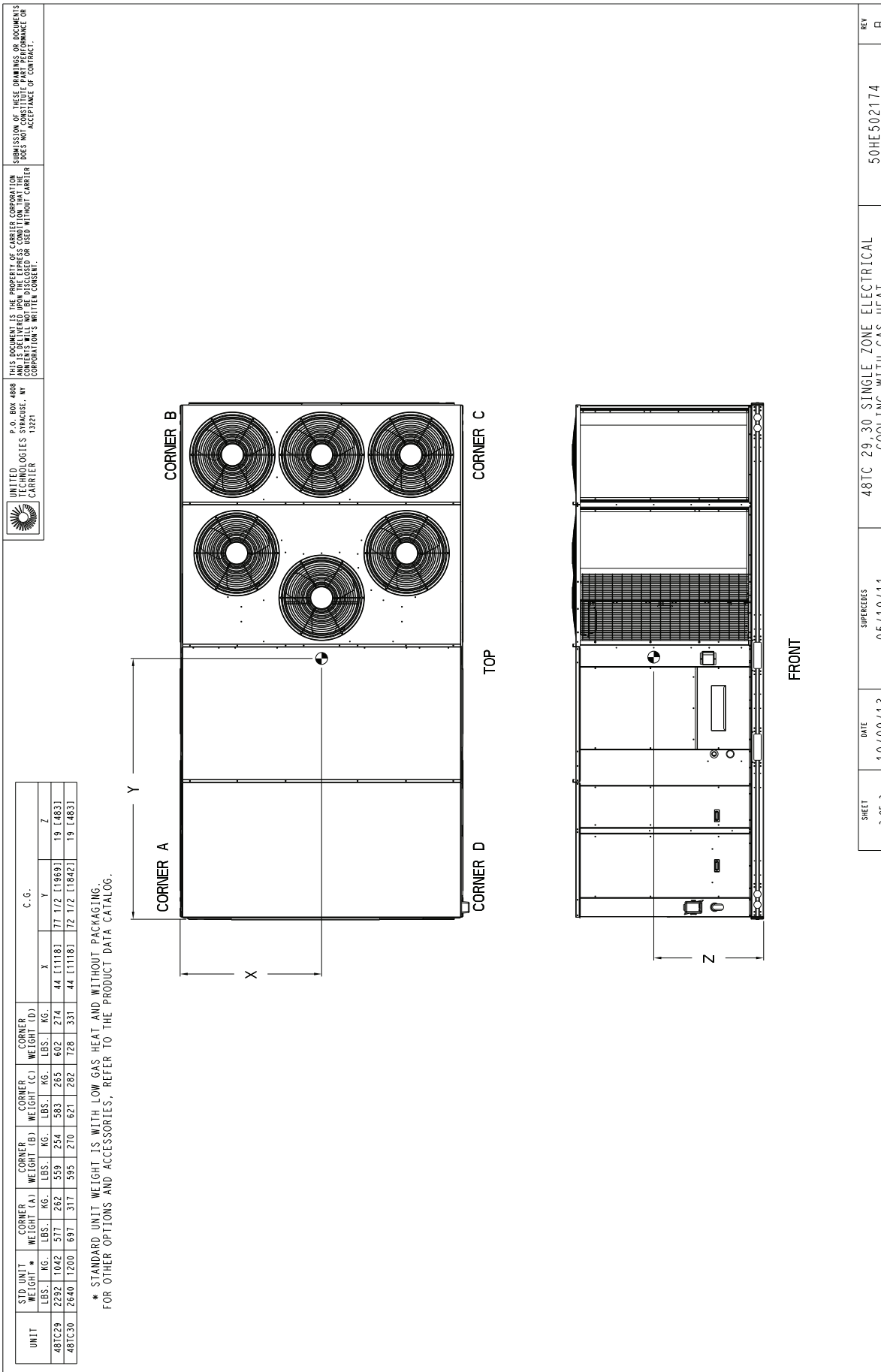
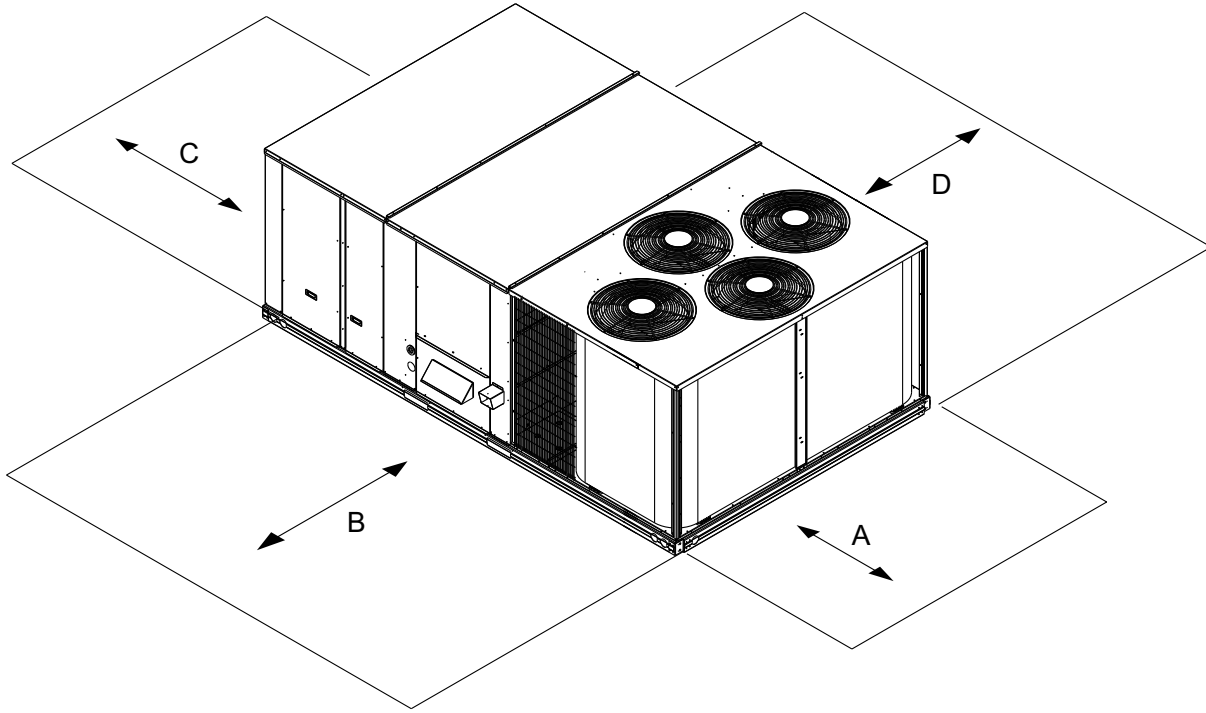

Fig. 4 - Unit Dimensional Drawing – 29 Size Unit (cont.)

DIMENSIONS (cont.)



C12384

LOCATION	DIMENSION	CONDITION
A	36-in (914 mm)	<ul style="list-style-type: none"> Recommended clearance for air flow and service
B	42-in (1067 mm)	<ul style="list-style-type: none"> Recommended clearance for air flow and service
C	18-in (457 mm)	<ul style="list-style-type: none"> No Convenience Outlet No Economizer No field installed disconnect on economizer hood side (Factory-installed disconnect installed).
	36-in (914 mm)	<ul style="list-style-type: none"> Convenience Outlet installed. Vertical surface behind servicer is electrically non-conductive (e.g.: wood, fiberglass).
	42-in (1067 mm)	<ul style="list-style-type: none"> Convenience Outlet installed. Vertical surface behind servicer is electrically conductive (e.g.: metal, masonry).
	96-in (2438 mm)	<ul style="list-style-type: none"> Economizer and/or Power Exhaust installed. Check for sources of flue products with 10 feet (3 meters) of economizer fresh air intake.
D	42-in (1067 mm)	<ul style="list-style-type: none"> Recommended clearance for service.

NOTE: Unit not designed to have overhead obstruction. Contact Application Engineering for guidance on any application planning overhead obstruction or for vertical clearances.

Fig. 5 - Service Clearance Dimensional Drawing

Table 8 – Operating Weights

48TC**	UNIT LB (KG)			
	18	21	25	29
Base Unit	1892 (858)	2102 (954)	2247 (1019)	2292 (1040)
Economizer	246 (112)	246 (112)	246 (112)	246 (112)
Powered Outlet	35 (16)	35 (16)	35 (16)	35 (16)
Humidi-MiZer [®] System	110 (50)	120 (54)	120 (54)	120 (54)
Curb				
14-in/356 mm	240 (109)	255 (116)	255 (116)	255 (116)
24-in/610 mm	340 (154)	355 (161)	355 (161)	355 (161)

DIMENSIONS (cont.)

UNIT SIZE	"A"	ROOF CURB ACCESSORY
18	1'-2" [356.0] 2'-0" [610.0]	CRRFCURB045A00 CRRFCURB046A00

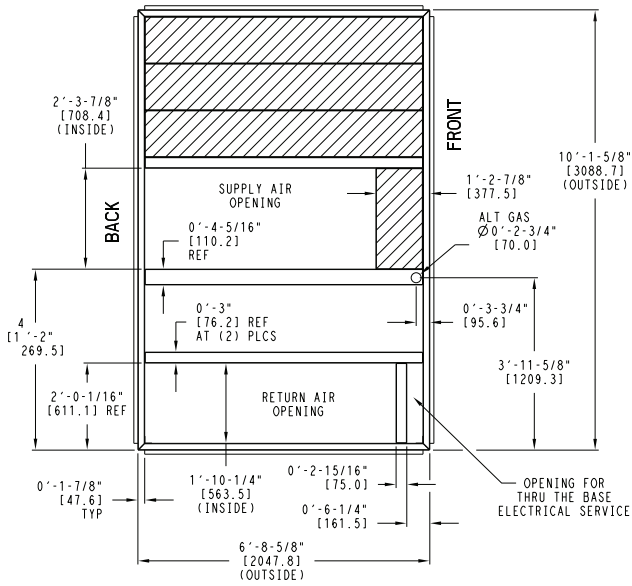

- NOTES:
- 1 ROOF CURB ACCESSORY IS SHIPPED UNASSEMBLED.
 - 2 DIMENSIONS IN () ARE IN MILLIMETERS.
 - 3 ROOF CURB GALVANIZED STEEL.
 - 4 ATTACH DUCTWORK TO CURB (FLANGES ON DUCT REST ON CURB)
 - 5 SERVICE CLEARANCE 4 FT ON EACH SIDE

➔ DIRECTION OF AIR FLOW

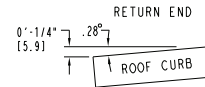
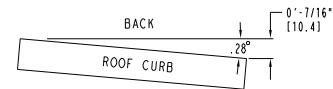

MAX CURB LEVELING TOLERANCES

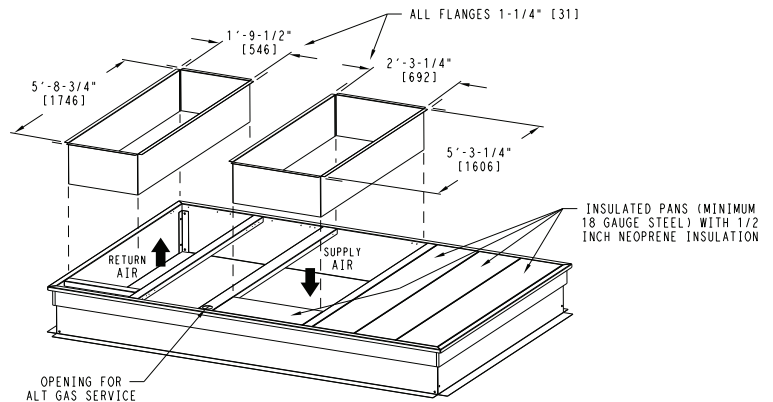
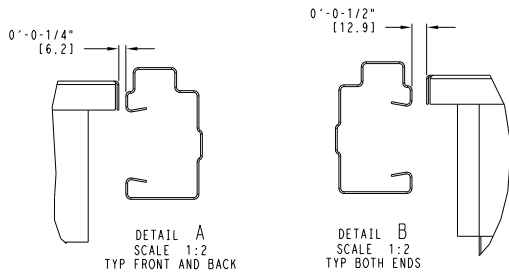
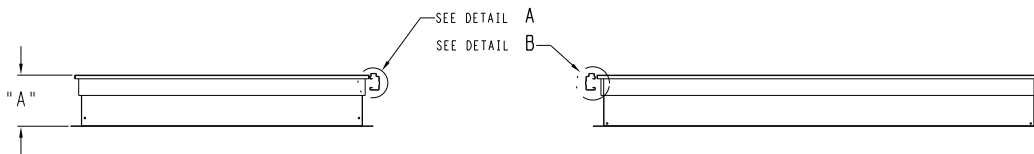
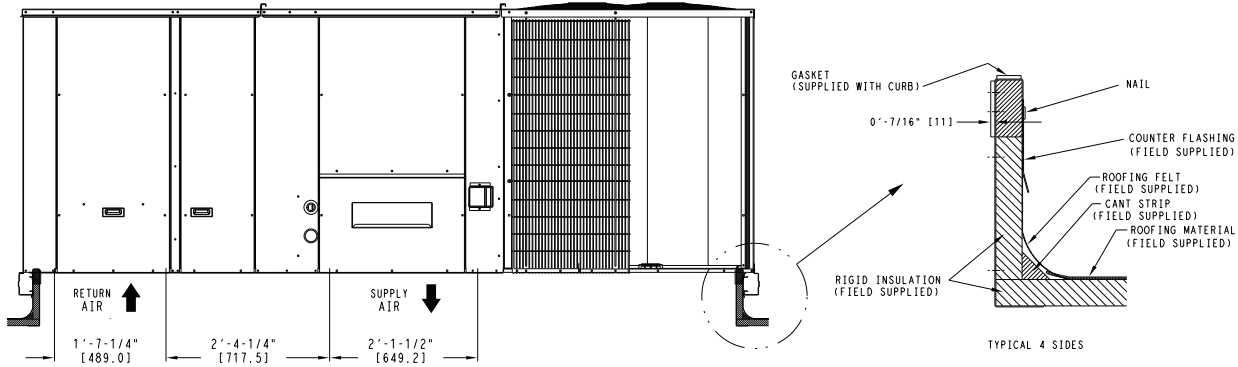
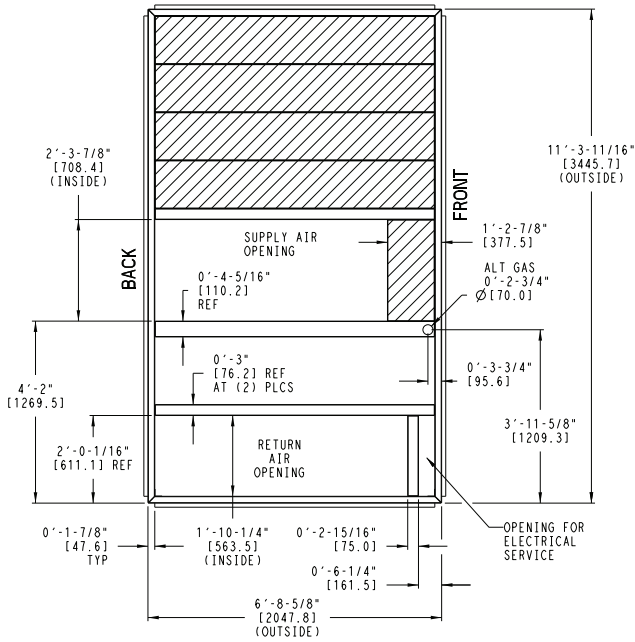

Fig. 6 - Roof Curb Details - 18 Size Unit

C13777

DIMENSIONS (cont.)

UNIT SIZE	"A"	ROOF CURB ACCESSORY
21, 25	1'-2" [356.0] 2'-0" [610.0]	CRRFCURB047A00 CRRFCURB048A00



NOTES:

- 1 ROOF CURB ACCESSORY IS SHIPPED UNASSEMBLED.
- 2 DIMENSIONS IN () ARE IN MILLIMETERS.
- 3 ROOF CURB GALVANIZED STEEL.
- 4 ATTACH DUCTWORK TO CURB (FLANGES ON DUCT REST ON CURB)
- 5 SERVICE CLEARANCE 4 FT ON EACH SIDE

➔ DIRECTION OF AIR FLOW

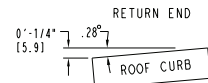
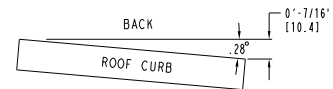

MAX CURB LEVELING TOLERANCES

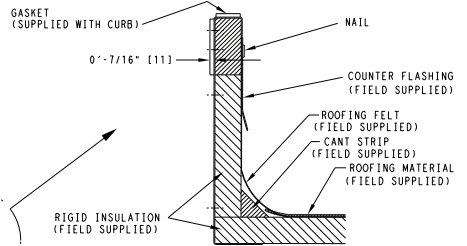
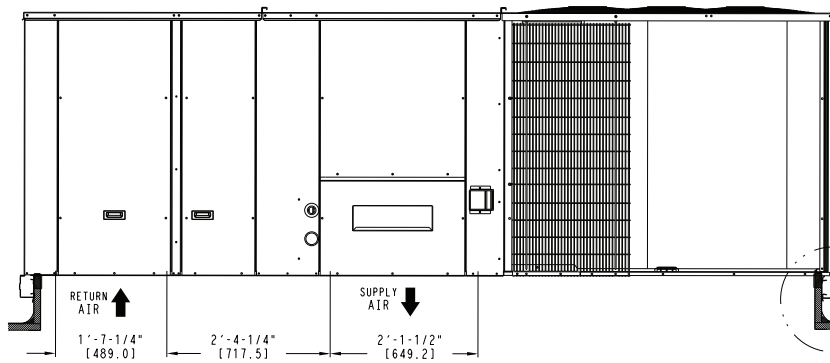

TYPICAL 4 SIDES

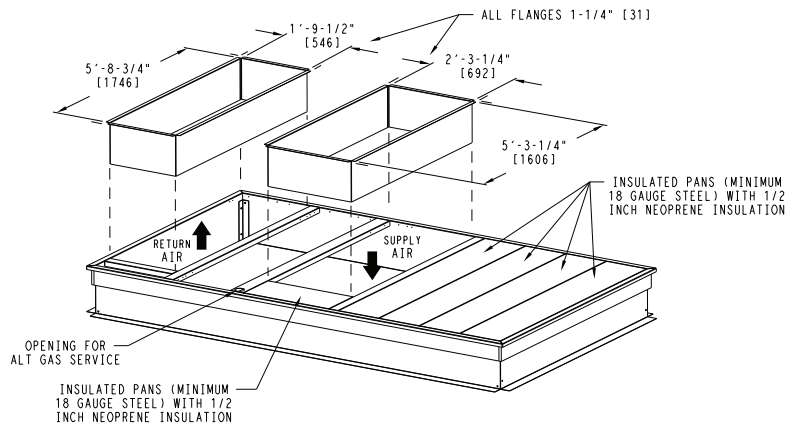
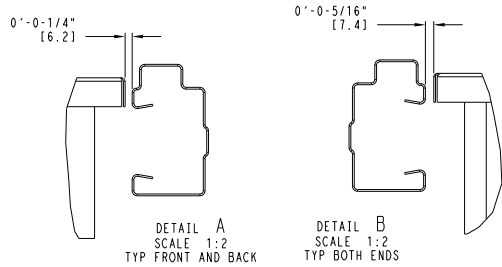
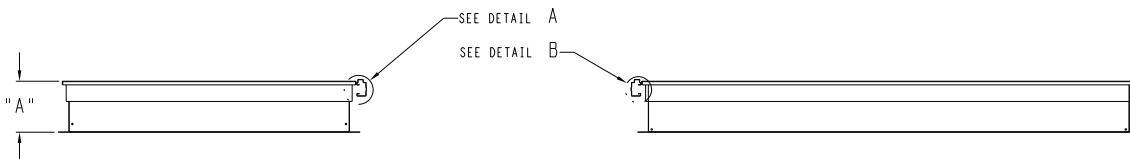
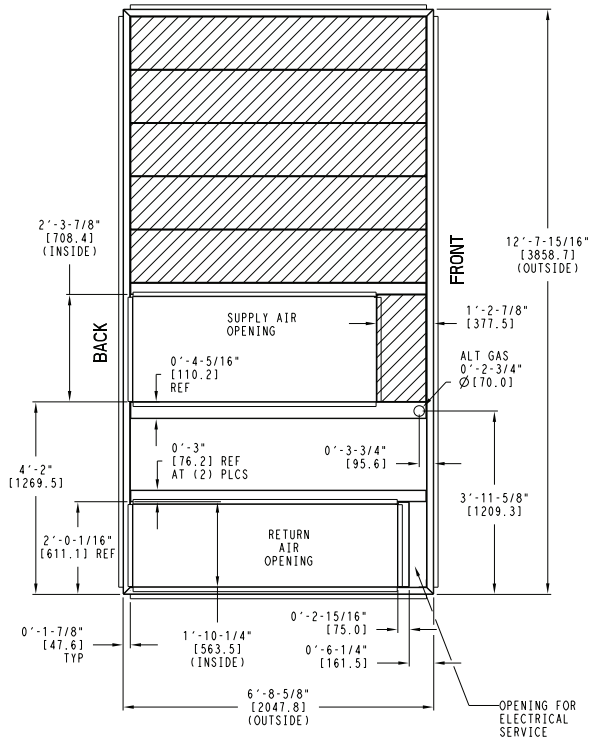

Fig. 7 - Roof Curb Details – 21 and 25 Size Units

C13778

DIMENSIONS (cont.)

UNIT SIZE	"A"	ROOF CURB ACCESSORY
29	1'-2" [356.0] 2'-0" [610.0]	CRRFCURB049A00 CRRFCURB050A00



- NOTES:
 1 ROOF CURB ACCESSORY IS SHIPPED UNASSEMBLED.
 2 BOLT HEADS TO BE ON INSIDE OF FLANGE. CLEARANCE IS (1) 0'-0-7/16" TYP ALL CORNERS.
 3 DIMENSIONS IN [] ARE IN MILLIMETERS.
 4 ROOF CURB GALVANIZED STEEL.
 5 ATTACH DUCTWORK TO CURB (FLANGES ON DUCT REST ON CURB)
 6 SERVICE CLEARANCE 4 FT ON EACH SIDE
 7 GAS SERVICE PLATE IS PART OF A SEPARATELY SHIPPED ACCESSORY PACKAGE.
 8 GAS SERVICE PLATE CAN BE USED WITH EITHER ACCESSORY ROOFCURB.

➔ DIRECTION OF AIR FLOW

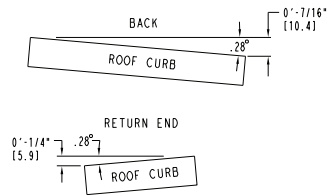

MAX CURB LEVELING TOLERANCES

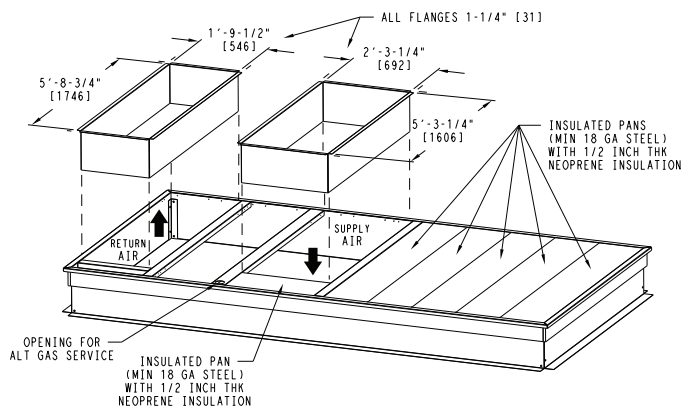
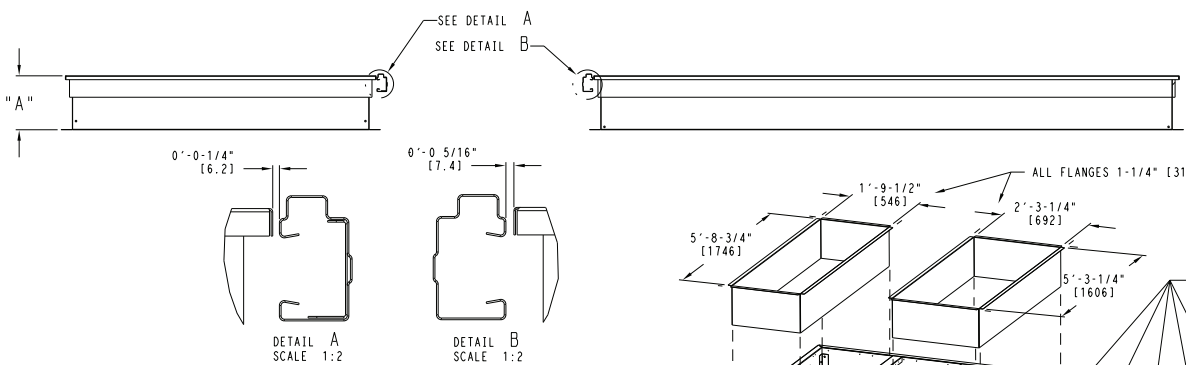
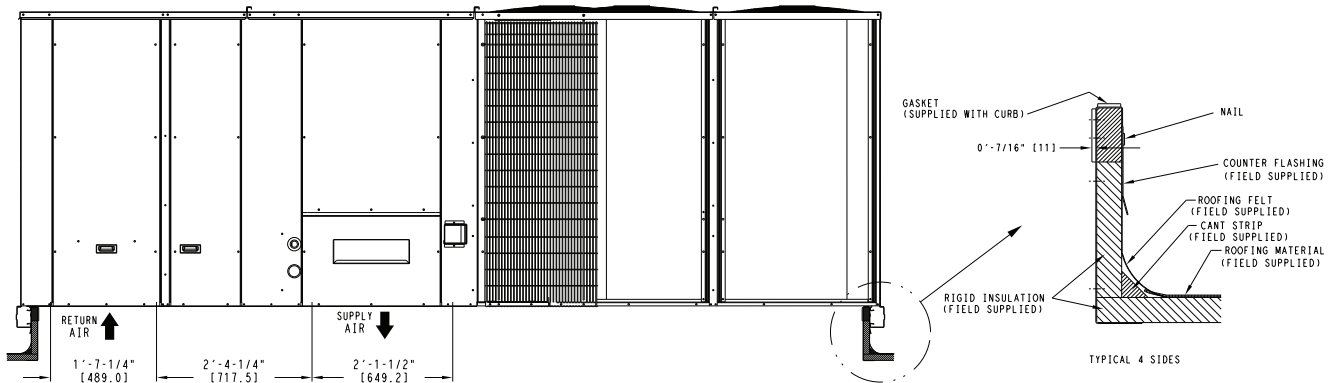

Fig. 8 - Roof Curb Details – 29 Size Unit

OPTIONS AND ACCESSORIES WEIGHT ADDERS

BASE UNIT WITH OPTIONS AND ACCESSORIES (Weight Adders)	MAX WEIGHT ADDER							
	48TC**18		48TC**21		48TC**25		48TC**29	
	lb	kg	lb	kg	lb	kg	lb	kg
Humidi–MiZer*	110	50	120	55	120	55	120	55
Base Unit Operating Weight	1892	858	2102	953	2247	1019	2292	1040
Power Exhaust	125	57	125	57	125	57	125	57
Economizer	246	112	246	112	246	112	246	112
Copper Tube/Fin Evaporator Coil	53	24	58	26	64	29	64	29
Low Gas Heat	85	39	85	39	85	39	85	39
Medium Gas Heat	90	41	90	41	90	41	90	41
High Gas Heat	113	51	113	51	113	51	113	51
Flue Discharge Deflector	7	3	7	3	7	3	7	3
Roof Curb 14–in (356mm)	240	109	255	116	255	116	255	116
Roof Curb 24–in (610mm)	340	154	355	161	355	161	355	161
Louvered Hail Guard	60	27	60	27	120	54	150	68
CO ₂ sensor	5	2	5	2	5	2	5	2
Return Smoke Detector	5	2	5	2	5	2	5	2
Supply Smoke Detector	5	2	5	2	5	2	5	2
Fan/Filter Status Switch	2	1	2	1	2	1	2	1
Non–Fused Disconnect	15	7	15	7	15	7	15	7
Powered Convenience Outlet	35	16	35	16	35	16	35	16
Non–Powered Convenience Outlet	5	2	5	2	5	2	5	2
Enthalpy Sensor	2	1	2	1	2	1	2	1
Differential Enthalpy Sensor	3	1	3	1	3	1	3	1
Two Position Motorized Damper	50	23	50	23	65	29	65	29
Manual Damper	35	16	35	16	35	16	40	18
Field Filter Track 4–in (102mm)	12	5	12	5	12	5	12	5
MotorMaster Controller	39	18	39	18	39	18	39	18
Standard Static Motor/Drive	0	0	0	0	0	0	0	0
Medium Static Motor/Drive	5	2	6	3	6	3	6	3
High Static Motor/Drive	11	5	12	5	16	7	16	7
Barometric Relief Hood (Horizontal)	25	11	25	11	25	11	25	11
SAV System with VFD	20	9	20	9	20	9	20	9

* For Humidi–MiZer add MotorMaster Controller

APPLICATION/SELECTION DATA

Min operating ambient temp (cooling):

In mechanical cooling mode, your Carrier rooftop unit can safely operate down to an outdoor ambient temperature of 35°F (2°C). It is possible to provide cooling at lower outdoor ambient temperatures by using less outside air, economizers, and/or accessory low ambient kits.

Max operating ambient temp (cooling):

The maximum operating ambient temperature for cooling mode is 115°F (46°C). While cooling operation above 115°F (46°C) may be possible, it could cause either a reduction in performance, reliability, or a protective action by the unit's internal safety devices.

Min mixed air temp (heating):

Using the factory settings, the minimum temperatures for the mixed air (the combined temperature of the warm return air and the cold outdoor air) entering the dimpled, gas heat exchangers are:

<u>Aluminized</u>	<u>Stainless Steel</u>
50°F (10°C) continuous	40°F (4°C) continuous
45°F (7°C) intermittent	35°F (2°C) intermittent

Operating at lower mixed-air temperatures may be possible, if a field-supplied, outdoor air thermostat initiates both heat stages when the temperature is less than the minimum temperatures listed above. Please contact your local Carrier representative for assistance.

Min and max airflow (heating and cooling):

To maintain safe and reliable operation of your rooftop, operate within the heating airflow limits during heating mode and cooling airflow limits during cooling mode. Operating above the max may cause blow-off, undesired airflow noise, or airflow related problems with the rooftop unit. Operating below the min may cause problems with coil freeze-up and unsafe heating operation. Heating and cooling limitations differ when evaluating operating CFM, the minimum value is the HIGHER of the cooling and heating minimum CFM values published in Table 5 and the maximum value is the LOWER of the cooling and heating minimum values published in Table 5.

Heating-to-cooling changeover:

Your unit will automatically change from heating to cooling mode when using a thermostat with an auto-change-over feature.

Airflow:

All units are draw-through in cooling mode and blow-through in heating mode.

Outdoor air application strategies:

Economizers reduce operating expenses and compressor run time by providing a free source of cooling and a means of ventilation to match application changing needs. In fact, they should be considered for most applications. Also, consider the various economizer control methods and their benefits, as well as sensors required to accomplish your application goals. Please contact your local Carrier representative for assistance.

Motor limits, break horsepower (BHP):

Due to internal design of Carrier units, the air path, and specially designed motors, the full horsepower (maximum continuous BHP) band, as listed in Physical Data Table Cooling, can be used with the utmost confidence. There is no need for extra safety factors, as Carrier motors are designed and rigorously tested to use the entire, listed BHP range without either nuisance tripping or premature motor failure.

Propane heating:

Propane has different physical qualities than natural gas. As a result, Propane requires different fuel to air mixture. To optimize the fuel/air mixture for Propane, Carrier sells different burner orifices in an easy to install accessory kit. To select the correct burner orifices or determine the heat capacity for an Propane application, use either the selection software, or the unit's service manual.

High altitude heating:

High altitudes have less oxygen, which affects the fuel/air mixture in heat exchangers. In order to maintain a proper fuel/air mixture, heat exchangers operating in altitudes above 2000 ft (610m) require different orifices. To select the correct burner orifices or determine the heat capacity for a high altitude application, use either the selection software, or the unit's service manual.

High altitudes have less oxygen, which means heat exchangers need less fuel. The new gas orifices in this field-installed kit make the necessary adjustment for high altitude applications. They restore the optimal fuel to air mixture and maintain healthy combustion on altitudes above 2000 ft (610m).

NOTE: Typical natural gas heating value ranges from 975 to 1050 Btu/ft³ at sea level nationally. The heating value goes down approximately 1.7% per every thousand feet elevation. Standard factory orifices can typically be used up to 2000 ft (610m) elevation without any operational issues.

NOTE: For installations in Canada, the input rating should be derated by 10% for altitudes from 2000 ft (610m) to 4500 ft (1372m) above sea level.

APPLICATION/SELECTION DATA (cont.)

Sizing a rooftop

Bigger isn't necessarily better. While an air conditioner needs to have enough capacity to meet the design loads, it doesn't need excess capacity. In fact, excess capacity typically results in very poor part load performance and humidity control.

Using higher design temperatures than ASHRAE recommends for your location, adding "safety factors" to the calculated load, are all signs of oversizing air conditioners. Oversizing the air conditioner leads to poor humidity control, reduced efficiency, higher utility bills, larger indoor temperature swings, excessive noise, and increased wear and tear on the air conditioner.

Rather than oversizing an air conditioner, engineers should "right-size" or even slightly undersize air conditioners. Correctly sizing an air conditioner controls humidity better; promotes efficiency; reduces utility bills; extends equipment life, and maintains even, comfortable temperatures. Please contact your local Carrier representative for assistance.

Low ambient applications

The optional Carrier economizer can adequately cool your space by bringing in fresh, cool outside air. In fact, when so equipped, accessory low-ambient kit may not be necessary. In low ambient conditions, unless the outdoor air is excessively humid or contaminated, economizer-based "free cooling" is the preferred less costly and energy conscious method.

In low ambient applications where outside air might not be desired (such as contaminated or excessively humid outdoor environments), your Carrier rooftop can operate to ambient temperatures down to -20°F (-29°C) using the recommended accessory Motormaster low ambient controller or down to 25°F (-4°C) with the field installed Winter Start Package.

Application/Selection Option

Selection software by Carrier saves time by performing many of the steps above. Contact your Carrier sales representative for assistance.

Staged Air Volume (SAV) with Variable Frequency Drive (VFD)

Carrier's Staged Air Volume (SAV) system utilizes a Variable Frequency Drive (VFD) to automatically adjust the indoor fan motor speed in sequence with the units cooling operation. Per ASHRAE 90.1 2010 standard section 6.4.3.10.b, during the first stage of cooling operation the VFD will adjust the fan motor to provide 2/3rd of the total cfm established for the unit. When a call for the second stage of cooling is required, the VFD will allow the total cfm for the unit established (100%). During the heating mode, the VFD will allow total design cfm (100%) operation and during the ventilation mode the VFD will allow operation to 2/3rd of total cfm.

The VFD used in Carrier's SAV system has soft start capabilities to slowly ramp up the speeds, thus eliminating any high inrush air volume during initial start-up. It also has internal over current protection for the fan motor and a field installed display kit that allows adjustment and in depth diagnostics of the VFD.

This SAV system is available on models with 2-stage cooling operation with electrical mechanical or RTU Open (multi Protocol) controls. Both space sensor and conventional thermostats controls can be used to provide accurate control in any application.

The SAV system is very flexible for initial fan performance set up and adjustment. The standard factory shipped VFD is pre programmed to automatically stage the fan speed between the first and second stage of cooling. The unit fan performance static pressure and cfm can be easily adjusted using the traditional means of pulley adjustments. The other means to adjust the unit static and cfm performance is to utilize the field installed display module and adjust the frequency and voltage in the VFD to required performance requirements. In either case, once set up the VFD will automatically adjust the speed between the cooling stage operation.

Table 9 – COOLING CAPACITIES

2-STAGE COOLING

15 TONS

48TC*D18				AMBIENT TEMPERATURE												
				85			95			105			115			
				EAT (db)			EAT (db)			EAT (db)			EAT (db)			
				75	80	85	75	80	85	75	80	85	75	80	85	
4500 CFM	EAT (wb)	58	THC	158.3	158.3	179.2	152.6	152.6	172.9	146.6	146.6	166.1	140.2	140.2	158.8	
			SHC	137.3	158.3	179.2	132.4	152.6	172.9	127.2	146.6	166.1	121.6	140.2	158.8	
		62	THC	166.8	166.8	169.0	159.5	159.5	165.6	151.8	151.8	161.9	143.6	143.6	157.9	
			SHC	123.1	146.1	169.0	119.7	142.6	165.6	116.1	139.0	161.9	112.3	135.1	157.9	
		67	THC	182.9	182.9	182.9	174.9	174.9	174.9	166.3	166.3	166.3	157.2	157.2	157.2	
			SHC	100.0	123.1	146.1	96.7	119.8	142.8	93.2	116.3	139.4	89.7	112.7	135.7	
	72	THC	200.5	200.5	200.5	191.6	191.6	191.6	182.2	182.2	182.2	172.2	172.2	172.2		
		SHC	76.1	99.5	122.8	72.9	96.2	119.5	69.5	92.8	116.1	66.0	89.3	112.5		
	76	THC	-	215.4	215.4	-	205.8	205.8	-	195.6	195.6	-	184.8	184.8		
		SHC	-	80.2	105.0	-	77.1	101.7	-	73.7	98.2	-	70.2	94.5		
	5250 CFM	EAT (wb)	58	THC	166.7	166.7	188.8	160.6	160.6	181.9	154.0	154.0	174.4	147.0	147.0	166.5
				SHC	144.6	166.7	188.8	139.3	160.6	181.9	133.6	154.0	174.4	127.6	147.0	166.5
62			THC	172.0	172.0	185.1	164.3	164.3	181.2	156.3	156.3	177.0	147.8	147.8	172.4	
			SHC	132.5	158.8	185.1	128.9	155.1	181.2	125.0	151.0	177.0	120.9	146.6	172.4	
67			THC	188.3	188.3	188.3	179.7	179.7	179.7	170.7	170.7	170.7	161.0	161.0	161.0	
			SHC	106.1	132.7	159.3	102.8	129.3	155.9	99.3	125.8	152.4	95.6	122.1	148.6	
72		THC	206.1	206.1	206.1	196.7	196.7	196.7	186.7	186.7	186.7	176.2	176.2	176.2		
		SHC	78.8	105.6	132.5	75.5	102.3	129.1	72.1	98.8	125.6	68.5	95.2	121.9		
76		THC	-	221.2	221.2	-	211.0	211.0	-	200.3	200.3	-	189.0	189.0		
		SHC	-	83.6	111.7	-	80.3	108.2	-	76.9	104.6	-	73.3	100.9		
6000 CFM		EAT (wb)	58	THC	173.8	173.8	196.8	167.2	167.2	189.4	160.2	160.2	181.4	152.7	152.7	173.0
				SHC	150.8	173.8	196.8	145.1	167.2	189.4	139.0	160.2	181.4	132.5	152.7	173.0
	62		THC	176.3	176.3	199.5	168.5	168.5	194.9	160.5	160.5	188.9	152.9	152.9	179.9	
			SHC	140.9	170.2	199.5	136.9	165.9	194.9	132.1	160.5	188.9	125.8	152.9	179.9	
	67		THC	192.3	192.3	192.3	183.4	183.4	183.4	173.9	173.9	173.9	164.0	164.0	164.0	
			SHC	112.0	142.0	172.0	108.5	138.5	168.5	104.9	134.9	164.8	101.2	131.1	161.0	
	72	THC	210.4	210.4	210.4	200.6	200.6	200.6	190.2	190.2	190.2	179.3	179.3	179.3		
		SHC	81.2	111.4	141.7	77.9	108.0	138.2	74.4	104.5	134.6	70.7	100.8	130.8		
	76	THC	-	225.6	225.6	-	215.0	215.0	-	203.8	203.8	-	192.1	192.1		
		SHC	-	86.7	117.9	-	83.3	114.5	-	79.9	110.8	-	76.3	107.1		
	6750 CFM	EAT (wb)	58	THC	179.8	179.8	203.7	172.9	172.9	195.8	165.5	165.5	187.4	157.5	157.5	178.4
				SHC	156.0	179.8	203.7	150.0	172.9	195.8	143.5	165.5	187.4	136.7	157.5	178.4
62			THC	180.5	180.5	210.7	173.0	173.0	203.6	165.6	165.6	194.9	157.7	157.7	185.5	
			SHC	147.6	179.2	210.7	142.4	173.0	203.6	136.3	165.6	194.9	129.8	157.7	185.5	
67			THC	195.6	195.6	195.6	186.2	186.2	186.2	176.5	176.5	176.8	166.2	166.2	172.7	
			SHC	117.5	150.8	184.1	114.0	147.3	180.5	110.4	143.6	176.8	106.5	139.6	172.7	
72		THC	213.8	213.8	213.8	203.6	203.6	203.6	192.9	192.9	192.9	181.6	181.6	181.6		
		SHC	83.5	117.0	150.5	80.1	113.5	147.0	76.5	109.9	143.3	72.8	106.1	139.4		
76		THC	-	229.1	229.1	-	218.1	218.1	-	206.6	206.6	-	194.6	194.6		
		SHC	-	89.6	124.0	-	86.2	120.5	-	82.7	116.8	-	79.0	113.0		
7500 CFM		EAT (wb)	58	THC	185.1	185.1	209.6	177.7	177.7	201.3	170.0	170.0	192.5	161.6	161.6	183.0
				SHC	160.6	185.1	209.6	154.2	177.7	201.3	147.5	170.0	192.5	140.2	161.6	183.0
	62		THC	185.2	185.2	218.0	177.9	177.9	209.3	170.1	170.1	200.2	161.8	161.8	190.4	
			SHC	152.5	185.2	218.0	146.4	177.9	209.3	140.0	170.1	200.2	133.2	161.8	190.4	
	67		THC	198.1	198.1	198.1	188.6	188.6	192.1	178.6	178.6	188.1	168.1	168.1	183.8	
			SHC	122.8	159.3	195.9	119.2	155.7	192.1	115.5	151.8	188.1	111.5	147.7	183.8	
	72	THC	216.6	216.6	216.6	206.1	206.1	206.1	195.1	195.1	195.1	183.5	183.5	183.5		
		SHC	85.6	122.3	159.0	82.2	118.8	155.5	78.6	115.2	151.7	74.9	111.3	147.8		
	76	THC	-	231.9	231.9	-	220.7	220.7	-	208.9	208.9	-	196.5	196.5		
		SHC	-	92.4	129.9	-	88.9	126.3	-	85.4	122.6	-	81.6	118.7		

Note: See Minimum–Maximum Airflow Ratings in Table 5. Do not operate outside these limits.

LEGEND:

- Do not operate
- Cfm - Cubic feet per minute (supply air)
- EAT(db) - Entering air temperature (dry bulb)
- EAT(wb) - Entering air temperature (wet bulb)
- SHC - Sensible heat capacity
- TC - Total capacity

Table 10 – COOLING CAPACITIES

2-STAGE COOLING

15 TONS (cont.)

48TCE18 (15 TONS) – UNIT WITH HUMIDI-MIZER IN SUBCOOLING MODE01										
Temp (F) Air Entering Condenser (Edb)		AIR ENTERING EVAPORATOR – CFM								
		4,500			6,000			7,500		
		Air Entering Evaporator -- Ewb (F)								
75	TC	202.9	184.6	166.2	213.7	194.6	175.4	222.3	202.5	182.7
	SHC	91.9	112.4	132.9	106.1	126.4	146.8	117.5	137.7	158.0
	kW	10.19	10.12	9.78	10.51	10.19	9.95	10.61	10.36	10.12
85	TC	189.8	171.8	153.8	201.0	182.2	163.3	209.9	190.4	170.8
	SHC	75.9	101.0	126.2	91.2	116.3	141.3	103.4	128.4	153.5
	kW	11.57	11.49	11.15	11.88	11.56	11.32	11.98	11.73	11.49
95	TC	176.7	159.1	141.4	188.3	169.7	151.2	197.5	178.2	159.0
	SHC	59.8	89.7	119.6	76.2	106.1	135.9	89.4	119.2	149.0
	kW	12.87	12.81	12.47	13.20	12.88	12.64	13.30	13.05	12.81
105	TC	163.6	146.3	129.0	175.6	157.3	139.1	185.1	166.1	147.1
	SHC	43.8	78.4	112.9	61.3	95.9	130.4	75.3	109.9	144.4
	kW	14.05	14.00	13.65	14.39	14.07	13.82	14.40	14.24	14.00
115	TC	150.5	133.5	116.5	162.9	144.9	127.0	172.7	154.0	135.3
	SHC	27.7	67.0	106.3	46.4	85.7	125.0	61.3	100.6	133.4
	kW	15.44	15.36	15.02	15.75	15.43	15.19	15.85	15.60	15.36

48TCE18 (15 TONS) – UNIT WITH HUMIDI-MIZER IN HOT GAS REHEAT MODE										
Temp (F) Air Entering Condenser (Edb)		AIR ENTERING EVAPORATOR – Ewb (F)								
		75 Dry Bulb			75 Dry Bulb			75 Dry Bulb		
		62.5 Wet Bulb			64 Wet Bulb			65.3 Wet Bulb		
		(50% Relative)			(56% Relative)			(60% Relative)		
		Air Entering Evaporator – Cfm								
		4,500	6,000	7,500	4,500	6,000	7,500	4,500	6,000	7,500
80	TC	64.50	71.00	73.30	68.40	74.50	77.30	71.20	79.70	80.60
	SHC	12.60	24.90	36.80	6.80	13.70	23.90	-0.80	5.50	13.80
	kW	10.10	10.26	10.42	10.18	10.40	10.56	10.33	10.47	10.67
75	TC	66.60	73.10	75.60	70.50	76.60	79.50	73.20	80.80	82.90
	SHC	14.30	26.70	38.50	8.10	14.90	25.70	0.70	7.00	15.00
	kW	10.05	10.22	10.36	10.14	10.36	10.52	10.28	10.43	10.62
70	TC	68.70	75.10	77.40	72.50	78.60	81.40	75.20	82.80	84.90
	SHC	15.40	27.80	40.00	9.50	16.20	26.80	2.10	8.40	16.30
	kW	10.00	10.18	10.33	10.10	10.31	10.47	10.23	10.40	10.58
60	TC	72.80	79.30	81.60	76.70	82.80	85.70	79.40	86.90	88.80
	SHC	19.00	31.10	43.20	12.70	19.90	30.10	5.30	11.60	20.00
	kW	9.92	10.09	10.24	10.01	10.22	10.37	10.14	10.31	10.49
50	TC	76.80	83.40	85.70	80.80	86.90	89.70	83.50	90.90	92.80
	SHC	21.70	34.20	46.20	15.80	22.70	33.20	8.40	14.70	22.80
	kW	9.83	10.00	10.15	9.92	10.13	10.29	10.05	10.21	10.39
40	TC	80.90	87.30	89.60	84.90	90.80	93.60	87.40	94.80	96.70
	SHC	24.90	37.10	49.30	19.00	26.00	36.10	11.60	17.90	26.20
	kW	9.74	9.91	10.06	9.83	10.04	10.20	9.96	10.12	10.30

LEGEND

- Edb – Entering Dry-Bulb
- Ewb – Entering Wet-Bulb
- kW – Compressor Motor Power Input
- ldb – Leaving Dry-Bulb
- lwb – Leaving Wet-Bulb
- SHC – Sensible Heat Capacity (1000 Btuh) Gross
- TC – Total Capacity (1000 Btuh) Gross

NOTES:

1. Direct interpolation is permissible. Do not extrapolate.
2. The following formulas may be used:

$$t_{ldb} = t_{edb} - \frac{\text{sensible capacity (Btuh)}}{1.10 \times \text{cfm}}$$

t_{lwb} = Wet-bulb temperature corresponding to enthalpy of air leaving evaporator coil (h_{lwb})

$$h_{lwb} = h_{ewb} - \frac{\text{total capacity (Btuh)}}{4.5 \times \text{cfm}}$$

Where: h_{ewb} = Enthalpy of air entering evaporator coil

Table 11 – COOLING CAPACITIES

2-STAGE COOLING

17.5 TONS

48TC*D21			AMBIENT TEMPERATURE												
			85			95			105			115			
			EAT (db)			EAT (db)			EAT (db)			EAT (db)			
CFM	EAT (wb)	Temp	75	80	85	75	80	85	75	80	85	75	80	85	
			5250	58	THC	185.1	185.1	209.2	178.7	178.7	201.9	171.8	171.8	194.1	164.5
SHC	161.1	185.1			209.2	155.4	178.7	201.9	149.4	171.8	194.1	143.1	164.5	185.8	
62	THC	193.8		193.8	199.5	185.6	185.6	195.4	176.9	176.9	191.1	167.7	167.7	186.4	
	SHC	145.6		172.6	199.5	141.7	168.6	195.4	137.6	164.4	191.1	133.2	159.8	186.4	
67	THC	212.2		212.2	212.2	203.3	203.3	203.3	193.8	193.8	193.8	183.8	183.8	183.8	
	SHC	119.0		146.0	173.1	115.3	142.3	169.4	111.4	138.4	165.4	107.3	134.3	161.3	
72	THC	232.3		232.3	232.3	222.7	222.7	222.7	212.4	212.4	212.4	201.6	201.6	201.6	
	SHC	91.5		118.8	146.2	87.9	115.2	142.5	84.1	111.4	138.7	80.2	107.4	134.6	
76	THC	-		249.5	249.5	-	239.2	239.2	-	228.2	228.2	-	216.6	216.6	
	SHC	-		96.7	125.3	-	93.2	121.7	-	89.5	117.9	-	85.6	113.8	
6125	58	THC		194.7	194.7	220.0	187.8	187.8	212.2	180.4	180.4	203.8	172.5	172.5	194.9
		SHC		169.4	194.7	220.0	163.3	187.8	212.2	156.9	180.4	203.8	150.1	172.5	194.9
	62	THC	199.6	199.6	218.0	191.1	191.1	213.5	182.1	182.1	208.4	173.0	173.0	201.2	
		SHC	156.5	187.2	218.0	152.3	182.9	213.5	147.7	178.0	208.4	141.8	171.5	201.2	
	67	THC	218.0	218.0	218.0	208.7	208.7	208.7	198.7	198.7	198.7	188.2	188.2	188.2	
		SHC	126.2	157.4	188.6	122.4	153.6	184.7	118.4	149.6	180.7	114.3	145.4	176.5	
	72	THC	238.5	238.5	238.5	228.4	228.4	228.4	217.7	217.7	217.7	206.3	206.3	206.3	
		SHC	94.7	126.1	157.5	91.0	122.4	153.8	87.2	118.5	149.8	83.1	114.4	145.7	
	76	THC	-	255.9	255.9	-	245.1	245.1	-	233.6	233.6	-	221.4	221.4	
		SHC	-	100.7	133.3	-	97.1	129.6	-	93.3	125.6	-	89.3	121.5	
	7000	58	THC	202.7	202.7	229.1	195.4	195.4	220.8	187.5	187.5	211.9	179.2	179.2	202.5
			SHC	176.4	202.7	229.1	170.0	195.4	220.8	163.1	187.5	211.9	155.9	179.2	202.5
62		THC	204.6	204.6	234.4	196.0	196.0	228.0	187.7	187.7	220.3	179.3	179.3	210.5	
		SHC	166.0	200.2	234.4	160.8	194.4	228.0	155.1	187.7	220.3	148.2	179.3	210.5	
67		THC	222.5	222.5	222.5	212.8	212.8	212.8	202.4	202.4	202.4	191.5	191.5	191.5	
		SHC	133.0	168.2	203.4	129.2	164.3	199.5	125.1	160.3	195.4	120.9	156.0	191.0	
72		THC	243.3	243.3	243.3	232.7	232.7	232.7	221.6	221.6	221.6	209.9	209.9	209.9	
		SHC	97.5	132.9	168.3	93.8	129.2	164.5	89.9	125.2	160.5	85.8	121.1	156.3	
76		THC	-	260.8	260.8	-	249.6	249.6	-	237.7	237.7	-	225.1	225.1	
		SHC	-	104.4	140.8	-	100.7	137.0	-	96.9	133.0	-	92.8	128.8	
7875		58	THC	209.6	209.6	236.8	201.8	201.8	228.1	193.6	193.6	218.8	184.8	184.8	208.9
			SHC	182.3	209.6	236.8	175.6	201.8	228.1	168.4	193.6	218.8	160.8	184.8	208.9
	62	THC	209.8	209.8	246.2	202.0	202.0	237.1	193.8	193.8	227.4	185.0	185.0	217.1	
		SHC	173.4	209.8	246.2	167.0	202.0	237.1	160.1	193.8	227.4	152.9	185.0	217.1	
	67	THC	226.1	226.1	226.1	216.0	216.0	216.0	205.4	205.4	209.4	194.2	194.2	204.8	
		SHC	139.6	178.6	217.7	135.6	174.7	213.7	131.5	170.5	209.4	127.1	166.0	204.8	
	72	THC	247.0	247.0	247.0	236.2	236.2	236.2	224.7	224.7	224.7	212.7	212.7	212.7	
		SHC	100.2	139.5	178.8	96.5	135.7	174.9	92.5	131.7	170.9	88.4	127.5	166.6	
	76	THC	-	264.7	264.7	-	253.1	253.1	-	240.9	240.9	-	227.9	227.9	
		SHC	-	107.9	148.1	-	104.2	144.3	-	100.2	140.2	-	96.1	135.9	
	8750	58	THC	215.4	215.4	243.4	207.3	207.3	234.3	198.7	198.7	224.6	189.6	189.6	214.2
			SHC	187.4	215.4	243.4	180.3	207.3	234.3	172.9	198.7	224.6	164.9	189.6	214.2
62		THC	215.5	215.5	253.0	207.5	207.5	243.5	198.9	198.9	233.4	189.7	189.7	222.7	
		SHC	178.1	215.5	253.0	171.5	207.5	243.5	164.4	198.9	233.4	156.8	189.7	222.7	
67		THC	228.9	228.9	231.5	218.7	218.7	227.3	207.8	207.8	222.8	196.4	196.4	217.9	
		SHC	145.8	188.6	231.5	141.8	184.5	227.3	137.5	180.1	222.8	133.0	175.5	217.9	
72		THC	250.1	250.1	250.1	239.0	239.0	239.0	227.3	227.3	227.3	214.9	214.9	214.9	
		SHC	102.8	145.8	188.9	99.0	142.0	185.0	95.0	137.9	180.9	90.8	133.7	176.5	
76		THC	-	267.8	267.8	-	256.0	256.0	-	243.5	243.5	-	230.2	230.2	
		SHC	-	111.2	155.2	-	107.4	151.3	-	103.5	147.1	-	99.3	142.8	

Note: See Minimum–Maximum Airflow Ratings in Table 5. Do not operate outside these limits.

LEGEND:

- Do not operate
- Cfm - Cubic feet per minute (supply air)
- EAT(db) - Entering air temperature (dry bulb)
- EAT(wb) - Entering air temperature (wet bulb)
- SHC - Sensible heat capacity
- TC - Total capacity

Table 12 – COOLING CAPACITIES

2-STAGE COOLING

17.5 TONS (cont.)

48TCE21 (17.5 TONS) – UNIT WITH HUMIDI-MIZER IN SUBCOOLING MODE										
Temp (F) Air Entering Condenser (Edb)		AIR ENTERING EVAPORATOR – CFM								
		5,250			7,000			8,750		
		Air Entering Evaporator – Ewb (F)								
		72	67	62	72	67	62	72	67	62
75	TC	232.0	211.3	190.6	242.4	221.0	199.7	250.7	228.9	207.0
	SHC	110.9	133.7	156.4	127.6	150.3	173.0	141.1	163.7	186.4
	kW	12.45	12.16	11.81	12.74	12.41	12.02	12.93	12.51	12.18
85	TC	215.9	195.7	175.5	226.0	205.2	184.4	234.2	212.8	191.5
	SHC	90.6	118.8	147.0	108.4	136.6	164.9	122.7	151.0	179.2
	kW	13.48	13.20	12.88	13.77	13.47	13.07	13.96	13.58	13.23
95	TC	199.7	180.0	160.3	209.7	189.4	169.1	217.6	196.8	176.1
	SHC	70.3	104.0	137.7	89.2	123.0	156.7	104.4	138.2	172.1
	kW	14.60	14.25	13.94	14.89	14.51	14.15	15.08	14.63	14.31
105	TC	183.6	164.5	145.2	193.3	173.5	153.8	201.0	180.8	160.6
	SHC	50.0	89.1	128.3	70.0	109.3	148.6	86.0	125.5	158.6
	kW	15.64	15.36	15.01	15.93	15.60	15.21	16.12	15.72	15.37
115	TC	167.5	148.8	130.1	176.9	157.7	138.5	184.5	164.8	145.1
	SHC	29.7	74.3	118.9	50.7	95.6	138.1	67.7	112.7	145.1
	kW	16.70	16.38	15.82	16.98	16.63	16.03	17.17	16.75	16.19

48TCE21 (17.5 TONS) – UNIT WITH HUMIDI-MIZER IN HOT GAS REHEAT MODE										
Temp (F) Air Entering Condenser (Edb)		AIR ENTERING EVAPORATOR – Ewb (F)								
		75 Dry Bulb			75 Dry Bulb			75 Dry Bulb		
		62.5 Wet Bulb			64 Wet Bulb			65.3 Wet Bulb		
		(50% Relative)			(56% Relative)			(60% Relative)		
		Air Entering Evaporator – Cfm								
		5,250	7,000	8,750	5,250	7,000	8,750	5,250	7,000	8,750
80	TC	67.80	71.30	74.10	70.50	74.80	79.80	73.30	78.20	82.40
	SHC	9.00	26.50	41.70	2.20	13.20	26.90	-5.20	2.90	13.80
	kW	11.65	11.75	11.87	11.82	11.90	11.98	11.93	12.10	12.19
75	TC	72.50	76.00	78.80	75.00	79.20	84.30	78.00	83.00	86.90
	SHC	13.40	30.90	46.10	6.50	18.00	31.30	-2.10	7.20	17.90
	kW	11.44	11.54	11.66	11.61	11.68	11.75	11.70	11.86	11.95
70	TC	77.10	80.60	83.40	79.50	83.90	88.90	82.40	87.30	91.10
	SHC	17.60	34.70	49.90	10.80	22.20	35.10	3.20	11.50	22.20
	kW	11.22	11.33	11.45	11.40	11.46	11.54	11.49	11.64	11.75
60	TC	86.30	89.90	92.70	88.80	93.20	98.20	91.70	96.60	100.50
	SHC	26.20	43.20	58.40	19.40	30.80	43.60	11.60	20.10	30.70
	kW	10.76	10.86	10.98	10.93	11.00	11.07	11.03	11.18	11.28
50	TC	95.50	99.10	101.90	98.00	102.40	107.40	101.00	106.00	109.80
	SHC	34.80	51.80	67.00	28.00	39.40	52.20	20.10	28.70	39.40
	kW	10.33	10.43	10.55	10.50	10.52	10.63	10.59	10.74	10.85
40	TC	104.80	108.40	111.20	107.30	111.70	116.60	110.30	115.30	119.10
	SHC	43.40	60.40	75.60	36.60	48.00	60.80	28.80	37.30	47.90
	kW	9.87	9.97	10.09	10.04	10.11	10.18	10.14	10.28	10.40

LEGEND

- Edb – Entering Dry-Bulb
- Ewb – Entering Wet-Bulb
- kW – Compressor Motor Power Input
- ldb – Leaving Dry-Bulb
- lwb – Leaving Wet-Bulb
- SHC – Sensible Heat Capacity (1000 Btuh) Gross
- TC – Total Capacity (1000 Btuh) Gross

NOTES:

1. Direct interpolation is permissible. Do not extrapolate.
2. The following formulas may be used:

$$t_{ldb} = t_{edb} - \frac{\text{sensible capacity (Btuh)}}{1.10 \times \text{cfm}}$$

$$t_{lwb} = \text{Wet-bulb temperature corresponding to enthalpy of air leaving evaporator coil (} h_{lwb} \text{)}$$

$$h_{lwb} = h_{ewb} - \frac{\text{total capacity (Btuh)}}{4.5 \times \text{cfm}}$$

Where: h_{ewb} = Enthalpy of air entering evaporator coil

Table 13 – COOLING CAPACITIES

2-STAGE COOLING

20 TONS

48TC*D25			AMBIENT TEMPERATURE													
			85			95			105			115				
			EA (db)			EA (db)			EA (db)			EA (db)				
			75	80	85	75	80	85	75	80	85	75	80	85		
6000 CFM	EAT (wb)	58	THC	214.4	214.4	242.5	207.0	207.0	234.2	199.0	199.0	225.1	190.2	190.2	215.2	
		58	SHC	186.3	214.4	242.5	179.9	207.0	234.2	173.0	199.0	225.1	165.3	190.2	215.2	
		62	THC	226.8	226.8	227.7	217.3	217.3	223.0	206.9	206.9	218.0	195.8	195.8	212.5	
			SHC	167.0	197.3	227.7	162.4	192.7	223.0	157.6	187.8	218.0	152.3	182.4	212.5	
		67	THC	248.4	248.4	248.4	237.9	237.9	237.9	226.6	226.6	226.6	214.3	214.3	214.3	
			SHC	136.5	167.1	197.6	132.2	162.7	193.2	127.5	158.0	188.4	122.5	152.9	183.4	
	72	THC	271.9	271.9	271.9	260.3	260.3	260.3	247.9	247.9	247.9	234.5	234.5	234.5		
		SHC	105.1	136.0	167.0	100.8	131.7	162.5	96.3	127.1	157.9	91.4	122.1	152.9		
	76	THC	-	291.7	291.7	-	279.2	279.2	-	265.7	265.7	-	251.3	251.3		
		SHC	-	110.7	143.7	-	106.5	139.5	-	102.0	134.7	-	97.2	129.7		
	7000 CFM	EAT (wb)	58	THC	225.8	225.8	255.3	217.8	217.8	246.3	209.1	209.1	236.5	199.6	199.6	225.7
			58	SHC	196.2	225.8	255.3	189.3	217.8	246.3	181.7	209.1	236.5	173.4	199.6	225.7
62			THC	233.9	233.9	248.8	223.8	223.8	243.8	213.1	213.1	238.2	201.4	201.4	231.8	
			SHC	179.4	214.1	248.8	174.6	209.2	243.8	169.4	203.8	238.2	163.7	197.8	231.8	
67			THC	255.7	255.7	255.7	244.6	244.6	244.6	232.6	232.6	232.6	219.6	219.6	219.6	
			SHC	144.7	179.7	214.8	140.2	175.2	210.2	135.4	170.4	205.4	130.3	165.2	200.2	
72		THC	279.4	279.4	279.4	267.3	267.3	267.3	254.1	254.1	254.1	240.1	240.1	240.1		
		SHC	108.7	144.1	179.6	104.3	139.7	175.1	99.6	135.0	170.3	94.7	129.9	165.1		
76		THC	-	299.4	299.4	-	286.2	286.2	-	272.1	272.1	-	256.9	256.9		
		SHC	-	115.3	152.9	-	110.9	148.2	-	106.3	143.3	-	101.3	138.0		
8000 CFM		EAT (wb)	58	THC	235.3	235.3	266.2	226.8	226.8	256.5	217.5	217.5	246.0	207.4	207.4	234.5
			58	SHC	204.5	235.3	266.2	197.1	226.8	256.5	189.0	217.5	246.0	180.2	207.4	234.5
	62		THC	239.7	239.7	268.1	229.4	229.4	262.0	219.0	219.0	253.3	208.3	208.3	241.9	
			SHC	190.7	229.4	268.1	185.4	223.7	262.0	178.6	215.9	253.3	170.4	206.2	241.9	
	67		THC	261.3	261.3	261.3	249.6	249.6	249.6	237.1	237.1	237.1	223.6	223.6	223.6	
			SHC	152.3	191.8	231.2	147.7	187.1	226.6	142.9	182.2	221.6	137.7	177.0	216.3	
	72	THC	285.3	285.3	285.3	272.5	272.5	272.5	258.9	258.9	258.9	244.2	244.2	244.2		
		SHC	111.9	151.7	191.5	107.5	147.2	186.9	102.7	142.4	182.0	97.7	137.2	176.7		
	76	THC	-	305.4	305.4	-	291.6	291.6	-	276.8	276.8	-	261.2	261.2		
		SHC	-	119.4	161.0	-	114.9	156.2	-	110.1	151.2	-	105.1	146.0		
	9000 CFM	EAT (wb)	58	THC	243.5	243.5	275.4	234.5	234.5	265.2	224.6	224.6	254.0	213.9	213.9	241.9
			58	SHC	211.6	243.5	275.4	203.8	234.5	265.2	195.2	224.6	254.0	185.9	213.9	241.9
62			THC	245.4	245.4	282.9	235.4	235.4	274.6	225.0	225.0	264.3	214.4	214.4	251.7	
			SHC	199.7	241.3	282.9	193.2	233.9	274.6	185.6	224.9	264.3	176.8	214.3	251.7	
67			THC	265.6	265.6	265.6	253.6	253.6	253.6	240.7	240.7	240.7	226.8	226.8	231.8	
			SHC	159.6	203.3	247.1	154.9	198.6	242.3	150.0	193.6	237.3	144.7	188.3	231.8	
72		THC	289.9	289.9	289.9	276.7	276.7	276.7	262.6	262.6	262.6	247.5	247.5	247.5		
		SHC	114.9	159.0	203.0	110.4	154.4	198.3	105.6	149.5	193.3	100.5	144.2	188.0		
76		THC	-	310.1	310.1	-	295.8	295.8	-	280.6	280.6	-	264.4	264.4		
		SHC	-	123.2	168.9	-	118.6	164.1	-	113.8	159.0	-	108.7	153.6		
10,000 CFM		EAT (wb)	58	THC	250.4	250.4	283.2	240.9	240.9	272.5	230.7	230.7	260.9	219.5	219.5	248.2
			58	SHC	217.7	250.4	283.2	209.4	240.9	272.5	200.5	230.7	260.9	190.7	219.5	248.2
	62		THC	250.8	250.8	294.6	241.1	241.1	283.3	231.1	231.1	271.4	219.6	219.6	258.0	
			SHC	207.0	250.8	294.6	199.0	241.1	283.3	190.7	231.1	271.4	181.2	219.6	258.0	
	67		THC	269.2	269.2	269.2	256.8	256.8	257.6	243.5	243.5	252.3	229.4	229.4	246.4	
			SHC	166.6	214.5	262.5	161.9	209.7	257.6	156.8	204.5	252.3	151.3	198.9	246.4	
	72	THC	293.7	293.7	293.7	280.1	280.1	280.1	265.6	265.6	265.6	250.2	250.2	250.2		
		SHC	117.8	166.0	214.2	113.2	161.3	209.3	108.3	156.3	204.3	103.2	151.0	198.8		
	76	THC	-	313.9	313.9	-	299.3	299.3	-	283.7	283.7	-	267.1	267.1		
		SHC	-	126.8	176.5	-	122.2	171.6	-	117.3	166.5	-	112.1	161.0		

Note: See Minimum–Maximum Airflow Ratings in Table 5. Do not operate outside these limits.

LEGEND:

- Do not operate
- Cfm - Cubic feet per minute (supply air)
- EAT(db) - Entering air temperature (dry bulb)
- EAT(wb) - Entering air temperature (wet bulb)
- SHC - Sensible heat capacity
- TC - Total capacity

Table 14 – COOLING CAPACITIES

2-STAGE COOLING

20 TONS (cont.)

48TCE25 (20 TONS) – UNIT WITH HUMIDI-MIZER IN SUBCOOLING MODE										
Temp (F) Air Entering Condenser (Edb)		AIR ENTERING EVAPORATOR – CFM								
		6,000			8,000			10,000		
		Air Entering Evaporator – Ewb (F)								
		72	67	62	72	67	62	72	67	62
75	TC	281.6	256.5	231.3	293.1	267.0	240.9	302.3	275.4	248.6
	SHC	114.7	141.0	167.4	140.6	166.6	192.6	161.6	187.3	212.9
	kW	13.52	13.25	12.95	13.82	13.46	13.21	13.97	13.60	13.31
85	TC	261.3	236.9	212.4	272.1	247.7	221.3	280.7	254.6	228.5
	SHC	90.9	123.5	156.1	118.8	151.1	183.3	141.4	173.4	205.4
	kW	14.95	14.68	14.48	15.25	14.89	14.64	15.40	15.03	14.74
95	TC	241.1	217.2	193.4	251.1	226.4	201.7	259.2	233.8	208.4
	SHC	67.2	106.0	144.8	97.1	120.1	174.1	121.2	159.5	197.8
	kW	16.52	16.25	15.95	16.82	16.46	16.21	16.97	16.60	16.31
105	TC	220.8	197.5	174.4	230.2	206.2	182.2	237.7	213.0	188.4
	SHC	43.4	88.4	133.5	75.3	120.1	164.9	101.0	145.7	178.9
	kW	18.09	17.82	17.52	18.39	18.03	17.78	18.54	18.17	17.88
115	TC	200.5	178.0	155.5	209.2	185.9	162.6	216.2	192.2	168.7
	SHC	19.7	70.9	122.2	53.5	104.6	155.7	80.9	131.8	161.2
	kW	19.65	19.38	19.08	19.95	19.59	19.34	20.10	19.73	19.44

48TCE25 (20 TONS) – UNIT WITH HUMIDI-MIZER IN HOT GAS REHEAT MODE										
Temp (F) Air Entering Condenser (Edb)		AIR ENTERING EVAPORATOR – Ewb (F)								
		75 Dry Bulb			75 Dry Bulb			75 Dry Bulb		
		62.5 Wet Bulb			64 Wet Bulb			65.3 Wet Bulb		
		(50% Relative)			(56% Relative)			(60% Relative)		
		Air Entering Evaporator – Cfm								
		6,000	8,000	10,000	6,000	8,000	10,000	6,000	8,000	10,000
80	TC	115.20	123.30	130.60	120.40	129.30	138.20	122.80	135.00	143.70
	SHC	40.80	58.30	76.10	32.30	45.50	60.40	20.10	34.30	48.00
	kW	13.24	13.32	13.39	13.43	13.57	13.65	13.49	13.68	13.74
75	TC	119.80	128.60	135.90	125.50	135.30	143.20	128.00	139.50	148.40
	SHC	45.60	62.80	82.10	37.00	49.80	65.20	24.30	38.70	52.60
	kW	13.05	13.10	13.17	13.21	13.35	13.43	13.27	13.46	13.52
70	TC	122.50	133.10	140.20	129.80	140.70	147.60	132.40	144.40	153.20
	SHC	49.80	76.00	86.10	41.10	54.30	69.20	28.80	41.40	56.80
	kW	12.80	12.87	12.94	12.98	13.12	13.20	13.04	13.23	13.29
60	TC	133.80	142.50	149.60	139.30	150.40	157.40	141.50	154.20	163.00
	SHC	58.60	76.00	95.00	50.20	63.50	78.10	37.80	52.10	65.90
	kW	12.34	12.42	12.49	12.53	12.67	12.75	12.59	12.78	12.84
50	TC	143.50	151.80	159.30	149.00	160.00	167.00	151.30	163.60	172.50
	SHC	67.70	84.80	103.80	59.10	72.40	87.00	46.70	61.00	74.90
	kW	11.88	11.95	12.03	12.07	12.21	12.29	12.13	12.32	12.38
40	TC	153.20	161.30	168.70	158.60	169.20	176.60	160.80	173.10	182.00
	SHC	76.50	93.60	111.60	68.00	81.50	95.80	55.80	69.80	84.00
	kW	11.42	11.49	11.56	11.60	11.74	11.82	11.66	11.85	11.91

LEGEND

- Edb – Entering Dry-Bulb
- Ewb – Entering Wet-Bulb
- kW – Compressor Motor Power Input
- ldb – Leaving Dry-Bulb
- lwb – Leaving Wet-Bulb
- SHC – Sensible Heat Capacity (1000 Btuh) Gross
- TC – Total Capacity (1000 Btuh) Gross

NOTES:

1. Direct interpolation is permissible. Do not extrapolate.
2. The following formulas may be used:

$$t_{ldb} = t_{edb} - \frac{\text{sensible capacity (Btuh)}}{1.10 \times \text{cfm}}$$

$$t_{lwb} = \text{Wet-bulb temperature corresponding to enthalpy of air leaving evaporator coil (} h_{lwb} \text{)}$$

$$h_{lwb} = h_{ewb} - \frac{\text{total capacity (Btuh)}}{4.5 \times \text{cfm}}$$

Where: h_{ewb} = Enthalpy of air entering evaporator coil

Table 15 – COOLING CAPACITIES

2-STAGE COOLING

25 TONS

48TC*E29			AMBIENT TEMPERATURE														
			85			95			105			115					
			EA (db)			EA (db)			EA (db)			EA (db)					
			75	80	85	75	80	85	75	80	85	75	80	85			
7,500 CFM	EAT (wb)	58	THC	264.4	264.4	298.9	254.6	254.6	287.9	244.1	244.1	276.0	232.7	232.7	263.1		
		58	SHC	229.9	264.4	298.9	221.4	254.6	287.9	212.2	244.1	276.0	202.3	232.7	263.1		
		62	THC	278.7	278.7	282.4	266.3	266.3	276.4	252.8	252.8	269.8	238.5	238.5	262.4		
		62	SHC	206.8	244.6	282.4	200.9	238.7	276.4	194.6	232.2	269.8	187.7	225.0	262.4		
		67	THC	305.3	305.3	305.3	291.9	291.9	291.9	277.3	277.3	277.3	261.5	261.5	261.5		
		67	SHC	169.0	207.0	245.0	163.4	201.4	239.4	157.4	195.3	233.3	151.0	188.9	226.8		
	76	72	THC	334.0	334.0	334.0	319.4	319.4	319.4	303.6	303.6	303.6	286.5	286.5	286.5		
		72	SHC	129.9	168.5	207.1	124.5	163.0	201.5	118.7	157.1	195.5	112.5	150.8	189.2		
		76	THC	-	358.2	358.2	-	342.4	342.4	-	325.4	325.4	-	307.1	307.1		
		76	SHC	-	137.0	178.2	-	131.7	172.9	-	126.0	166.9	-	119.9	160.4		
		8,750 CFM	EAT (wb)	58	THC	278.2	278.2	314.5	267.8	267.8	302.8	256.5	256.5	289.9	244.2	244.2	276.1
				58	SHC	241.9	278.2	314.5	232.8	267.8	302.8	223.0	256.5	289.9	212.3	244.2	276.1
62	THC			287.2	287.2	308.3	274.3	274.3	301.5	260.8	260.8	291.7	247.0	247.0	280.9		
62	SHC			222.1	265.2	308.3	215.7	258.6	301.5	207.7	249.7	291.7	199.0	240.0	280.9		
67	THC			314.0	314.0	314.0	299.8	299.8	299.8	284.4	284.4	284.4	267.8	267.8	267.8		
67	SHC			179.1	222.7	266.4	173.3	216.9	260.6	167.2	210.8	254.3	160.7	204.2	247.7		
76	72		THC	343.0	343.0	343.0	327.7	327.7	327.7	311.1	311.1	311.1	293.1	293.1	293.1		
	72		SHC	134.3	178.5	222.6	128.8	172.9	216.9	122.9	166.9	210.8	116.6	160.4	204.3		
	76		THC	-	367.3	367.3	-	350.8	350.8	-	333.0	333.0	-	313.8	313.8		
	76		SHC	-	142.6	189.4	-	137.1	183.5	-	131.2	177.3	-	125.0	170.7		
	10,000 CFM		EAT (wb)	58	THC	289.7	289.7	327.5	278.7	278.7	315.0	266.6	266.6	301.4	253.6	253.6	286.7
				58	SHC	251.9	289.7	327.5	242.3	278.7	315.0	231.8	266.6	301.4	220.5	253.6	286.7
62		THC		294.6	294.6	329.6	282.2	282.2	319.7	268.7	268.7	309.1	254.1	254.1	298.4		
62		SHC		234.7	282.1	329.6	226.8	273.3	319.7	218.4	263.7	309.1	209.7	254.1	298.4		
67		THC		320.6	320.6	320.6	305.9	305.9	305.9	289.9	289.9	289.9	272.7	272.7	272.7		
67		SHC		188.6	237.7	286.8	182.7	231.8	280.9	176.5	225.5	274.5	169.8	218.8	267.7		
76		72	THC	350.0	350.0	350.0	334.0	334.0	334.0	316.8	316.8	316.8	298.2	298.2	298.2		
		72	SHC	138.4	187.9	237.5	132.8	182.2	231.7	126.8	176.1	225.5	120.4	169.6	218.8		
		76	THC	-	374.4	374.4	-	357.3	357.3	-	338.7	338.7	-	318.9	318.9		
		76	SHC	-	147.7	199.5	-	142.1	193.7	-	136.1	187.4	-	129.7	180.6		
		11,250 CFM	EAT (wb)	58	THC	299.4	299.4	338.4	287.8	287.8	325.4	275.2	275.2	311.1	261.4	261.4	295.6
				58	SHC	260.3	299.4	338.4	250.2	287.8	325.4	239.2	275.2	311.1	227.3	261.4	295.6
62	THC			302.2	302.2	346.0	289.3	289.3	335.7	275.5	275.5	323.5	262.1	262.1	307.7		
62	SHC			244.8	295.4	346.0	236.7	286.2	335.7	227.5	275.5	323.5	216.4	262.1	307.7		
67	THC			325.9	325.9	325.9	310.7	310.7	310.7	294.2	294.2	294.2	276.6	276.6	286.7		
67	SHC			197.6	252.1	306.5	191.7	246.1	300.4	185.3	239.6	293.9	178.5	232.6	286.7		
76	72		THC	355.5	355.5	355.5	339.1	339.1	339.1	321.3	321.3	321.3	302.2	302.2	302.2		
	72		SHC	142.1	197.0	251.8	136.4	191.2	245.9	130.4	185.0	239.6	123.9	178.3	232.8		
	76		THC	-	380.0	380.0	-	362.4	362.4	-	343.3	343.3	-	322.8	322.8		
	76		SHC	-	152.4	209.4	-	146.8	203.4	-	140.7	197.0	-	134.2	190.2		
	12,500 CFM		EAT (wb)	58	THC	307.7	307.7	347.9	295.7	295.7	334.2	282.5	282.5	319.3	268.2	268.2	303.2
				58	SHC	267.6	307.7	347.9	257.1	295.7	334.2	245.6	282.5	319.3	233.2	268.2	303.2
62		THC		308.4	308.4	362.2	295.9	295.9	347.4	283.1	283.1	332.4	268.4	268.4	315.2		
62		SHC		254.6	308.4	362.2	244.4	295.9	347.4	233.8	283.1	332.4	221.7	268.4	315.2		
67		THC		330.2	330.2	330.2	314.6	314.6	319.2	297.8	297.8	312.3	279.8	279.8	304.7		
67		SHC		206.3	265.9	325.5	200.3	259.7	319.2	193.8	253.1	312.3	186.7	245.7	304.7		
76		72	THC	360.1	360.1	360.1	343.2	343.2	343.2	325.0	325.0	325.0	305.4	305.4	305.4		
		72	SHC	145.7	205.7	265.7	139.9	199.8	259.7	133.8	193.5	253.3	127.3	186.8	246.3		
		76	THC	-	384.6	384.6	-	366.5	366.5	-	346.9	346.9	-	325.9	325.9		
		76	SHC	-	157.0	218.9	-	151.2	212.9	-	145.1	206.3	-	138.5	199.3		

Note: See Minimum–Maximum Airflow Ratings in Table 5. Do not operate outside these limits.

LEGEND:

- Do not operate
- Cfm - Cubic feet per minute (supply air)
- EAT(db) - Entering air temperature (dry bulb)
- EAT(wb) - Entering air temperature (wet bulb)
- SHC - Sensible heat capacity
- TC - Total capacity

48TCE29 (25 TONS) – UNIT WITH HUMIDI-MIZER IN SUBCOOLING MODE										
Temp (F) Air Entering Condenser (Edb)		AIR ENTERING EVAPORATOR – CFM								
		7,500			10,000			12,500		
		Air Entering Evaporator – Ewb (F)								
		72	67	62	72	67	62	72	67	62
75	TC	351.3	319.5	287.8	370.4	337.3	304.1	385.8	351.5	317.2
	SHC	166.5	199.4	232.3	191.2	245.6	258.5	211.4	245.6	279.9
	kW	16.75	16.55	15.20	17.30	16.75	15.85	17.80	17.50	16.50
85	TC	327.5	296.4	265.3	346.1	313.6	281.2	361.1	327.5	294.0
	SHC	137.4	178.2	219.0	162.6	204.5	246.4	183.3	226.0	268.7
	kW	18.65	18.45	17.25	19.20	18.65	17.80	19.45	19.15	18.15
95	TC	303.7	273.3	242.9	321.8	290.0	258.3	336.4	303.5	270.7
	SHC	108.2	157.0	205.8	134.0	184.1	234.3	155.1	206.4	257.6
	kW	20.60	20.40	19.34	21.15	20.60	19.95	21.60	21.30	20.30
105	TC	279.9	250.2	220.4	297.5	266.4	235.3	311.7	279.5	247.4
	SHC	79.0	135.8	192.5	105.4	163.8	222.2	127.1	186.7	246.4
	kW	22.85	22.65	21.45	23.40	22.85	22.05	23.70	23.40	22.40
115	TC	256.2	227.1	198.0	273.2	242.8	212.4	287.0	255.5	224.1
	SHC	49.9	114.5	179.2	76.8	143.4	210.1	98.9	167.1	223.8
	kW	25.05	24.85	23.65	25.60	25.05	24.25	25.90	25.60	24.60

48TCE29 (25 TONS) – UNIT WITH HUMIDI-MIZER IN HOT GAS REHEAT MODE										
Temp (F) Air Entering Condenser (Edb)		AIR ENTERING EVAPORATOR – Ewb (F)								
		75 Dry Bulb			75 Dry Bulb			75 Dry Bulb		
		62.5 Wet Bulb			64 Wet Bulb			65.3 Wet Bulb		
		(50% Relative)			(56% Relative)			(60% Relative)		
		Air Entering Evaporator – Cfm								
		7,500	10,000	12,500	7,500	10,000	12,500	7,500	10,000	12,500
80	TC	124.40	133.90	139.00	132.00	142.10	145.10	135.60	149.10	151.50
	SHC	37.60	60.70	82.20	27.80	45.40	65.80	17.50	34.20	50.10
	kW	15.83	15.90	16.00	15.97	16.13	16.16	16.11	16.31	16.38
75	TC	129.00	138.50	144.60	136.60	147.60	150.10	140.60	154.00	156.30
	SHC	47.10	70.60	92.10	37.30	55.30	75.70	27.00	43.70	60.00
	kW	15.77	15.83	15.94	15.91	16.07	16.10	16.05	16.25	16.32
70	TC	133.60	143.10	149.20	141.20	152.30	154.80	145.30	158.80	161.10
	SHC	57.30	80.70	102.20	47.50	65.40	85.80	37.20	53.90	70.10
	kW	15.68	15.75	15.86	15.83	16.00	16.04	15.88	16.08	16.15
60	TC	142.80	158.40	158.40	150.40	161.40	163.90	153.90	167.40	169.70
	SHC	76.50	121.40	121.40	66.70	84.60	105.00	56.40	73.10	89.30
	kW	15.54	15.60	15.71	15.68	15.84	15.87	15.82	16.02	16.09
50	TC	151.80	161.30	167.40	159.40	170.50	173.20	162.80	176.20	178.80
	SHC	94.10	117.50	139.00	84.30	102.20	122.60	74.00	90.70	106.90
	kW	15.40	15.47	15.58	15.54	15.68	15.71	15.66	15.86	15.93
40	TC	161.20	170.70	176.80	168.80	179.80	182.50	172.20	185.70	188.20
	SHC	114.10	137.60	159.10	104.30	122.30	142.70	94.00	110.70	127.00
	kW	15.24	15.31	15.42	15.39	15.55	15.58	15.53	15.73	15.80

LEGEND

- Edb** – Entering Dry–Bulb
- Ewb** – Entering Wet–Bulb
- kW** – Compressor Motor Power Input
- ldb** – Leaving Dry–Bulb
- lwb** – Leaving Wet–Bulb
- SHC** – Sensible Heat Capacity (1000 Btuh) Gross
- TC** – Total Capacity (1000 Btuh) Gross

NOTES:

1. Direct interpolation is permissible. Do not extrapolate.
2. The following formulas may be used:

$$t_{ldb} = t_{edb} - \frac{\text{sensible capacity (Btuh)}}{1.10 \times \text{cfm}}$$

t_{lwb} = Wet–bulb temperature corresponding to enthalpy of air leaving evaporator coil (h_{lwb})

$$h_{lwb} = h_{ewb} - \frac{\text{total capacity (Btuh)}}{4.5 \times \text{cfm}}$$

Where: h_{ewb} = Enthalpy of air entering evaporator coil

STATIC PRESSURE ADDERS (in wg.) - Factory Options and/or Accessories

Humidi-MiZer

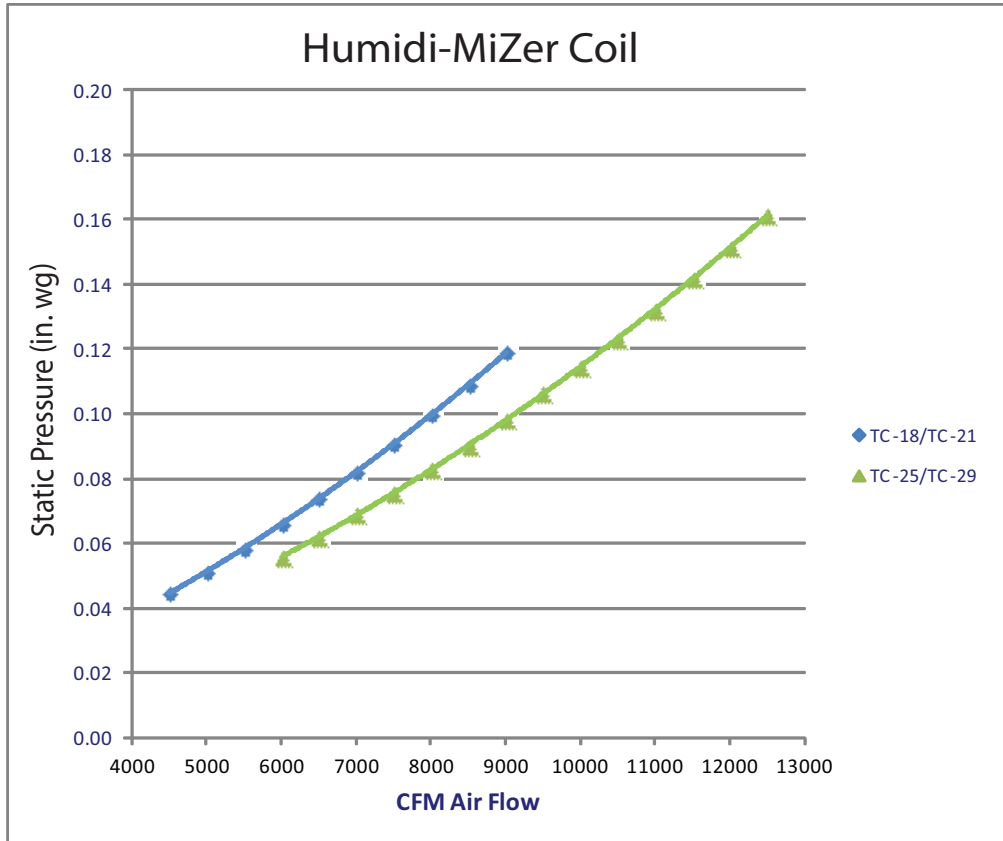

C13822

Economizer - Horizontal Duct Configuration

MODEL SIZES 18-29								
CFM	4500	5000	5500	6000	6500	7000	7500	8000
Static Pressure Adder (in. wg)	0.047	0.052	0.057	0.062	0.067	0.072	0.077	0.082

MODEL SIZES 18-29									
CFM	8500	9000	9500	10000	10500	11000	11500	12000	12500
Static Pressure Adder (in. wg)	0.088	0.093	0.098	0.103	0.109	0.114	0.119	0.125	0.131

DAMPER, BAROMETRIC RELIEF AND PE PERFORMANCE

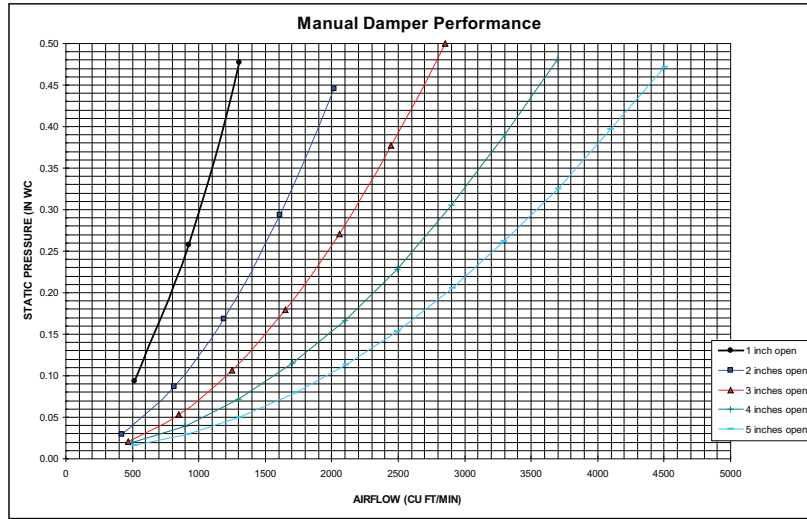

Fig. 9 - Manual Damper Performance

C09264

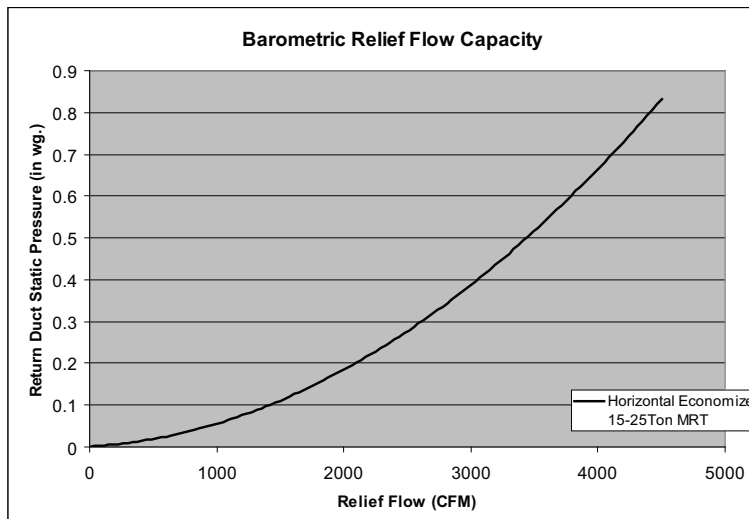

Fig. 10 - Barometric Relief Flow Capacity

C13850

Power Exhaust Fan Performance

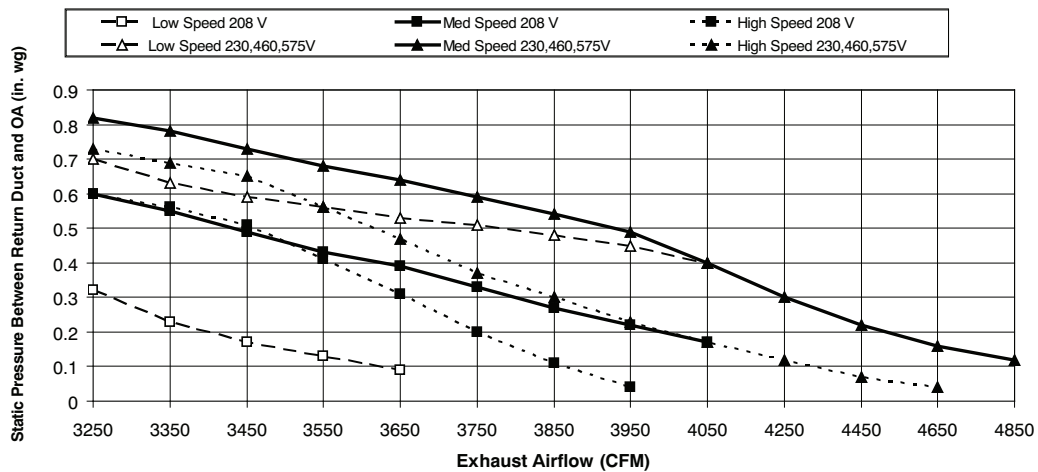

Fig. 11 - Power Exhaust Fan Performance

C11308

GENERAL FAN PERFORMANCE NOTES:

1. Interpolation is permissible. Do not extrapolate.
2. External static pressure is the static pressure difference between the return duct and the supply duct plus the static pressure caused by any FIOPs or accessories.
3. Tabular data accounts for pressure loss due to clean filters, high gas heat, unit casing, and wet coils. Factory options and accessories may add static pressure losses. Selection software is available, through your salesperson, to help you select the best motor/drive combination for your application.
4. The Fan Performance tables offer motor/drive recommendations. In cases when two motor/drive combinations would work, Carrier recommended the lower horsepower option.
5. For information on the electrical properties of Carrier motors, please see the Electrical information section of this book.
6. For more information on the performance limits of Carrier motors, see the application data section of this book.

FAN PERFORMANCE

Table 17 – 48TC*18

HORIZONTAL SUPPLY / RETURN

15 TON

CFM	Available External Static Pressure (in. wg)									
	0.2		0.4		0.6		0.8		1.0	
	RPM	BHP	RPM	BHP	RPM	BHP	RPM	BHP	RPM	BHP
4500	523	1.13	593	1.56	656	2.03	713	2.55	766	3.10
4900	557	1.38	623	1.84	683	2.33	738	2.87	<u>790</u>	<u>3.44</u>
5250	587	1.62	650	2.11	708	2.63	761	3.18	811	3.77
5600	617	1.90	678	2.41	733	2.95	785	3.53	833	4.14
6000	652	2.25	710	2.80	763	3.37	813	3.97	860	4.60
6400	688	2.65	743	3.24	794	3.84	841	4.46	887	5.11
6750	719	3.04	772	3.66	821	4.29	867	4.93	911	5.61
7100	750	3.47	802	4.12	849	4.78	894	5.45	–	–
7500	786	4.01	836	4.70	882	5.39	–	–	–	–
CFM	Available External Static Pressure (in. wg)									
	1.2		1.4		1.6		1.8		2.0	
	RPM	BHP	RPM	BHP	RPM	BHP	RPM	BHP	RPM	BHP
4500	814	3.68	859	4.27	901	4.88	940	5.49	–	–
4900	837	4.05	882	4.67	924	5.31	–	–	–	–
5250	858	4.40	902	5.05	943	5.72	–	–	–	–
5600	879	4.78	922	5.46	–	–	–	–	–	–
6000	904	5.27	947	5.96	–	–	–	–	–	–
6400	930	5.80	–	–	–	–	–	–	–	–
6750	–	–	–	–	–	–	–	–	–	–
7100	–	–	–	–	–	–	–	–	–	–
7500	–	–	–	–	–	–	–	–	–	–
Standard Static Motor and Drive – 514–680 RPM, Max BHP 2.2					Medium Static Motor and Drive – 614–780 RPM, Max BHP 3.3					
High Static Motor and Drive – 746–912 RPM, Max BHP 4.9					– Outside operating range					
<u>Underscore</u> – Field Supplied Drive with High Static Motor					<i>ITALIC</i> – Field Supplied Motor and Drive					

Table 18 – 48TC*21

HORIZONTAL SUPPLY / RETURN

17.5 TON

CFM	Available External Static Pressure (in. wg)									
	0.2		0.4		0.6		0.8		1.0	
	RPM	BHP	RPM	BHP	RPM	BHP	RPM	BHP	RPM	BHP
5250	587	1.62	650	2.11	708	2.63	761	3.18	811	3.77
5700	626	1.98	686	2.51	740	3.05	791	3.63	840	4.25
6100	661	2.35	718	2.91	771	3.48	820	4.09	866	4.73
6500	696	2.76	751	3.36	802	3.96	849	4.59	894	5.25
7000	741	3.34	793	3.99	841	4.63	886	5.30	929	5.99
7500	786	4.01	836	4.70	882	5.39	925	6.09	966	6.81
7900	823	4.60	<u>871</u>	<u>5.34</u>	915	6.06	957	6.79	997	7.54
8300	<u>860</u>	<u>5.26</u>	906	6.03	949	6.79	989	7.55	–	–
8750	901	6.06	946	6.89	–	–	–	–	–	–
CFM	Available External Static Pressure (in. wg)									
	1.2		1.4		1.6		1.8		2.0	
	RPM	BHP	RPM	BHP	RPM	BHP	RPM	BHP	RPM	BHP
5250	858	4.40	902	5.05	943	5.72	983	6.41	1020	7.11
5700	885	4.90	928	5.58	969	6.28	1008	7.01	–	–
6100	911	5.40	953	6.10	993	6.83	1031	7.58	–	–
6500	937	5.94	978	6.67	1017	7.42	–	–	–	–
7000	971	6.71	1010	7.46	–	–	–	–	–	–
7500	1006	7.56	–	–	–	–	–	–	–	–
7900	–	–	–	–	–	–	–	–	–	–
8300	–	–	–	–	–	–	–	–	–	–
8750	–	–	–	–	–	–	–	–	–	–
Standard Static Motor and Drive – 622–822 RPM, Max BHP 3.3					Medium Static Motor and Drive – 713–879 RPM, Max BHP 4.9					
High Static Motor and Drive – 882–1078 RPM, Max BHP 6.5					– Outside operating range					
Boldface – Field Supplied Drive					<i>ITALIC</i> – Field Supplied Motor and Drive					
<u>Underscore</u> – Field Supplied Drive with High Static Motor										

FAN PERFORMANCE (cont.)

Table 19 – 48TC*25

HORIZONTAL SUPPLY / RETURN

20 TON

CFM	Available External Static Pressure (in. wg)									
	0.2		0.4		0.6		0.8		1.0	
	RPM	BHP	RPM	BHP	RPM	BHP	RPM	BHP	RPM	BHP
6000	651	2.25	709	2.78	762	3.35	812	3.96	858	4.60
6500	696	2.77	750	3.33	801	3.94	848	4.57	893	5.24
7000	741	3.37	792	3.96	840	4.60	886	5.27	929	5.97
7500	787	4.05	834	4.67	880	5.34	924	6.05	965	6.78
8000	833	4.83	878	5.48	921	6.18	963	6.92	1003	7.69
8500	879	5.70	922	6.39	963	7.13	1003	7.89	1042	8.69
9000	<u>926</u>	<u>6.69</u>	966	7.41	1006	8.17	–	–	–	–
9500	973	7.78	1011	8.54	–	–	–	–	–	–
10000	–	–	–	–	–	–	–	–	–	–
CFM	Available External Static Pressure (in. wg)									
	1.2		1.4		1.6		1.8		2.0	
	RPM	BHP	RPM	BHP	RPM	BHP	RPM	BHP	RPM	BHP
6000	902	5.25	943	5.93	983	6.62	1021	7.32	1057	8.04
6500	935	5.94	976	6.65	1014	7.38	1051	8.12	1086	8.88
7000	970	6.70	1009	7.44	1046	8.21	–	–	–	–
7500	1005	7.54	1043	8.32	–	–	–	–	–	–
8000	1042	8.48	–	–	–	–	–	–	–	–
8500	–	–	–	–	–	–	–	–	–	–
9000	–	–	–	–	–	–	–	–	–	–
9500	–	–	–	–	–	–	–	–	–	–
10000	–	–	–	–	–	–	–	–	–	–
Standard Static Motor and Drive – 690–863 RPM, Max BHP 4.9					Medium Static Motor and Drive – 835–1021 RPM, Max BHP 6.5					
High Static Motor and Drive – 941–1176 RPM, Max BHP 8.7					– Outside operating range					
Boldface – Field – Supplied Drive					<i>ITALIC</i> – Field Supplied Motor and Drive					
<u>Underscore</u> – Field Supplied Drive with High Static Motor										

Table 20 – 48TC*29

HORIZONTAL SUPPLY / RETURN

25 TON

CFM	Available External Static Pressure (in. wg)									
	0.2		0.4		0.6		0.8		1.0	
	RPM	BHP	RPM	BHP	RPM	BHP	RPM	BHP	RPM	BHP
7500	715	3.12	767	3.68	815	4.28	862	4.90	906	5.58
8000	751	3.65	800	4.25	847	4.87	892	5.53	934	6.21
8500	786	4.24	834	4.86	879	5.51	922	6.19	963	6.90
9000	822	4.88	867	5.53	910	6.21	952	6.91	991	7.64
9500	856	5.57	916	6.25	941	6.95	981	7.68	1020	8.44
10000	890	6.33	932	7.03	973	7.76	1011	8.52	–	–
10500	924	7.14	965	7.87	1004	8.62	–	–	–	–
11000	958	8.01	997	8.70	–	–	–	–	–	–
11500	991	8.94	1029	9.73	–	–	–	–	–	–
CFM	Available External Static Pressure (in. wg)									
	1.2		1.4		1.6		1.8		2.0	
	RPM	BHP	RPM	BHP	RPM	BHP	RPM	BHP	RPM	BHP
7500	948	6.27	988	6.98	1027	7.72	1065	8.49	–	–
8000	975	6.93	1014	7.67	1052	8.43	–	–	–	–
8500	1002	7.64	1041	8.40	–	–	–	–	–	–
9000	1030	8.41	–	–	–	–	–	–	–	–
9500	–	–	–	–	–	–	–	–	–	–
10000	–	–	–	–	–	–	–	–	–	–
10500	–	–	–	–	–	–	–	–	–	–
11000	–	–	–	–	–	–	–	–	–	–
11500	–	–	–	–	–	–	–	–	–	–
Standard Static Motor and Drive – N/A					Medium Static Motor and Drive – 755–923 RPM, Max BHP 6.5					
High Static Motor and Drive – 827–1010 RPM, Max BHP 8.7					– Outside operating range					
Boldface – Field Supplied Drive					<i>ITALIC</i> – Field Supplied Motor and Drive					

FAN PERFORMANCE (cont.)

Table 21 – PULLEY ADJUSTMENT - HORIZONTAL

UNIT	MOTOR/DRIVE COMBO	MOTOR PULLEY TURNS OPEN										
		0	0.5	1	1.5	2	2.5	3	3.5	4	4.5	5
18	Standard Static	680	663	647	630	614	597	580	564	547	531	514
	Medium Static	780	763	747	730	714	697	680	664	647	631	614
	High Static	912	895	879	862	846	829	812	796	779	763	746
21	Standard Static	822	802	782	762	742	722	702	682	662	642	622
	Medium Static	879	862	846	829	813	796	779	763	746	730	713
	High Static	1078	1058	1039	1019	1000	980	960	941	921	902	882
25	Standard Static	863	846	828	811	794	777	759	742	725	707	690
	Medium Static	1021	1002	984	965	947	928	909	891	872	854	835
	High Static	1176	1153	1129	1106	1082	1059	1035	1012	988	965	941
29	Standard Static	N/A	N/A	N/A	N/A	N/A	N/A	N/A	N/A	N/A	N/A	N/A
	Medium Static	923	906	889	873	856	839	822	805	789	772	755
	High Static	1010	992	973	955	937	919	900	882	864	845	827

NOTE: Do not adjust pulley further than 5 turns open.

■ – Factory settings

N/A – Not Available

ELECTRICAL INFORMATION

Legend and Notes

LEGEND:

BRKR	-	Circuit breaker
CO	-	Convenience outlet
DISC	-	Disconnect
FLA	-	Full load amps
LRA	-	Locked rotor amps
MCA	-	Minimum circuit amps
PE	-	Power exhaust
PWRD CO	-	Powered convenient outlet
UNPWR CO	-	Unpowered convenient outlet



NOTES:

1. In compliance with NEC requirements for multimotor and combination load equipment (refer to NEC Articles 430 and 440), the overcurrent protective device for the unit shall be fuse or HACR breaker. Canadian units may be fuse or circuit breaker.

2. Unbalanced 3-Phase Supply Voltage

Never operate a motor where a phase imbalance in supply voltage is greater than 2%. Use the following formula to determine the percentage of voltage imbalance.

$$\% \text{ Voltage Imbalance} = 100 \times \frac{\text{max voltage deviation from average voltage}}{\text{average voltage}}$$

Example: Supply voltage is 230-3-60



AB = 224 v
BC = 231 v
AC = 226 v

$$\begin{aligned} \text{Average Voltage} &= \frac{(224 + 231 + 226)}{3} = \frac{681}{3} \\ &= 227 \end{aligned}$$

Determine maximum deviation from average voltage.

(AB) $227 - 224 = 3 \text{ v}$

(BC) $231 - 227 = 4 \text{ v}$

(AC) $227 - 226 = 1 \text{ v}$

Maximum deviation is 4 v.

Determine percent of voltage imbalance.

$$\begin{aligned} \% \text{ Voltage Imbalance} &= 100 \times \frac{4}{227} \\ &= 1.76\% \end{aligned}$$

This amount of phase imbalance is satisfactory as it is below the maximum allowable 2%.

IMPORTANT: If the supply voltage phase imbalance is more than 2%, contact your local electric utility company immediately.

NOTE: The 2 speed motors are the same efficiency level as the single speed motors.

ELECTRICAL INFORMATION

Table 22 – 2-STAGE COOLING WITH SINGLE SPEED INDOOR FAN MOTOR

15 - 25 TONS

UNIT	V-Ph-Hz	VOLTAGE RANGE		COMP 1		COMP 2		OFM (ea)		IFM		
		MIN	MAX	RLA	LRA	RLA	LRA	WATTS	FLA	TYPE	EFF at Full Load	FLA
48TC**18	208-3-60	187	253	25.0	164	25.0	164	350	1.5	STD	88.6%	8.4
										MED	87.0%	10.6
										HIGH	82.9%	13.6
	230-3-60	187	253	25.0	164	25.0	164	350	1.5	STD	88.6%	8.3
										MED	87.0%	10.6
										HIGH	82.9%	12.7
	460-3-60	414	506	12.8	100	12.8	100	277	0.9	STD	88.6%	4.2
										MED	87.0%	5.3
										HIGH	82.9%	6.4
	575-3-60	518	633	9.6	78	9.6	78	397	0.6	STD	81.1%	2.8
										MED	81.1%	2.8
										HIGH	83.6%	5.6
48TC**21	208-3-60	187	253	27.6	191	25.0	164	350	1.5	STD	87.0%	10.6
										MED	82.9%	13.6
										HIGH-High Eff.	89.5%	17.1
	230-3-60	187	253	27.6	191	25.0	164	350	1.5	STD	87.0%	10.6
										MED	82.9%	12.7
										HIGH-High Eff.	89.5%	17.1
	460-3-60	414	506	12.8	100	12.2	100	277	0.9	STD	87.0%	5.3
										MED	82.9%	6.4
										HIGH-High Eff.	89.5%	8.6
	575-3-60	518	633	9.6	78	9.0	78	397	0.6	STD	81.1%	2.8
										MED	83.6%	5.6
										HIGH-High Eff.	89.5%	7.6
48TC**25	208-3-60	187	253	30.1	225	30.1	225	350	1.5	STD	82.9%	13.6
										MED-High Eff.	89.5%	17.1
										HIGH-High Eff.	91.7%	28.5
	230-3-60	187	253	30.1	225	30.1	225	350	1.5	STD	82.9%	12.7
										MED-High Eff.	89.5%	17.1
										HIGH-High Eff.	91.7%	28.5
	460-3-60	414	506	16.7	114	16.7	114	277	0.9	STD	82.9%	6.4
										MED-High Eff.	89.5%	8.6
										HIGH-High Eff.	91.7%	14.3
	575-3-60	518	633	12.2	80	12.2	80	397	0.6	STD	83.6%	5.6
										MED-High Eff.	89.5%	7.6
										HIGH-High Eff.	91.7%	9.5

See: "Legend and Notes" on page 42.

Size 29 unit is not available with single speed indoor fan motor

ELECTRICAL INFORMATION

Table 23 – 2-STAGE COOLING WITH 2-SPEED INDOOR FAN MOTOR

15 - 25 TONS

UNIT	V-Ph-Hz	VOLTAGE RANGE		COMP 1		COMP 2		OFM (ea)		IFM		
		MIN	MAX	RLA	LRA	RLA	LRA	WATTS	FLA	TYPE	EFF at Full Load	FLA
48TC**18	208-3-60	187	253	25.0	164	25.0	164	350	1.5	STD	85.0%	8.6
										MED	81.5%	10.8
										HIGH	83.6%	13.6
	230-3-60	187	253	25.0	164	25.0	164	350	1.5	STD	85.0%	7.8
										MED	81.5%	9.8
										HIGH	83.6%	12.7
	460-3-60	414	506	12.8	100	12.8	100	277	0.9	STD	85.0%	3.8
										MED	81.5%	4.9
										HIGH	83.6%	6.4
	575-3-60	518	633	9.6	78	9.6	78	397	0.6	STD	81.1%	4.5
										MED	81.1%	4.5
										HIGH	83.6%	6.2
48TC**21	208-3-60	187	253	27.6	191	25.0	164	350	1.5	STD	81.5%	10.8
										MED	83.6%	13.6
										HIGH	89.5%	17.1
	230-3-60	187	253	27.6	191	25.0	164	350	1.5	STD	81.5%	9.8
										MED	83.6%	12.7
										HIGH	89.5%	17.1
	460-3-60	414	506	12.8	100	12.2	100	277	0.9	STD	81.5%	4.9
										MED	83.6%	6.4
										HIGH	89.5%	8.6
	575-3-60	518	633	9.6	78	9.0	78	397	0.6	STD	81.1%	4.5
										MED	83.6%	6.2
										HIGH	89.5%	7.6
48TC**25	208-3-60	187	253	30.1	225	30.1	225	350	1.5	STD	83.6%	13.6
										MED	89.5%	17.1
										HIGH	91.7%	28.5
	230-3-60	187	253	30.1	225	30.1	225	350	1.5	STD	83.6%	12.7
										MED	89.5%	17.1
										HIGH	91.7%	28.5
	460-3-60	414	506	16.7	114	16.7	114	277	0.9	STD	83.6%	6.4
										MED	89.5%	8.6
										HIGH	91.7%	14.3
	575-3-60	518	633	12.2	80	12.2	80	397	0.6	STD	83.6%	6.2
										MED	89.5%	7.6
										HIGH	91.7%	9.5
48TC**29	208-3-60	187	253	48.1	245	33.3	239	350	1.5	MED	89.5%	17.1
										HIGH	91.7%	28.5
	230-3-60	187	253	48.1	245	33.3	239	350	1.5	MED	89.5%	17.1
										HIGH	91.7%	28.5
	460-3-60	414	506	18.6	125	17.9	125	277	0.9	MED	89.5%	8.6
										HIGH	91.7%	14.3
	575-3-60	518	633	14.7	100	12.8	80	397	0.6	MED	89.5%	7.6
										HIGH	91.7%	9.5

See: "Legend and Notes" on page 42.

ELECTRICAL INFORMATION

Table 24 – UNIT WIRE/FUSE OR HACR BREAKER SIZING DATA - SINGLE SPEED INDOOR FAN MOTOR

UNIT	NOM. V-Ph-Hz	IFM TYPE	NO C.O. or UNPWR C.O.												w/ PWRD C.O.													
			NO P.E.						w/ P.E. (pwrd fr/ unit)						NO P.E.						w/ P.E. (pwrd fr/ unit)							
			MCA	MAX FUSE or HACR BRKR	FLA	DISC. SIZE	LRA	MCA	MAX FUSE or HACR BRKR	FLA	DISC. SIZE	LRA	MCA	MAX FUSE or HACR BRKR	FLA	DISC. SIZE	LRA	MCA	MAX FUSE or HACR BRKR	FLA	DISC. SIZE	LRA	MCA	MAX FUSE or HACR BRKR	FLA	DISC. SIZE	LRA	
48TC**18	208/230-3-60	STD	69.2/69.1	90/90	72/72	409	81.0/80.9	100/100	86/86	429	74.0/73.9	90/90	78/78	414	85.8/85.7	100/100	91/91	434										
		MED	71.4	90	75	423	83.2	100	88	443	76.2	100	80	428	88.0	100	94	448										
		HIGH	74.4/73.5	90/90	78/77	425	86.2/85.3	100/100	92/91	445	79.2/78.3	100/100	84/83	430	91.0/90.1	100/100	97/96	450										
	575-3-60	STD	35.7	45	37	242	41.9	50	45	254	37.9	50	40	244	44.1	50	47	256										
		MED	36.8	45	39	249	43.0	50	46	261	39.0	50	41	251	45.2	50	48	263										
		HIGH	37.9	50	40	250	44.1	50	47	262	40.1	50	42	252	46.3	50	50	264										
48TC**21	208/230-3-60	STD	26.2	30	27	184	31	40	33	192	27.9	35	29	186	32.7	40	35	194										
		MED	26.2	30	27	184	31.0	40	33	192	27.9	35	29	186	32.7	40	35	194										
		HIGH	29	35	31	198	33.8	40	36	206	30.7	40	33	200	35.5	45	38	208										
	575-3-60	STD	76.1	100	80	453	87.9	100	93	473	80.9	100	85	458	92.7	100	99	478										
		MED	79.1/78.2	100/100	83/82	455	90.9/90.0	100/100	97/96	475	83.9/83.0	100/100	89/88	460	95.7/94.8	110/110	102/101	480										
		HIGH	82.6	100	87	451	94.4	110	101	471	87.4	100	93	456	99.2	125	106	476										
48TC**25	208/230-3-60	STD	37.1	45	39	251	43.3	50	46	263	39.3	50	42	253	45.5	50	49	265										
		MED	38.2	50	40	252	44.4	50	47	264	40.4	50	43	254	46.6	50	50	266										
		HIGH	40.4	50	43	250	46.6	50	50	262	42.6	50	45	252	48.8	60	52	264										
	575-3-60	STD	26.2	30	27	186	31	40	33	194	27.9	35	29	188	32.7	40	35	196										
		MED	29.0	35	31	200	33.8	40	36	208	30.7	40	33	202	35.5	45	38	210										
		HIGH	31	40	33	198	35.8	45	38	206	32.7	40	35	200	37.5	45	40	208										
48TC**25	208/230-3-60	STD	87.3/86.4	100/100	92/91	550	99.1/98.2	125/125	105/104	570	92.1/91.2	100/100	97/96	555	103.9/103.0	125/125	111/110	575										
		MED	90.8	100	96	546	102.6	125	109	566	95.6	125	101	551	107.4	125	115	571										
		HIGH	102.2	125	109	625	114.0	125	122	645	107.0	125	114	630	118.8	150	128	650										
	575-3-60	STD	47.6	60	50	280	53.8	60	57	292	49.8	60	52	282	56	70	60	294										
		MED	49.8	60	52	278	56.0	70	60	290	52.0	60	55	280	58.2	70	62	292										
		HIGH	55.5	60	59	318	61.7	70	66	330	57.7	70	62	320	63.9	80	69	332										
575-3-60	STD	35.5	45	37	204	40.3	50	43	212	37.2	45	39	206	42	50	45	214											
	MED	37.5	45	40	202	42.3	50	45	210	39.2	50	42	204	44.0	50	47	212											
	HIGH	39.4	50	42	229	44.2	50	47	237	41.1	50	44	231	45.9	50	49	239											

See: "Legend and Notes" on page 42.

ELECTRICAL INFORMATION

Table 25 – UNIT WIRE/FUSE OR HACR BREAKER SIZING DATA WITH FACTORY INSTALLED 2 SPEED INDOOR FAN OPTION

UNIT	NOM. V-Ph-Hz	IFM TYPE	NO C.O. or UNPWR C.O.												w/ PWRD C.O.																							
			NO PE.						w/ P.E. (pwrdr fr/ unit)						NO PE.						w/ P.E. (pwrdr fr/ unit)																	
			MCA	MAX FUSE or HACR BRKR	FLA	DISC. SIZE LRA	MCA	MAX FUSE or HACR BRKR	FLA	DISC. SIZE LRA	MCA	MAX FUSE or HACR BRKR	FLA	DISC. SIZE LRA	MCA	MAX FUSE or HACR BRKR	FLA	DISC. SIZE LRA	MCA	MAX FUSE or HACR BRKR	FLA	DISC. SIZE LRA																
48TC**18	208/230-3-60	STD	69.4/68.6	90/90	73/72	390	81.2/80.4	100/100	86/85	410	78/77	395	86.0/85.2	100/100	92/91	415	48TC**18	460-3-60	STD	35.3	45	37	233	41.5	50	44	245	37.5	50	39	235	43.7	50	47	247			
		MED	71.6/70.6	90/90	75/74	414	83.4/82.4	100/100	89/88	434	81/79	419	88.2/87.2	100/100	94/93	439			48TC**18	575-3-60	MED	36.4	45	38	245	42.6	50	45	257	38.6	50	41	247	44.8	50	48	259	
		HIGH	74.4/73.5	90/90	78/77	425	86.2/85.3	100/100	92/91	445	84/83	430	91.0/90.1	100/100	97/96	450					48TC**18	208/230-3-60	HIGH	37.9	50	40	250	44.1	50	47	262	40.1	50	42	252	46.3	50	50
	STD	27.9	35	29	184	32.7	40	35	192	31	186	34.4	40	37	194	48TC**18	575-3-60	STD	27.9	35			29	184	32.7	40	35	192	31	186	34.4	40	37	194	34.4	40	37	194
	MED	27.9	35	29	184	32.7	40	35	192	31	186	34.4	40	37	194			48TC**18	208/230-3-60	HIGH			29.6	35	31	198	34.4	40	37	206	31.3	40	33	200	36.1	45	39	208
	STD	76.3/75.3	100/100	80/79	444	88.1/87.1	100/100	93/92	464	85/84	449	92.9/91.9	100/100	99/98	469	48TC**18	208/230-3-60			STD	76.3/75.3	100/100	80/79	444	88.1/87.1	100/100	93/92	464	85/84	449	92.9/91.9	100/100	99/98	469				
MED	79.1/78.2	100/100	83/82	455	90.9/90.0	100/100	97/96	475	89/88	460	95.7/94.8	110/110	102/101	480	48TC**21					460-3-60	HIGH	82.6	100	87	451	94.4	110	101	471	87.4	100	93	456	99.2	125	106	476	
STD	36.7	45	39	247	42.9	50	46	259	41	249	45.1	50	48	261		48TC**21	575-3-60	STD	36.7		45	39	247	42.9	50	46	259	41	249	45.1	50	48	261					
MED	38.2	50	40	252	44.4	50	47	264	43	254	46.6	50	50	266				48TC**21	208/230-3-60		HIGH	40.4	50	43	250	46.6	50	50	262	42.6	60	45	252	48.8	60	52	264	
STD	27.9	35	29	186	32.7	40	35	194	35	194	34.4	40	37	196	48TC**21	575-3-60	STD			27.9	35	29	186	32.7	40	35	194	35	194	34.4	40	37	196					
MED	29.6	35	31	200	34.4	40	37	208	40	208	31.3	40	40	210			48TC**21			208/230-3-60	HIGH	31.0	40	33	198	35.8	45	38	206	32.7	40	35	200	37.5	45	40	208	
STD	87.3/86.4	100/100	92/91	550	99.1/98.2	125/125	105/104	570	92.1/91.2	555	103.9/103.0	125/125	111/110	575	48TC**25	460-3-60		STD	87.3/86.4		100/100	92/91	550	99.1/98.2	125/125	105/104	570	92.1/91.2	555	103.9/103.0	125/125	111/110	575					
MED	90.8	100	96	546	102.6	125	109	566	95.6	561	107.4	125	115	571				48TC**25	575-3-60		HIGH	102.2	125	109	625	114.0	125	122	645	107.0	150	114	630	118.8	150	128	650	
STD	47.6	60	50	280	53.8	60	57	292	60	292	49.8	60	60	294	48TC**25	460-3-60	STD			47.6	60	50	280	53.8	60	57	292	49.8	70	52	282	56.0	70	60	292			
MED	49.8	60	52	278	56.0	70	60	290	52.0	290	52.0	70	55	292			48TC**25			208/230-3-60	HIGH	55.5	60	59	318	61.7	70	66	330	57.7	80	62	320	63.9	80	69	332	
STD	36.1	45	38	204	40.9	50	43	212	37.8	212	42.6	50	45	214	48TC**25	575-3-60		STD	36.1		45	38	204	40.9	50	43	212	37.8	50	40	206	42.6	50	45	214			
MED	37.5	45	40	202	42.3	50	45	210	39.2	210	39.2	50	42	212				48TC**25	208/230-3-60		HIGH	39.4	50	42	229	44.2	50	47	237	41.1	50	44	231	45.9	50	49	239	
STD	119.5	150	124	586	131.3	175	137	606	124.3	606	124.3	150	143	611	48TC**29	460-3-60	STD			119.5	150	124	586	131.3	175	137	606	124.3	175	129	591	136.1	175	143	611			
HIGH	130.9	175	137	665	142.7	175	150	685	135.7	685	135.7	175	156	690			48TC**29			575-3-60	HIGH	130.9	175	137	665	142.7	175	150	685	135.7	175	142	670	147.5	175	156	690	
STD	55.2	60	58	304	61.4	70	65	316	57.4	316	57.4	70	61	318	48TC**29	460-3-60		STD	55.2		60	58	304	61.4	70	65	316	57.4	80	61	306	63.6	80	68	318			
MED	60.9	70	65	344	67.1	80	72	356	63.1	356	63.1	80	80	358				48TC**29	575-3-60		HIGH	60.9	70	65	344	67.1	80	72	356	63.1	80	67	346	69.3	80	74	358	
STD	42.4	50	45	226	47.2	60	50	234	44.1	234	44.1	60	46	236	48TC**29	460-3-60	STD			42.4	50	45	226	47.2	60	50	234	44.1	60	46	228	48.9	60	52	236			
HIGH	44.3	50	47	253	49.1	60	52	261	46.0	261	46.0	60	60	263			48TC**29			575-3-60	HIGH	44.3	50	47	253	49.1	60	52	261	46.0	60	49	255	50.8	60	54	263	

See: "Legend and Notes" on page 42.

SEQUENCE OF OPERATION

General

The sequence below describes the sequence of operation for an electro-mechanical unit with and without a factory installed EconoMiSer™ IV and X (called “economizer” in this sequence). For information regarding a direct digital controller, see the start-up, operations, and troubleshooting manual for the applicable controller.

Electro-mechanical units with no economizer

Cooling (Single speed indoor fan motor) —

When the thermostat calls for cooling, terminals G and Y1 are energized. As a result, the indoor-fan contactor (IFC) and the compressor contactor (C1) are energized, causing the indoor-fan motor (IFM), compressor #1, and outdoor fan to start. If the unit has 2 stages of cooling, the thermostat will additionally energize Y2. The Y2 signal will energize compressor contactor #2 (C2), causing compressor #2 to start. Regardless of the number of stages, the outdoor-fan motor runs continuously while unit is cooling.

Cooling (2-speed indoor fan motor) —

Per ASHRAE 90.1 2010 standard section 6.4.3.10.b, during the first stage of cooling operation the VFD will adjust the fan motor to provide 2/3rd of the total cfm established for the unit. When a call for the second stage of cooling is required, the VFD will allow the total cfm for the unit established (100%).

Heating —

NOTE: WeatherMaker (48TC) units have 2 stages of gas heat.

When the thermostat calls for heating, power is sent to W on the Integrated Gas Controller (IGC) board. An LED (light-emitting diode) on the IGC board turns on and remains on during normal operation. A check is made to ensure that the rollout switch and limit switch are closed. If the check was successful, the induced-draft motor is energized, and when its speed is satisfactory, as proven by the “hall effect” sensor, the ignition activation period begins. The burners will ignite within 5 seconds. If the burners do not light, there is a 22-second delay before another 5-second attempt. This sequence is repeated for 15 minutes or until the burners light. If, after the 15 minutes, the burners still have not lit, heating is locked out. To reset the control, break 24-v power to the thermostat.

When ignition occurs, the IGC board will continue to monitor the condition of the rollout switch, the limit switches, the “hall effect” sensor, as well as the flame sensor. Forty-five seconds after ignition occurs, assuming the unit is controlled through a room thermostat set for fan auto, the indoor-fan motor will energize (and the outdoor-air dampers will open to their minimum position). If, for some reason, the over-temperature limit opens prior to the start of the indoor fan blower, the unit will shorten the 45-second delay to 5 seconds less than

the time from initiation of heat to when the limit tripped. Gas will not be interrupted to the burners and heating will continue. Once the fan-on delay has been modified, it will not change back to 45 seconds until power is reset to the control.

On units with 2 stages of heat, when additional heat is required, W2 closes and initiates power to the second stage of the main gas valve. When the thermostat is satisfied, W1 and W2 open and the gas valve closes, interrupting the flow of gas to the main burners.

If the call for W1 lasted less than 1 minute, the heating cycle will not terminate until 1 minute after W1 became active. If the unit is controlled through a room thermostat set for fan auto, the indoor-fan motor will continue to operate for an additional 45 seconds then stop. If the over-temperature limit opens after the indoor motor is stopped, but within 10 minutes of W1 becoming inactive, on the next cycle the time will be extended by 15 seconds. The maximum delay is 3 minutes. Once modified, the fan off delay will not change back to 45 seconds unless power is reset to the control. A LED indicator is provided on the IGC to monitor operation.

Electro-mechanical units with an economizer

Cooling —

When free cooling is not available, the compressors will be controlled by the zone thermostat. When free cooling is available, the outdoor-air damper is modulated by the EconoMiSer IV and X control to provide a 50°F (10°C) to 55°F (13°C) mixed-air temperature into the zone. As the mixed air temperature fluctuates above 55°F (13°C) or below 50°F (10°C) dampers will be modulated (open or close) to bring the mixed-air temperature back within control. If mechanical cooling is utilized with free cooling, the outdoor-air damper will maintain its current position at the time the compressor is started. If the increase in cooling capacity causes the mixed-air temperature to drop below 45°F (7°C), then the outdoor-air damper position will be decreased to the minimum position. If the mixed-air temperature continues to fall, the outdoor-air damper will close. Control returns to normal once the mixed-air temperature rises above 48°F (9°C). The power exhaust fans will be energized and de-energized, if installed, as the outdoor-air damper opens and closes.

If field-installed accessory CO₂ sensors are connected to the EconoMiSer IV and X control, a demand controlled ventilation strategy will begin to operate. As the CO₂ level in the zone increases above the CO₂ setpoint, the minimum position of the damper will be increased proportionally. As the CO₂ level decreases because of the increase in fresh air, the outdoor-air damper will be proportionally closed. For EconoMiSer IV and X operation, there must be a thermostat call for the fan (G). If the unit is occupied and the fan is on, the damper will operate at minimum position. Otherwise, the damper will be closed.

SEQUENCE OF OPERATION (cont.)

When the EconoMi\$er IV and X control is in the occupied mode and a call for cooling exists (Y1 on the thermostat), the control will first check for indoor fan operation. If the fan is not on, then cooling will not be activated. If the fan is on, then the control will open the EconoMi\$er IV and damper to the minimum position.

On the initial power to the EconoMi\$er IV and X control, it will take the damper up to 2-1/2 minutes before it begins to position itself. After the initial power-up, further changes in damper position can take up to 30 seconds to initiate. Damper movement from full closed to full open (or vice versa) will take between 1-1/2 and 2-1/2 minutes. If free cooling can be used as determined from the appropriate changeover command (switch, dry bulb, enthalpy curve, differential dry bulb, or differential enthalpy), then the control will modulate the dampers open to maintain the mixed-air temperature setpoint at 50°F (10°C) to 55°F (13°C). If there is a further demand for cooling (cooling second stage - Y2 is energized), then the control will bring on compressor stage 1 to maintain the mixed-air temperature setpoint. The EconoMi\$er IV and X damper will be open at maximum position. EconoMi\$er IV and X operation is limited to a single compressor.

2-Speed Note: When operating in ventilation mode only, the indoor fan motor will automatically adjust to 2/3rd of the total cfm established.

Heating —

The sequence of operation for the heating is the same as an electromechanical unit with no economizer. The only difference is how the economizer acts. The economizer will stay at the Economizer Minimum Position while the evaporator fan is operating. The outdoor-air damper is closed when the indoor fan is not operating.

Refer to Service and Maintenance Manual for further details.

Optional Humidi-MiZer Dehumidification System

Units with the factory equipped Humidi-MiZer option are capable of providing multiple modes of improved dehumidification as a variation of the normal cooling cycle. The Humidi-MiZer option includes additional valves in the liquid line and discharge line of each refrigerant circuit, a small reheat condenser coil downstream of the evaporator, and Motormaster variable-speed control of some or all outdoor fans. Operation of the revised refrigerant circuit for each mode is described below.

The Humidi-MiZer system provides three sub-modes of operation: Cool, Reheat1, and Reheat2.

Cool mode - provides a normal ratio of Sensible and Latent Cooling effect from the evaporator coil.

Reheat1 - provides increased Latent Cooling while slightly reducing the Sensible Cooling effect.

Reheat2 - provides normal Latent Cooling but with null or minimum Sensible Cooling effect delivered to the space.

The Reheat1 and Reheat2 modes are available when the unit is not in a Heating mode and when the Low Ambient Lockout switch is closed.

SEQUENCE OF OPERATION (cont.)

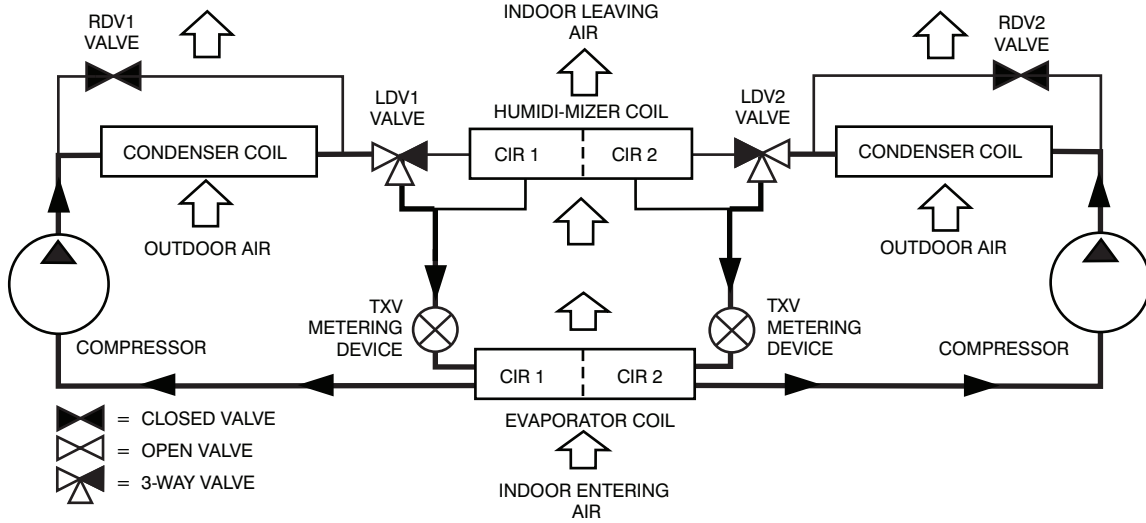

C13792

Normal Cooling Mode - Humidi-MiZer System

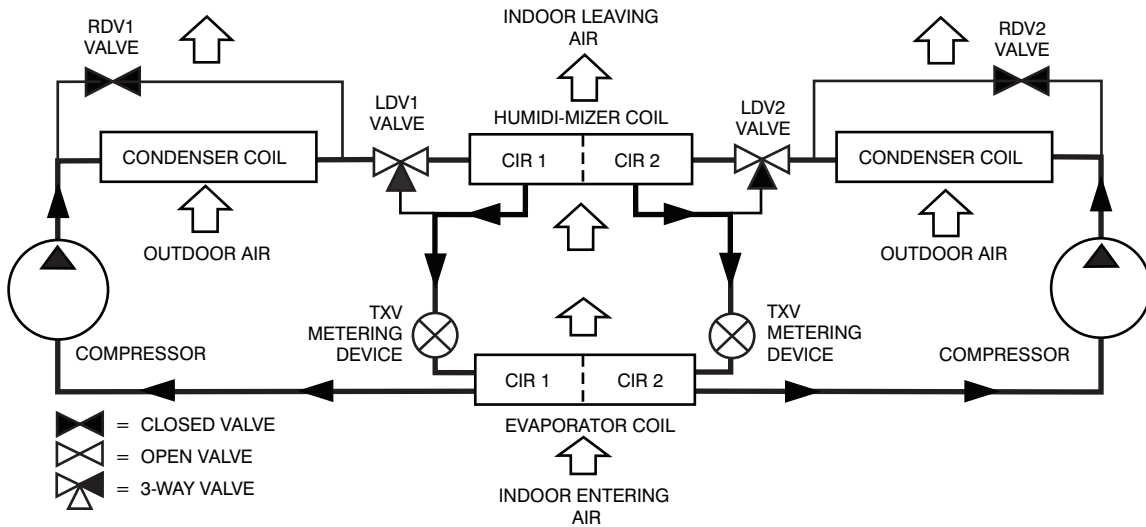

C13809

Subcooling Mode (Reheat 1) - Humidi-MiZer System

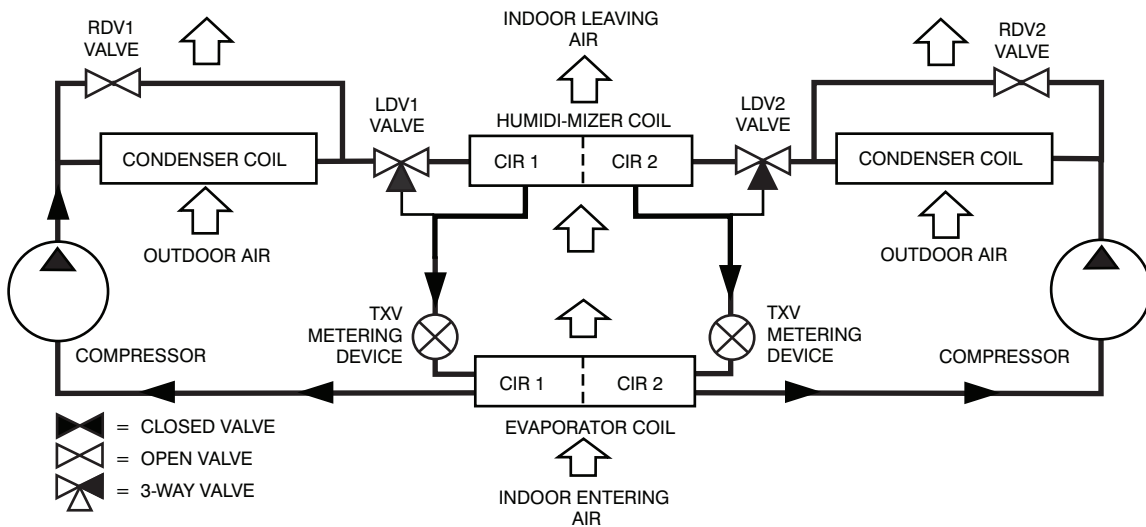

C13793

Hot Gas Reheat Mode (Reheat 2) - Humidi-MiZer System

GUIDE SPECIFICATIONS - 48TC*18-29

Note about this specification:

These specifications are written in “Masterformat” as published by the Construction Specification Institute. Please feel free to copy this specification directly into your building spec.

Gas Heat/Electric Cooling Packaged Rooftop

HVAC Guide Specifications



Size Range: 15 to 25 Nominal Tons

<u>Section</u>	<u>Description</u>
----------------	--------------------

23 06 80	Schedules for Decentralized HVAC Equipment
-----------------	---

- | | |
|----------------|---|
| 23 06 80.13 | Decentralized Unitary HVAC Equipment Schedule |
| 23 06 80.13.A. | Rooftop unit schedule |
| 1. | Schedule is per the project specification requirements. |

23 07 16	HVAC Equipment Insulation
-----------------	----------------------------------

- | | |
|----------------|---|
| 23 07 16.13 | Decentralized, Rooftop Units: |
| 23 07 16.13.A. | Evaporator fan compartment: |
| 1. | Interior cabinet surfaces shall be insulated with a minimum 1/2-in. thick, minimum 1 1/2 lb density, flexible fiberglass insulation bonded with a phenolic binder, neoprene coated on the air side. |
| 2. | Insulation and adhesive shall meet NFPA 90A requirements for flame spread and smoke generation. |
| 23 07 16.13.B. | Gas heat compartment: |
| 1. | Aluminum foil-faced fiberglass insulation shall be used. |
| 2. | Insulation and adhesive shall meet NFPA 90A requirements for flame spread and smoke generation. |

23 09 13	Instrumentation and Control Devices for HVAC
-----------------	---

- | | |
|----------------|---|
| 23 09 13.23 | Sensors and Transmitters |
| 23 09 13.23.A. | Thermostats |
| 1. | Thermostat must |
| a. | energize both “W” and “G” when calling for heat. |
| b. | have capability to energize 2 different stages of cooling, and 2 different stages of heating. |
| c. | include capability for occupancy scheduling. |

23 09 23	Direct-digital Control system for HVAC
-----------------	---

- | | |
|----------------|---|
| 23 09 23.13 | Decentralized, Rooftop Units: |
| 23 09 23.13.A. | PremierLink controller |
| 1. | Shall be ASHRAE 62-2001 compliant. |
| 2. | Shall accept 18-32 VAC input power. |
| 3. | Shall have an operating temperature range from -40°F (-40°C) to 158°F (70°C), 10% - 95% RH (non-condensing). |
| 4. | Shall include an integrated economizer controller to support an economizer with 4 to 20 mA actuator input and no microprocessor controller. |
| 5. | Controller shall accept the following inputs: space temperature, setpoint adjustment, outdoor air temperature, indoor air quality, outdoor air quality, indoor relative humidity, compressor lock-out, fire shutdown, enthalpy, fan status, remote time clock/door switch. |
| 6. | Shall accept a CO ₂ sensor in the conditioned space, and be Demand Control Ventilation (DCV) ready. |
| 7. | Shall provide the following outputs: economizer, fan, cooling stage 1, cooling stage 2, heat stage 1, heat stage 2, heat stage 3/ exhaust/ reversing valve/ dehumidify/ occupied. |
| 8. | Unit shall provide surge protection for the controller through a circuit breaker. |
| 9. | Shall be Internet capable, and communicate at a Baud rate of 38.4K or faster |
| 10. | Shall have an LED display independently showing the status of activity on the communication bus, and processor operation. |
| 11. | Shall include an EIA-485 protocol communication port, an access port for connection of either a computer or a Carrier technician tool, an EIA-485 port for network communication to intelligent space sensors and displays, and a port to connect an optional LonWorks plug-in communications card. |
| 12. | Shall have built-in Carrier Comfort Network (CCN) protocol, and be compatible with other CCN devices, including ComfortVIEW controllers. |

13. Shall have built-in support for Carrier technician tool.
14. Software upgrades will be accomplished by local download. Software upgrades through chip replacements are not allowed.
15. Shall be shock resistant in all planes to 5G peak, 11ms during operation, and 100G peak, 11ms during storage.
16. Shall be vibration resistant in all planes to 1.5G @ 20-300 Hz.
17. Shall support a bus length of 4000 ft (1219m) max, 60 devices per 1000 ft (305m) section, and 1 RS-485 repeater per 1000 ft (305m) sections.

23 09 23.13.B. RTU Open protocol, direct digital controller:

1. Shall be ASHRAE 62-2001 compliant.
2. Shall accept 18-30VAC, 50-60Hz, and consumer 15VA or less power.
3. Shall have an operating temperature range from -40°F (-40°C) to 130°F (54°C), 10% - 90% RH (non-condensing).
4. Shall include built-in protocol for BACNET (MS/TP and PTP modes), Modbus (RTU and ASCII), Johnson N2 and LonWorks. LonWorks Echelon processor required for all Lon applications shall be contained in separate communication board.
5. Shall allow access of up to 62 network variables (SNVT). Shall be compatible with all open controllers
6. Baud rate Controller shall be selectable using a dipswitch.
7. Shall have an LED display independently showing the status of serial communication, running, errors, power, all digital outputs, and all analog inputs.
8. Shall accept the following inputs: space temperature, setpoint adjustment, outdoor air temperature, indoor air quality, outdoor air quality, compressor lock-out, fire shutdown, enthalpy switch, and fan status/filter status/humidity/ remote occupancy.
9. Shall provide the following outputs: economizer, fan, cooling stage 1, cooling stage 2, heat stage 1, heat stage 2, heat stage 3/ exhaust/ reversing valve.
10. Shall have built-in surge protection circuitry through solid state polyswitches. Polyswitches shall be used on incoming power and network connections. Polyswitches will return to normal when the “trip” condition clears.
11. Shall have a battery back-up capable of a minimum of 10,000 hours of data and time clock retention during power outages.
12. Shall have built-in support for Carrier technician tool.
13. Shall include an EIA-485 protocol communication port, an access port for connection of either a computer or a Carrier technician tool, an EIA-485 port for network communication to intelligent space sensors and displays, and a port to connect an optional LonWorks communications card.
14. Software upgrades will be accomplished by either local or remote download. No software upgrades through chip replacements are allowed.

23 09 33 Electric and Electronic Control System for HVAC

23 09 33.13 Decentralized, Rooftop Units:

23 09 33.13.A. General:

1. Shall be complete with self-contained low-voltage control circuit protected by a resettable circuit breaker on the 24-v transformer side. Transformer shall have 75VA capability.
2. Shall utilize color-coded wiring.
3. Shall include a central control terminal board to conveniently and safely provide connection points for vital control functions such as: smoke detectors, phase monitor, gas controller, economizer, thermostat, DDC control options, and low and high pressure switches.
4. The heat exchanger shall be controlled by an integrated gas controller (IGC) microprocessor. See heat exchanger section of this specification.
5. Unit shall include a minimum of one 8-pin screw terminal connection board for connection of control wiring.

23 09 33.23.B. Safeties:

1. Compressor over-temperature, over-current. High internal pressure differential.
2. Low-pressure switch.
 - a. Units shall have different sized connectors for the circuit 1 and circuit 2 low and high pressure switches. They shall physically prevent the cross-wiring of the safety switches between circuits 1 and 2.
 - b. Low pressure switch shall use different color wire than the high pressure switch. The purpose is to assist the installer and service technician to correctly wire and or troubleshoot the rooftop unit.
3. High-pressure switch.
 - a. Units shall have different sized connectors for the circuit 1 and circuit 2 low and high pressure switches. They shall physically prevent the cross-wiring of the safety switches between circuits 1 and 2.

- b. High pressure switch shall use different color wire than the low pressure switch. The purpose is to assist the installer and service technician to correctly wire and or troubleshoot the rooftop unit.
- 4. Automatic reset, motor thermal overload protector.
- 5. Heating section shall be provided with the following minimum protections:
 - a. High-temperature limit switches.
 - b. Induced draft motor speed sensor.
 - c. Flame rollout switch.
 - d. Flame proving controls.

23 09 93 Sequence of Operations for HVAC Controls

23 09 93.13 Decentralized, Rooftop Units:

23 09 93.13 INSERT SEQUENCE OF OPERATION

23 40 13 Panel Air Filters

23 40 13.13 Decentralized, Rooftop Units:

23 40 13.13.A. Standard filter section

- 1. Shall consist of factory-installed, low velocity, disposable 2-in. thick fiberglass filters of commercially available sizes.
- 2. Unit shall use only one filter size. Multiple sizes are not acceptable.
- 3. Filters shall be accessible through a dedicated, weather tight access panel.
- 4. 4-in filter capabilities shall be capable with pre-engineered and approved Carrier filter track field installed accessory. This kit requires field furnished filters.

23 81 19 Self-Contained Air Conditioners

23 81 19.13 Medium-Capacity Self-Contained Air Conditioners

23 81 19.13.A. General

- 1. Outdoor, rooftop mounted, electrically controlled, heating and cooling unit utilizing a fully hermetic scroll compressor(s) for cooling duty and gas combustion for heating duty.
- 2. Factory assembled, single-piece heating and cooling rooftop unit. Contained within the unit enclosure shall be all factory wiring, piping, controls, and special features required prior to field start-up.
- 3. Unit shall use environmentally sound, Puron refrigerant.
- 4. Unit shall be installed in accordance with the manufacturer's instructions.
- 5. Unit must be selected and installed in compliance with local, state, and federal codes.

23 81 19.13.B. Quality Assurance

- 1. Unit meets ASHRAE 90.1 minimum efficiency requirements.
- 2. Units are Energy Star certified where sizes are required.
- 3. Unit shall be rated in accordance with AHRI Standard 340/360.
- 4. Unit shall be designed to conform to ASHRAE 15.
- 5. Unit shall be ETL-tested and certified in accordance with ANSI Z21.47 Standards and ETL-listed and certified under Canadian standards as a total package for safety requirements.
- 6. Insulation and adhesive shall meet NFPA 90A requirements for flame spread and smoke generation.
- 7. Unit casing shall be capable of withstanding 500-hour salt spray exposure per ASTM B117 (scribed specimen).
- 8. Unit casing shall be capable of withstanding Federal Test Method Standard No. 141 (Method 6061) 5000-hour salt spray.
- 9. Unit shall be designed and manufactured in accordance with ISO 9001.
- 10. Roof curb shall be designed to conform to NRCA Standards.
- 11. Unit shall be subjected to a completely automated run test on the assembly line. The data for each unit will be stored at the factory, and must be available upon request.
- 12. Unit shall be designed in accordance with UL Standard 1995, ETL listed including tested to withstand rain.
- 13. Unit shall be constructed to prevent intrusion of snow and tested to prevent snow intrusion into the control box up to 40 mph.
- 14. Unit shake tested to assurance level 1, ASTM D4169 to ensure shipping reliability.
- 15. High Efficient Motors listed shall meet section 313 of the Energy Independence and Security Act of 2007 (EISA 2007).

23 81 19.13.C. Delivery, Storage, and Handling

- 1. Unit shall be stored and handled per manufacturer's recommendations.
- 2. Lifted by crane requires either shipping top panel or spreader bars.

3. Unit shall only be stored or positioned in the upright position.

23 81 19.13.D. Project Conditions

1. As specified in the contract.

23 81 19.13.E. Operating Characteristics

1. Unit shall be capable of starting and running at 115°F (46°C) ambient outdoor temperature, meeting maximum load criteria of AHRI Standard 340/360 at ± 10% voltage.
2. Compressor with standard controls shall be capable of operation down to 35°F (2°C), ambient outdoor temperatures. Accessory winter start kit is necessary if mechanically cooling at ambient temperatures below 35°F (2°C).
3. Unit shall discharge supply air horizontally as shown on contract drawings.
4. Unit shall be factory furnished for horizontal configuration. No field conversion is required.

23 81 19.13.F. Electrical Requirements

1. Main power supply voltage, phase, and frequency must match those required by the manufacturer.

23 81 19.13.G. Unit Cabinet

1. Unit cabinet shall be constructed of galvanized steel, and shall be bonderized and coated with a pre-painted baked enamel finish on all externally exposed surfaces.
2. Unit cabinet exterior paint shall be: film thickness, (dry) 0.003 inches minimum, gloss (per ASTM D523, 60°F / 16°C): 60, Hardness: H-2H Pencil hardness.
3. Evaporator fan compartment interior cabinet insulation shall conform to AHRI Standard 340/360 minimum exterior sweat criteria. Interior surfaces shall be insulated with a minimum 1/2-in. thick, 1 lb density, flexible fiberglass insulation, neoprene coated on the air side.
4. Base of unit shall have a minimum of four locations for thru-the-base gas and electrical connections standard. Both gas and electric connections shall be internal to the cabinet to protect from environmental issues.
5. Base Rail
 - a. Unit shall have base rails on a minimum of 2 sides.
 - b. Holes shall be provided in the base rails for rigging shackles to facilitate maneuvering and overhead rigging.
 - c. Holes shall be provided in the base rail for moving the rooftop by fork truck.
 - d. Base rail shall be a minimum of 16 gauge thickness.
6. Condensate pan and connections:
 - a. Shall be a sloped condensate drain pan made of a non-corrosive material.
 - b. Shall comply with ASHRAE Standard 62.
 - c. Shall use a 3/4-in -14 NPT drain connection, through the side of the drain pan. Connection shall be made per manufacturer's recommendations.
7. Top panel:
 - a. Shall be a multi-piece top panel linked with water tight flanges and locking systems.
8. Gas Connections:
 - a. All gas piping connecting to unit gas valve shall enter the unit cabinet at a single location on side of unit (horizontal plane).
 - b. Thru-the-base capability
 - (1.) Standard unit shall have a thru-the-base gas-line location using a raised, embossed portion of the unit basepan.
 - (2.) Thru-the-base provisions/connections are available as standard with every unit. When bottom connections are required, field furnished couplings are required.
 - (3.) No basepan penetration, other than those authorized by the manufacturer, is permitted.
9. Electrical Connections
 - a. All unit power wiring shall enter unit cabinet at a single, factory-prepared, knockout location.
 - b. Thru-the-base capability
 - (1.) Thru-the-base provisions/connections are available as standard with every unit. When bottom connections are required, field furnished couplings are required.
 - (2.) No basepan penetration, other than those authorized by the manufacturer, is permitted.
10. Component access panels (standard)
 - a. Cabinet panels shall be easily removable for servicing.
 - b. Unit shall have one factory installed, removable, filter access panel.
 - c. Panels covering control box and filter shall have molded composite handles while the blower access door shall have an integrated flange for easy removal.
 - d. Handles shall be UV modified, composite. They shall be permanently attached, and recessed into the panel.

- e. Screws on the vertical portion of all removable access panel shall engage into heat resistant, molded composite collars.
- f. Collars shall be removable and easily replaceable using manufacturer recommended parts.

23 81 19.13.H. Gas Heat

1. General
 - a. Heat exchanger shall be an induced draft design. Positive pressure heat exchanger designs shall not be allowed.
 - b. Shall incorporate a direct-spark ignition system and redundant main gas valve.
 - c. Gas supply pressure at the inlet to the rooftop unit gas valve must match that required by the manufacturer.
2. The heat exchanger shall be controlled by an integrated gas controller (IGC) microprocessor.
 - a. IGC board shall notify users of fault using an LED (light-emitting diode).
 - b. The LED shall be visible without removing the control box access panel.
 - c. IGC board shall contain algorithms that modify evaporator-fan operation to prevent future cycling on high temperature limit switch.
 - d. Unit shall be equipped with anti-cycle protection with one short cycle on unit flame rollout switch or 4 continuous short cycles on the high temperature limit switch. Fault indication shall be made using an LED.
3. Standard Heat Exchanger construction
 - a. Heat exchanger shall be of the tubular-section type constructed of a minimum of 20-gauge steel coated with a nominal 1.2 mil aluminum-silicone alloy for corrosion resistance.
 - b. Burners shall be of the in-shot type constructed of aluminum-coated steel.
 - c. Burners shall incorporate orifices for rated heat output up to 2000 ft (610m) elevation. Additional accessory kits may be required for applications above 2000 ft (610m) elevation, depending on local gas supply conditions.
 - d. Each heat exchanger tube shall contain multiple dimples for increased heating effectiveness.
4. Optional Stainless Steel Heat Exchanger construction
 - a. Use energy saving, direct-spark ignition system.
 - b. Use a redundant main gas valve.
 - c. Burners shall be of the in-shot type constructed of aluminum-coated steel.
 - d. All gas piping shall enter the unit cabinet at a single location on side of unit (horizontal plane).
 - e. The optional stainless steel heat exchanger shall be of the tubular-section type, constructed of a minimum of 20-gauge type 409 stainless steel.
 - f. Type 409 stainless steel shall be used in heat exchanger tubes and vestibule plate.
 - g. Complete stainless steel heat exchanger allows for greater application flexibility.
5. Induced draft combustion motor and blower
 - a. Shall be a direct-drive, single inlet, forward-curved centrifugal type.
 - b. Shall be made from steel with a corrosion-resistant finish.
 - c. Shall have permanently lubricated sealed bearings.
 - d. Shall have inherent thermal overload protection.
 - e. Shall have an automatic reset feature.

23 81 19.13.I. Coils

1. Standard Aluminum Fin/Copper Tube Coils:
 - a. Standard evaporator and condenser coils shall have aluminum lanced plate fins mechanically bonded to seamless internally grooved copper tubes with all joints brazed.
 - b. Evaporator coils shall be leak tested to 150 psig, pressure tested to 450 psig, and qualified to UL 1995 burst test at 1775 psig.
 - c. Condenser coils shall be leak tested to 150 psig, pressure tested to 650 psig, and qualified to UL 1995 burst test at 1980 psig.
2. Optional Pre-coated aluminum-fin condenser coils:
 - a. Shall have a durable epoxy-phenolic coating to provide protection in mildly corrosive coastal environments.
 - b. Coating shall be applied to the aluminum fin stock prior to the fin stamping process to create an inert barrier between the aluminum fin and copper tube.
 - c. Epoxy-phenolic barrier shall minimize galvanic action between dissimilar metals.
3. Optional Copper-fin evaporator and condenser coils:
 - a. Shall be constructed of copper fins mechanically bonded to copper tubes and copper tube sheets.
 - b. Galvanized steel tube sheets shall not be acceptable.
 - c. A polymer strip shall prevent coil assembly from contacting the sheet metal coil pan to minimize potential for galvanic corrosion between coil and pan.

4. Optional E-coated aluminum-fin, aluminum tube condenser coils:
 - a. Shall have a flexible epoxy polymer coating uniformly applied to all coil external surface areas without material bridging between fins.
 - b. Coating process shall ensure complete coil encapsulation, including all exposed fin edges.
 - c. E-coat thickness of 0.8 to 1.2 mil with top coat having a uniform dry film thickness from 1.0 to 2.0 mil on all external coil surface areas, including fin edges, shall be provided.
 - d. Shall have superior hardness characteristics of 2H per ASTM D3363-00 and cross-hatch adhesion of 4B-5B per ASTM D3359-02.
 - e. Shall have superior impact resistance with no cracking, chipping or peeling per NSF/ANSI 51-2002 Method 10.2.

23 81 19.13.J. Refrigerant Components

1. Refrigerant circuit shall include the following control, safety, and maintenance features:
 - a. Thermostatic Expansion Valve (TXV) shall help provide optimum performance across the entire operating range. Shall contain removable power element to allow change out of power element and bulb without removing the valve body.
 - b. Refrigerant filter drier - Solid core design.
 - c. Service gauge connections on suction and discharge lines.
 - d. Pressure gauge access through a specially designed access screen on the side of the unit.
2. Compressors
 - a. Unit shall use fully hermetic, scroll compressor for each independent refrigeration circuit.
 - b. Models shall be available with 2 compressor/2-stage cooling.
 - c. Compressor motors shall be cooled by refrigerant gas passing through motor windings.
 - d. Compressors shall be internally protected from high discharge temperature conditions.
 - e. Compressors shall be protected from an over-temperature and over-amperage conditions by an internal, motor overload device.
 - f. Compressor shall be factory mounted on rubber grommets.
 - g. Compressor motors shall have internal line break thermal, current overload and high pressure differential protection.
 - h. Crankcase heaters shall not be required for normal operating range, unless provided by the factory.

23 81 19.13.K. Filter Section

1. Filters access is specified in the unit cabinet section of this specification.
2. Filters shall be held in place by a preformed, slide-out filter tray, facilitating easy removal and installation.
3. Shall consist of factory-installed, low velocity, throw-away 2-in. thick fiberglass filters.
4. Filters shall be standard, commercially available sizes.
5. Only one size filter per unit is allowed.
6. 4-in filter capability is possible with a field installed pre-engineered slide out filter track accessory. 4-in filters are field furnished.

23 81 19.13.L. Evaporator Fan and Motor

1. Evaporator fan motor:
 - a. Shall have inherent automatic-reset thermal overload protection or circuit breaker.
 - b. Shall have a maximum continuous bhp rating for continuous duty operation; no safety factors above that rating shall be required.
2. Belt-driven Evaporator Fan:
 - a. Belt drive shall include an adjustable-pitch motor pulley and belt break protection system.
 - b. Shall use rigid pillow block bearing system with lubricant fittings at accessible bearing or lubrication line.
 - c. Blower fan shall be double-inlet type with forward-curved blades.
 - d. Shall be constructed from steel with a corrosion resistant finish and dynamically balanced.
 - e. Standard on all 18-29 size Humidi-MiZer models.

23 81 19.13.M. Condenser Fans and Motors

1. Condenser fan motors:
 - a. Shall be a totally enclosed motor.
 - b. Shall use permanently lubricated bearings.
 - c. Shall have inherent thermal overload protection with an automatic reset feature.
 - d. Shall use a shaft-down design.

2. Condenser Fans:
 - a. Shall be a direct-driven propeller type fan.
 - b. Shall have aluminum blades riveted to corrosion-resistant steel spiders and shall be dynamically balanced.

23 81 19.13.N. Special Features Options and Accessories

1. Staged Air Volume System (SAV) for 2-stage cooling models only:
 - a. Evaporator fan motor:
 - (1.) Shall have permanently lubricated bearings.
 - (2.) Shall have a maximum continuous bhp rating for continuous duty operation; no safety factors above that rating.
 - (3.) Shall be Variable Frequency duty and 2-speed control.
 - (4.) Shall contain motor shaft grounding ring to prevent electrical bearing fluting damage by safely diverting harmful shaft voltages and bearing currents to ground.
2. Variable Frequency Drive (VFD). Only available on 2-speed indoor fan motor option (SAV):
 - a. Shall be installed inside the unit cabinet, mounted, wired and tested.
 - b. Shall contain Electromagnetic Interference (EMI) frequency protection.
 - c. Insulated Gate Bi-Polar Transistors (IGBT) used to produce the output pulse width modulated (PWM) waveform, allowing for quiet motor operation.
 - d. Self diagnostics with fault and power code LED indicator. Field accessory Display Kit available for further diagnostics and special setup applications.
 - e. RS485 capability standard.
 - f. Electronic thermal overload protection.
 - g. 5% swinging chokes for harmonic reduction and improved power factor.
 - h. All printed circuit boards shall be conformal coated.
3. Integrated EconoMi\$er IV and EconoMi\$er 2, and EconoMi\$er X **standard leak rate models**. (Factory or field installed):
 - a. Integrated, gear driven opposing modulating blade design type capable of simultaneous economizer and compressor operation.
 - b. Independent modules for horizontal return configuration shall be available.
 - c. Damper blades shall be galvanized steel with composite gears. Plastic or composite blades on intake or return shall not be acceptable.
 - d. Shall include all hardware and controls to provide free cooling with outdoor air when temperature and/or humidity are below setpoints.
 - e. Shall be equipped with gear driven dampers for both the outdoor ventilation air and the return air for positive air stream control.
 - f. Standard leak rate shall be equipped with dampers not to exceed 2% leakage at 1 in. wg pressure differential.
 - g. Economizer controller on EconoMi\$er IV models shall be Honeywell W7212 that provides:
 - (1.) Combined minimum and DCV maximum damper position potentiometers with compressor staging relay.
 - (2.) Functions with solid state analog enthalpy or dry bulb changeover control sensing.
 - (3.) Contain LED indicates for: when free cooling is available, when module is in DCV mode, when exhaust fan contact is closed.
 - h. Economizer controller on EconoMi\$er X models shall be the Honeywell W7220 that provides:
 - (1.) 2-line LCD interface screen for setup, configuration and troubleshooting
 - (2.) On-board Fault Detection and Diagnostics (FDD) that senses and alerts when the economizer is not operating properly, per California Title 24.
 - (3.) Sensor failure loss of communication identification
 - (4.) Automatic sensor detection
 - (5.) Capabilities for use with multiple-speed indoor fan systems
 - (6.) Utilize digital sensors: Dry bulb and Enthalpy
 - i. Economizer controller on EconoMi\$er 2 models with PremierLink shall be 4-20mA design and controlled by the PremierLink controller. PremierLink does not comply with California Title 24 Fault Detection & Diagnostic (FDD) requirements.

- j. Economizer controller on EconoMiSer 2 models with RTU Open models shall be a 4-20mA design controlled directly by the RTU Open controller. RTU Open meets California Title 24 Fault Detection & Diagnostic (FDD) requirements.
 - k. Shall be capable of introducing up to 100% outdoor air.
 - l. Shall be equipped with a barometric relief damper capable of relieving up to 100% return air and contain seals that meet ASHRAE90.1 requirements.
 - m. Shall be designed to close damper(s) during loss-of-power situations with spring return built into motor.
 - n. Dry bulb outdoor air temperature sensor shall be provided as standard. Enthalpy sensor is also available on factory installed only. Outdoor air sensor setpoint shall be adjustable and shall range from 40 to 100°F / 4 to 38°C. Additional sensor options shall be available as accessories.
 - o. The economizer controller shall also provide control of an accessory power exhaust unit function. Factory set at 100%, with a range of 0% to 100%.
 - p. The economizer shall maintain minimum airflow into the building during occupied period and provide design ventilation rate for full occupancy.
 - q. Dampers shall be completely closed when the unit is in the unoccupied mode.
 - r. Economizer controller shall accept a 2-10 Vdc CO2 sensor input for IAQ/DCV control. In this mode, dampers shall modulate the outdoor air damper to provide ventilation based on the sensor input.
 - s. Compressor lockout temperature on W7220 is adjustable from -45°F to 80°F, set at a factory default of 32°F. Others shall open at 35°F (2°C) and closes at 50°F (10°C).
 - t. Actuator shall be direct coupled to economizer gear. No linkage arms or control rods shall be acceptable.
 - u. Economizer controller shall provide indications when in free cooling mode, in the DCV mode, or the exhaust fan contact is closed.
4. **Integrated EconoMiSer2, and EconoMiSer X Ultra Low Leak rate models.** (Factory or field installed)
- a. Integrated, gear driven opposing modulating blade design type capable of simultaneous economizer and compressor operation.
 - b. Independent modules for horizontal return configuration shall be available.
 - c. Damper blades shall be galvanized steel with composite gears. Plastic or composite blades on intake or return shall not be acceptable.
 - d. Shall include all hardware and controls to provide free cooling with outdoor air when temperature and/or humidity are below setpoints.
 - e. Shall be equipped with gear driven dampers for both the outdoor ventilation air and the return air for positive air stream control.
 - f. Ultra Low Leak design meets California Title 24 section 140.4 and ASHRAE90.1 requirements of 4 cfm per sq. ft. on the outside air dampers and 10 cfm per sq. ft. on the return dampers
 - g. Economizer controller on EconoMiSer X models shall be the Honeywell W7220 that provides:..
 - (1.) 2-line LCD interface screen for setup, configuration and troubleshooting
 - (2.) On-board Fault Detection and Diagnostics (FDD) that senses and alerts when the economizer is not operating properly, per California Title 24.
 - (3.) Sensor failure loss of communication identification
 - (4.) Automatic sensor detection
 - (5.) Capabilities for use with multiple-speed indoor fan systems
 - (6.) Utilize digital sensors: Dry bulb and Enthalpy
 - h. Economizer controller on EconoMiSer 2 models with RTU Open models shall be a 4-20mA design controlled directly by the RTU Open controller. RTU Open meets California Title 24 Fault Detection & Diagnostic (FDD) requirements.
 - i. Shall be capable of introducing up to 100% outdoor air.
 - j. Shall be equipped with a barometric relief damper capable of relieving up to 100% return air and contain seals that meet ASHRAE 90.1 requirements.
 - k. Shall be designed to close damper(s) during loss-of-power situations with spring return built into motor.
 - l. Dry bulb outdoor air temperature sensor shall be provided as standard. Enthalpy sensor is also available on factory installed only. Outdoor air sensor setpoint shall be adjustable and shall range from 40 to 100°F / 4 to 38°C. Additional sensor options shall be available as accessories.
 - m. The economizer controller shall also provide control of an accessory power exhaust unit function. Factory set at 100%, with a range of 0% to 100%.
 - n. The economizer shall maintain minimum airflow into the building during occupied period and provide design ventilation rate for full occupancy.

- o. Dampers shall be completely closed when the unit is in the unoccupied mode.
 - p. Economizer controller shall accept a 2-10 Vdc CO2 sensor input for IAQ/DCV control. In this mode, dampers shall modulate the outdoor air damper to provide ventilation based on the sensor input.
 - q. Compressor lockout temperature on W7220 is adjustable from -45°F to 80°F, set at a factory default of 32°F. Others shall open at 35°F (2°C) and closes at 50°F (10°C).
 - r. Actuator shall be direct coupled to economizer gear. No linkage arms or control rods shall be acceptable.
 - s. Economizer controller shall provide indications when in free cooling mode, in the DCV mode, or the exhaust fan contact is closed.
5. Two-Position Motorized Damper:
- a. Damper shall be a 2-position damper. Damper travel shall be from the full closed position to the field adjustable %-open setpoint.
 - b. Damper shall include adjustable damper travel from 25% to 100% (full open).
 - c. Damper shall include single or dual blade, gear driven dampers and actuator motor.
 - d. Actuator shall be direct coupled to damper gear. No linkage arms or control rods shall be acceptable.
 - e. Damper will admit up to 100% outdoor air for applicable rooftop units.
 - f. Damper shall close upon indoor (evaporator) fan shutoff and/or loss of power.
 - g. The damper actuator shall plug into the rooftop unit's wiring harness plug. No hard wiring shall be required.
 - h. Outside air hood shall include aluminum water entrainment filter.
6. Manual damper
- a. Manual damper package shall consist of damper, air inlet screen, and rain hood which can be preset to admit up to 25% outdoor air for year round ventilation.
7. Humidi-MiZer Adaptive Dehumidification System
- a. The Humidi-MiZer Adaptive Dehumidification System shall be factory installed and shall provide greater dehumidification of the occupied space by two modes of dehumidification operations in addition to its normal design cooling mode:
 - (1.) Subcooling mode further sub cools the hot liquid refrigerant leaving the condenser coil when both temperature and humidity in the space are not satisfied.
 - (2.) Hot gas reheat mode shall mix a portion of the hot gas from the discharge of the compressor with the hot liquid refrigerant leaving the condenser coil to create a two-phase heat transfer in the system, resulting in a neutral leaving air temperature when only humidity in the space is not satisfied.
 - (3.) Includes head pressure controller.
8. Head Pressure Control Package (MotorMaster)
- a. Controller shall control coil head pressure by condenser-fan speed modulation or condenser-fan cycling and wind baffles.
 - b. Shall consist of solid-state control and condenser-coil temperature sensor to maintain condensing temperature between 90°F (32°C) and 110°F (43°C) at outdoor ambient temperatures down to -20°F (-29°C).
9. Propane Conversion Kit
- a. Package shall contain all the necessary hardware and instructions to convert a standard natural gas unit for use with liquefied propane. Kits shall be available for elevations from 0 up to 14,000 ft (4,267m).
10. Condenser Coil Hail Guard Assembly
- a. Shall protect against damage from hail.
 - b. Shall be louvered style design.
11. Unit-Mounted, Non-Fused Disconnect Switch:
- a. Switch shall be factory-installed, internally mounted.
 - b. National Electric Code (NEC) and UL approved non-fused switch shall provide unit power shutoff.
 - c. Shall be accessible from outside the unit.
 - d. Shall provide local shutdown and lockout capability.
12. Convenience Outlet:
- a. Powered convenience outlet.
 - (1.) Outlet shall be powered from main line power to the rooftop unit.
 - (2.) Outlet shall be powered from line side of disconnect by installing contractor, as required by code. If outlet is powered from load side of disconnect, unit electrical ratings shall be ETL certified and rated for additional outlet amperage.
 - (3.) Outlet shall be factory-installed and internally mounted with easily accessible 115-v female receptacle.
 - (4.) Outlet shall include 15 amp GFI receptacles with independent fuse protection.

- (5.) Voltage required to operate convenience outlet shall be provided by a factory-installed step-down transformer.
- (6.) Outlet shall be accessible from outside the unit.
- b. Non-Powered convenience outlet.
 - (1.) Outlet shall be powered from a separate 115/120v power source.
 - (2.) A transformer shall not be included.
 - (3.) Outlet shall be factory-installed and internally mounted with easily accessible 115-v female receptacle.
 - (4.) Outlet shall include 15 amp GFI receptacles with independent fuse protection.
 - (5.) Outlet shall be accessible from outside the unit.
- 13. Flue Discharge Deflector:
 - a. Flue discharge deflector shall direct unit exhaust vertically instead of horizontally.
 - b. Deflector shall be defined as a “natural draft” device by the National Fuel and Gas (NFG) code.
- 14. Centrifugal Propeller Power Exhaust:
 - a. Power exhaust shall be used in conjunction with an integrated economizer.
 - b. Independent modules for horizontal return configurations shall be available.
 - c. Horizontal power exhaust shall be mounted in return ductwork.
 - d. Power exhaust shall be controlled by economizer controller operation. Exhaust fans shall be energized when dampers open past the 0-100% adjustable setpoint on the economizer control.
- 15. High Altitude Gas Conversion Kit:
 - a. Package shall contain all the necessary hardware and instructions to convert a standard natural gas unit to operate from 3,000-10,000 ft (914 to 3048m) elevation and 10,001-14,000 ft (3049-4267m) elevation.
- 16. Outdoor Air Enthalpy Sensor:
 - a. The outdoor air enthalpy sensor shall be used to provide single enthalpy control. When used in conjunction with a return air enthalpy sensor, the unit will provide differential enthalpy control. The sensor allows the unit to determine if outside air is suitable for free cooling.
- 17. Return Air Enthalpy Sensor:
 - a. The return air enthalpy sensor shall be used in conjunction with an outdoor air enthalpy sensor to provide differential enthalpy control.
- 18. Indoor Air Quality (CO₂) Sensor:
 - a. Shall be able to provide demand ventilation indoor air quality (IAQ) control.
 - b. The IAQ sensor shall be available in duct mount, wall mount, or wall mount with LED display. The setpoint shall have adjustment capability.
- 19. Smoke detectors:
 - a. Shall be a Four-Wire Controller and Detector.
 - b. Shall be environmental compensated with differential sensing for reliable, stable, and drift-free sensitivity.
 - c. Shall use magnet-activated test/reset sensor switches.
 - d. Shall have tool-less connection terminal access.
 - e. Shall have a recessed momentary switch for testing and resetting the detector.
 - f. Controller shall include:
 - (1.) One set of normally open alarm initiation contacts for connection to an initiating device circuit on a fire alarm control panel.
 - (2.) Two Form-C auxiliary alarm relays for interface with rooftop unit or other equipment.
 - (3.) One Form-C supervision (trouble) relay to control the operation of the Trouble LED on a remote test/reset station.
 - (4.) Capable of direct connection to two individual detector modules.
 - (5.) Can be wired to up to 14 other duct smoke detectors for multiple fan shutdown applications
- 20. Winter start kit
 - a. Shall contain a bypass device around the low pressure switch.
 - b. Shall be required when mechanical cooling is required down to 25°F (-4°C).
 - c. Shall not be required to operate on an economizer when below an outdoor ambient of 40°F (4°C).
- 21. Time Guard
 - a. Shall prevent compressor short cycling by providing a 5-minute delay (±2 minutes) before restarting a compressor after shutdown for any reason.
 - b. One device shall be required per compressor.

22. Barometric Hood (Horizontal Economizer Applications)
 - a. Shall be required when a horizontal economizer and barometric relief are required. Barometric relief damper must be installed in the return air (horizontal) duct work. This hood provides weather protection.
23. Display Kit for Variable Frequency Drive
 - a. Kit allows the ability to access the VFD controller programs to provide special setup capabilities and diagnostics.
 - b. Kit contains display module and communication cable.
 - c. Display Kit can be permanently installed in the unit or used on any SAV system VFD controller as needed.
24. Hinged Access Panels
 - a. Shall provide easy access through hinged access doors with vinyl coated door retainers..
 - b. Shall be on major panels of – filter, control box, and fan motor.
25. Energy Demand System - EDS (field installed accessory):
 - a. Shall utilize wireless network communication to optimize rooftop unit energy usage, up to 875 yds and up to 49 load controllers for each gateway. A wireless cellular signal shall be utilized to communicate energy information to/from the customer web portal.
 - b. Shall utilize explicit algorithms to minimize rooftop electrical demand charges, customizable to each facility
 - c. Shall allow scheduling of rooftop units and provide a “staggered start” approach to minimize electrical consumption charges, customized to each facility
 - d. Scheduling, adjustments, and sub-metered electrical data shall be accessible through a web based customer portal
 - e. Shall provide demand response capability, including compliance with OpenADR protocol
 - f. Shall utilize an external 4-pole relay and an internal single pole relay
 - g. Shall use (2) split core transformers to provide real-time sub-metered electrical usage