

40QAC / 38HDR
40QAQ / 38QRR
Ceiling-Suspended Duct Free Split System
Sizes 018 to 060



Product Data



The ideal compliment to your ducted system when it is impractical or prohibitively expensive to use ductwork.

INDUSTRY LEADING FEATURES / BENEFITS

AN INEXPENSIVE AND CREATIVE SOLUTION TO DESIGN PROBLEMS.

The 38HDR(QRR)/40QAC(QAQ) series duct-free split systems are a matched combination of an outdoor condensing unit and an indoor fan coil unit connected only by refrigerant tubing and wires.

The ceiling-suspended fan coils are ideal for retrofit and modernization projects where it is impractical or prohibitively expensive to run ductwork and where there are no false ceilings or wall space available. This selection of fan coils permits inexpensive and creative solutions to design problems such as:

- Special space requirements such as garages.
- When changes in the load cannot be handled by the existing system like restaurants.
- When adding air conditioning to spaces that are heated by hydronic or electric heat and have no ductwork like schools.
- Historical renovations or any application where preserving the look of the original structure is essential like churches.

These compact indoor fan coil units blend nicely with most ceilings and protrude less than 10 inches (254 mm) from the ceiling. Advanced system components incorporate innovative technology to provide reliable cooling performance at low sound levels.

LOW SOUND LEVELS

When noise is a concern, ceiling-suspended duct-free split systems are the answer. The indoor units are whisper quiet. There are no compressors indoors, either in the conditioned space or directly over it, and there is none of the noise usually generated by air being forced through ductwork.

When sound ordinances and proximity to neighbors demand quiet operation, the 38HDR/QRR unit is the right choice: The advanced, blow-through horizontal airflow design distributes air more evenly over the coil.

SECURE OPERATION

If security is an issue, outdoor and indoor units are connected only by refrigerant piping and wiring to prevent intruders from crawling through ductwork. In addition, since 38HDR/QRR units can be installed close to an outside wall, coils are protected from vandals and severe weather.

FAST INSTALLATION

The small footprint of the outdoor units provide additional benefits. Because they require minimal service and airflow clearances, the outdoor units can be located virtually anywhere - on the ground, roof, balcony, under a deck, or even mounted to an outside wall.

The ceiling-suspended unit has its own mounting bracket for easier installation. Since there is no need to run ductwork and only piping and wiring is required between the indoor and outdoor units, there is minimal disruption to customers in the workplace, making this system ideal for retrofit applications.

SIMPLE SERVICING AND MAINTENANCE

Saving time and money was a big consideration when designing these systems.

On all indoor units, service and maintenance expense is reduced due to easy-to-use cleanable filters and the ability to service the unit from the bottom by removing the filter tracks.

On the outdoor units, a single panel provides immediate access to the isolated compressor and control compartment, allowing a service technician easy access to check the unit operation without a loss of condenser airflow. In addition, the blow-through design of the outdoor section means that dirt accumulates on the inside surface of the coil. Coils can be cleaned from the outside using a pressure hose and mild detergent without removing grilles or using fin combs.

BUILT-IN RELIABILITY

Duct-free split system indoor and outdoor units are designed to provide years of trouble-free operation.

The high wall indoor units include protection against freeze-up.

The condensing units and heat pumps are also protected. There is a three minute time delay before the compressor will start.

An oversized accumulator on heat pumps, high and low pressure switches (loss of pressure switch on heat pumps), and compressor internal overload protection will ensure a robust system that is ideal for light commercial applications.

INDIVIDUAL ROOM COMFORT

Maximum comfort is provided because each space can be controlled individually based on usage pattern. The ceiling-suspended units are equipped with motorized louvers which permits optimal room air mixing to eliminate hot and cold spots for occupant comfort. In addition, year-round comfort can be provided with heat pumps.

ECONOMICAL OPERATION

The duct-free split system design allows individual room heating or cooling when required. There is no need to run large supply-air fans or chilled water pumps to handle a few spaces with unique load patterns. In addition, because air is moved only in the space required, no energy is wasted moving air through ducts.

EASY-TO-USE CONTROLS

The ceiling-suspended units have electro-mechanical controls and can be controlled by one of three user friendly thermostats that mount on the wall.

FLEXIBILITY

A variety of accessories simplify the installation process and help meet system requirements and weather considerations. Available accessories are listed in the *Standard Features and Accessories* section of this document.

AGENCY LISTINGS

All systems are listed with AHRI (Air Conditioning & Refrigeration Institute), and UL.

MODEL NUMBER NOMENCLATURE

INDOOR UNIT

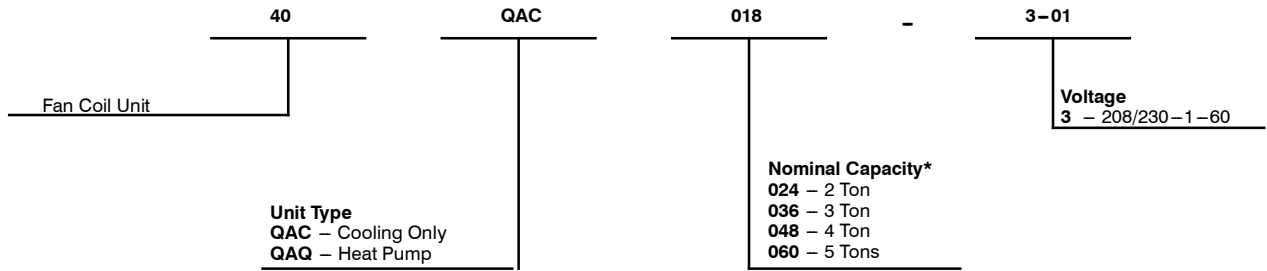

OUTDOOR UNIT

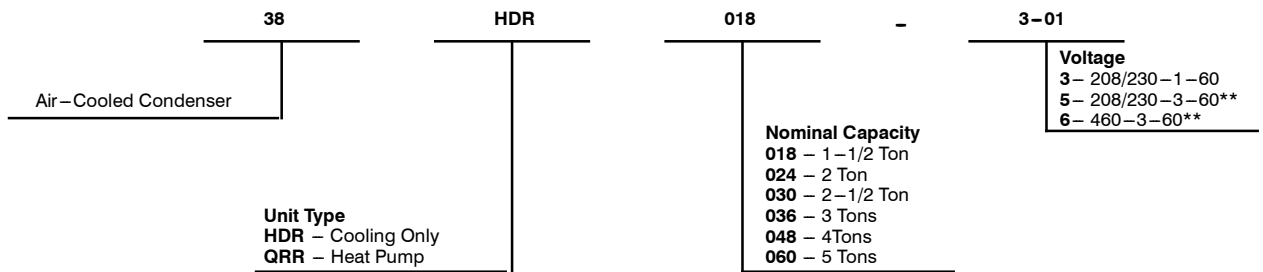

* For nominal size 018 and 030, the indoor unit sizes 024 and 036 are matched with outdoor unit sizes 018 and 030 respectively.
 ** On sizes 036, 048 and 060

40QAC/38HDR – 40QAQ/38QRR



Use of the AHRI Certified TM Mark indicates a manufacturer's participation in the program. For verification of certification for individual products, go to www.ahridirectory.org.



STANDARD FEATURES AND ACCESSORIES

Ease Of Installation	
Compact Size	S
Hanging Bracket For Indoor Unit	S
Stacking Kit	A
Wall Mounting Kit	A
Condensate Pump	A
Comfort Features	
Automatic Air Sweep	S
Auto Restart Function	S
Auto Changeover On Heat Pumps	S
Energy Saving Features	
Stop/Start Timer	S
Safety And Reliability	
3 Minute Time Delay For Compressor	S
Over Current Protection For Compressor	S
High and Low Pressure Switches on Cooling Only Units	S
High Pressure Switch and Loss Of Charge Switch On HP	S
Indoor Coil Freeze Protection	S
Factory Supplied Filter Dryer For Field Installation	S
Accumulator On Heat Pumps Units	S
Ease Of Service And Maintenance	
Control Box Accessible From Bottom Of Unit	S
Cleanable Filters	S
Liquid Line Pressure Tabs	S
Suction And Discharge Pressure Tabs	S
Application Flexibility	
208/230 and 460 3 Phase on size 036, 048, and 060	S
Electric Heat On 40QAA Units	S
Long lines up to 200 Ft (accessories required)	A
Outside Air Intake Kit	A
Power Ventilation Kit	A
Low Ambient Controls (-20° F)	A
Knock Out For Outside Air Intake	S
Wind Baffles	A
Wall Mounted Thermostats	A
Warranty	
5-Year Compressor Warranty	S
1-Year Parts Warranty	S
Compressor Extended Warranty Years 6 Thru 10	O
All Parts And Labor Years 2 Thru 5	O
All Parts And Labor Years 2 Thru 5, Compressor Years 6 Thru 10	O

Legend
 S Standard
 A Accessory
 O Optional

40QAC/38HDR -- 40QAA/38QRF

OUTDOOR UNITS

LOW AMBIENT KIT

The kit controls condenser fan cycling using a pressure switch. It is specifically designed to control fan-motor cycles in response to saturated condensing pressure. This device maintains a constant saturated condensing temperature of 100 °F ± 10 °F (37.78°C ± -12.22 °C) at outdoor-air temperatures between 55 °F and -20 °F (12.78°C ± -12.22°C), and can be used on all outdoor units without changing the outdoor fan motor.

WINTER START CONTROL

The Winter Start Control is a SPST delay relay. The control bypasses the low pressure switch for approximately 3 minutes to permit start-up for cooling operation under low load conditions at low ambient temperatures. This relay is recommended on all systems that have the accessory Low Ambient Kit. Winter Start Control can also be used to provide low ambient cooling at outdoor ambient temperatures between 55°F and 40°F (12.8°C and 4.4°C).

ISOLATION RELAY

To be used when Low Ambient Kit is used with heat pumps. This will ensure that the pressure switch is bypassed if unit is running in heat pump mode.

LIQUID LINE SOLENOID VALVE

The Liquid Line Solenoid Valve is an electronically operated shutoff valve that is installed at the outdoor unit to stop and start refrigerant flow in response to compressor operation. The valve maintains a column of refrigerant in the liquid line between compressor operating cycles and is required for certain long-line applications and to improve system performance.

CRANKCASE HEATER

The Crankcase Heater is available for units with scroll compressors and clamps onto the compressor oil sump. It is recommended for low ambient and long line applications.

WIND BAFFLES

The Wind Baffle is an accessory sheet metal wrapper used to provide improved unit operation during high winds and is recommended whenever the Low Ambient Kit is used.

STANDARD FEATURES AND ACCESSORIES CONTINUED

INDOOR UNITS

CONDENSATE PUMP

(part # 53DS-900---081)

For those applications where the ceiling-suspended unit is not installed close to an outside wall, and an adequate pitch cannot be provided, the pump mounts inside the unit with quick plug-in connections and provide a maximum lift capability of 20 inches (508 mm).

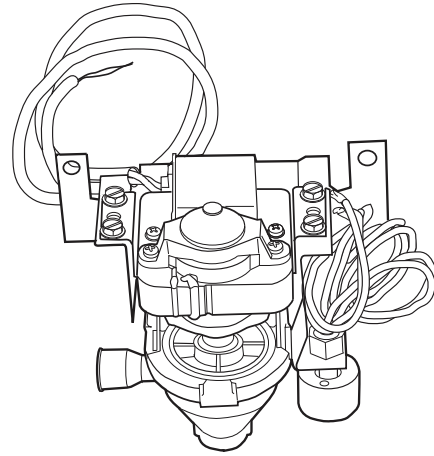

A08572

Fig. 1 – Condensate Pump

FRESH AIR INTAKE KIT

(Part # 53DS-900---006)

When the ceiling-suspended unit is installed against an outside wall, the Fresh Air Intake Kit provides variable (up to 30%) fresh air capability. The kit has a filter that mounts at the fan coil unit and provides filtering of the outside air before it enters the unit.

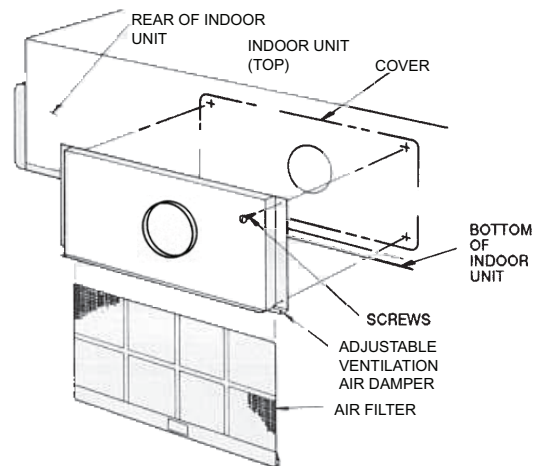

A08573

Fig. 2 – Fresh Air Intake Kit

POWER VENTILATION KIT

(Part # 53DS-900---066)

The Power Ventilation Kit is used in conjunction with the Fresh Air Intake Kit and is used when the unit is not installed against an outside wall and where static pressure needs to be overcome.

40QAC/38HDR -- 40QAC/38QRR

WIRED CONTROLLER

HW Thermostat (Part # 53DFS250-HW)

A specially designed thermostat for ceiling-suspended systems that incorporate 3-speed fan control. These can be used on both cooling-only and heat pump systems.

- Large, Clear Display with Backlighting—current temperature, set temperature and time are easy-to-read and all are displayed on the main screen.
- Menu Driven Programming - Provides guidance through the scheduling process, showing only necessary information and choices on each screen.
- Ability to Select Multiple Days - allows easy customizing for unique schedules.
- Real-Time Clock - keeps time during power failure; automatically updates for daylight saving time.
- Precise Temperature Control ($\pm 1^{\circ}\text{F}$) - reliable, consistent comfort.
- Multiple OVERRIDE options - can modify schedule for a specific period of time (up to 365 days).
- Speedy same-schedule programming - no need to copy multiple days.
- Programmable or non-programmable modes.
- Remote setback input for occupancy sensors or timeclocks.
- VersaSpeed™ fan ramping algorithm and fan reset algorithm

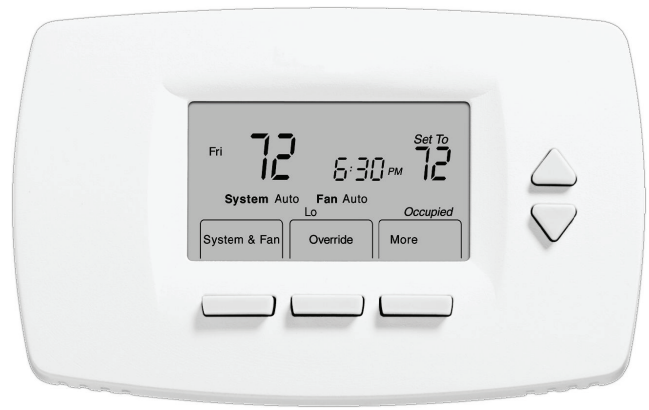

Fig. 3 – 53DFS250-HW Thermostat

AHRI* CAPACITY RATINGS

System Type	Outdoor Section	Indoor Section	Standard CFM		Net Cooling BTUH	SEER	EER	High Heat	
			Outdoor	Indoor				BTUH	HSPF
Cooling	38HDR018---3	40QAC024---3	1720	480	18,000	13	11.5	N/A	N/A
	38HDR024---3	40QAC024---3	1720	550	23,000	13	11.5	N/A	N/A
	38HDR030---3	40QAC036---3	3900	840	29,000	13	12.0	N/A	N/A
	38HDR036---3	40QAC036---3	3900	840	33,000	13	11.4	N/A	N/A
	38HDR036---5	40QAC036---3	3900	840	33,000	13	11.4	N/A	N/A
	38HDR036---6	40QAC036---3	3900	840	33,000	13	11.4	N/A	N/A
	38HDR048---3	40QAC048---3	3900	1130	46,000	13	11.5	N/A	N/A
	38HDR048---5	40QAC048---3	3900	1130	46,000	13	11.5	N/A	N/A
	38HDR048---6	40QAC048---3	3900	1130	46,000	13	11.5	N/A	N/A
	38HDR060---3	40QAC060---3	3900	1600	57,000	13	11.4	N/A	N/A
	38HDR060---5	40QAC060---3	3900	1600	57,000	13	11.4	N/A	N/A
	38HDR060---6	40QAC060---3	3900	1600	57,000	13	11.4	N/A	N/A
Heat Pumps	38QRR018---3	40QAQ024---3	1720	480	17,000	13	11.7	17,000	7.7
	38QRR024---3	40QAQ024---3	1720	550	23,000	13	11.4	23,800	7.7
	38QRR030---3	40QAQ036---3	3900	840	28,000	13	11.2	28,800	7.7
	38QRR036---3	40QAQ036---3	3900	840	33,000	13	11.6	32,000	7.7
	38QRR036---5	40QAQ036---3	3900	840	33,000	13	11.6	32,000	7.7
	38QRR036---6	40QAQ036---3	3900	840	33,000	13	11.6	32,000	7.7
	38QRR048---3	40QAQ048---3	3900	1130	45000	13	11.5	45000	7.7
	38QRR048---5	40QAQ048---3	3900	1130	45000	13	11.5	45000	7.7
	38QRR048---6	40QAQ048---3	3900	1130	45000	13	11.5	45000	7.7
	38QRR060---3	40QAQ060---3	3900	1600	56000	13	11.4	56000	7.7
	38QRR060---5	40QAQ060---3	3900	1600	56000	13	11.4	56000	7.7
	38QRR060---6	40QAQ060---3	3900	1600	56000	13	11.4	56000	7.7

40QAC/38HDR -- 40QAQ/38QRR

*Air Conditioning, Heating & Refrigeration Institute

Legend

HSPF – Heating Seasonal Performance Factor

EER – Energy Efficiency Rating

SEER – Seasonal Energy Efficiency Ratio

NOTES:

1. Ratings are net values reflecting the effects of circulating fan heat. Ratings are based on: Cooling Standard: 80°F (26.67°C) db, 67°F (19.44°C) wb air entering indoor unit and 95°F (35°C) db air entering outdoor unit. High Temperature Heating Standard: 70°F (21.11°C) db air entering indoor unit and 47°F (8.33°C) db, 43°F (6.11°C) wb air entering outdoor unit.
2. Ratings are based on 25 ft. (7.62 m) of interconnecting refrigerant lines.
3. All system ratings are based on fan coil units operating at high fan speed. Consult Physical Data tables for airflows at all available fan speeds.

CLEARANCES - OUTDOOR UNIT

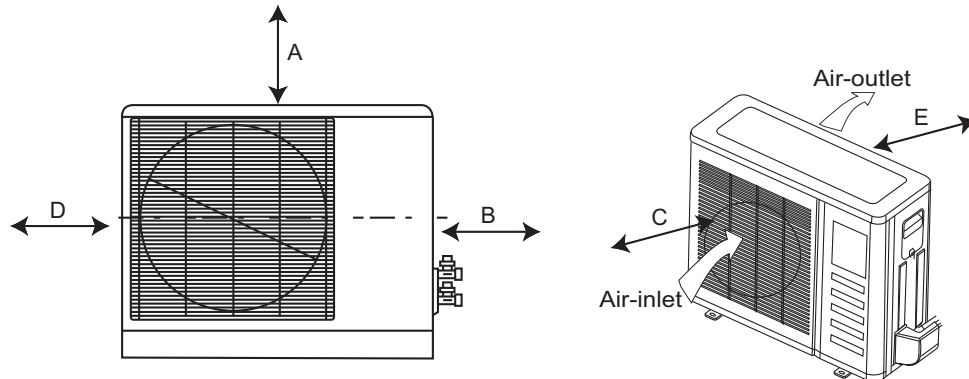

A08436

UNIT	Coil Facing Wall – in. (mm)	Fan Facing Wall – in. (mm)
A	24 (610)	24 (610)
B	36 (914)	36 (914)
C	36 (914)	8 (203)
D	6 (152)	8 (203)
E	6 (152)	8 (203)

Fig. 4 – Outdoor Unit Clearance

OUTDOOR UNIT DIMENSIONS

UNIT	SERIES	ELECTRICAL CHARACTERISTICS	A	B	C	D	E	F	G	H	J	K	L	M	N	P	OPERATING WEIGHT(lbs)	SHIPPING WEIGHT(lbs)	SHIPPING DIMENSIONS (L x W x H)
38HDR018	1	X	0	25 1/8"	36 15/16"	14 9/16"	16"	23 7/16"	17 3/16"	17 1/8"	13"	6 5/8"	11 1/4"	5/8"	2 15/16"	6"	155	171	42 9/10" X 18" X 28 1/10"
38HDR024	1,2	X	0	31 1/8"	36 15/16"	14 9/16"	16"	23 7/16"	17 3/16"	23 1/8"	14"	6 3/4"	11 5/8"	5/8"	2 15/16"	6"	180	198	42 9/10" X 18" X 34 1/10"
38HDR030	1	X	0	37 3/16"	44 9/16"	17 1/16"	18 7/16"	30 1/2"	29 3/16"	34 1/16"	13 11/16"	8 1/8"	15 7/8"	3/4"	3 7/16"	6 1/2"	200	223	50 1/2" X 20 1/2" X 40 2/10"
38HDR036	1	X	0	37 3/16"	44 9/16"	17 1/16"	18 7/16"	30 1/2"	29 3/16"	34 1/16"	13 11/16"	8 1/8"	15 7/8"	3/4"	3 7/16"	6 1/2"	218	240	50 1/2" X 20 1/2" X 40 2/10"
38HDR048	1,2	X	0	43 3/16"	44 9/16"	17 1/16"	18 7/16"	30 1/2"	29 3/16"	40 1/16"	14 1/2"	8 1/2"	18 7/8"	7/8"	3 7/16"	6 1/2"	284	309	50 1/2" X 20 1/2" X 46 2/10"
38HDR060	1,2	X	0	43 3/16"	44 9/16"	17 1/16"	18 7/16"	30 1/2"	29 3/16"	40 1/16"	14 1/2"	8 1/2"	18 7/8"	7/8"	3 7/16"	6 1/2"	294	319	50 1/2" X 20 1/2" X 46 2/10"

X = YES
O = NO

208-230-160	460-3-60
230-160	208/230-3-60

- REQUIRED CLEARANCES: WITH COIL FACING WALL; ALLOW 6" MIN CLEARANCE ON COIL SIDE AND 36" MIN CLEARANCE ON COMPRESSOR END AND FAN SIDE. WITH FAN FACING WALL; ALLOW 8" MIN CLEARANCE ON FAN SIDE AND COIL END AND 36" MIN CLEARANCE ON COMPRESSOR END AND COIL SIDE. WITH MULTI UNIT APPLICATION; ARRANGE UNITS SO DISCHARGE OF ONE DOES NOT ENTER INLET OF ANOTHER.
- MINIMUM OUTDOOR OPERATING AMBIENT IN COOLING MODE IS 55°F. MAX. 125°F.
- SERIES DESIGNATION IS THE 13TH POSITION OF THE UNIT MODEL NUMBER.
- CENTER OF GRAVITY
- ALL DIMENSIONS ARE IN "INCHES" UNLESS NOTED.

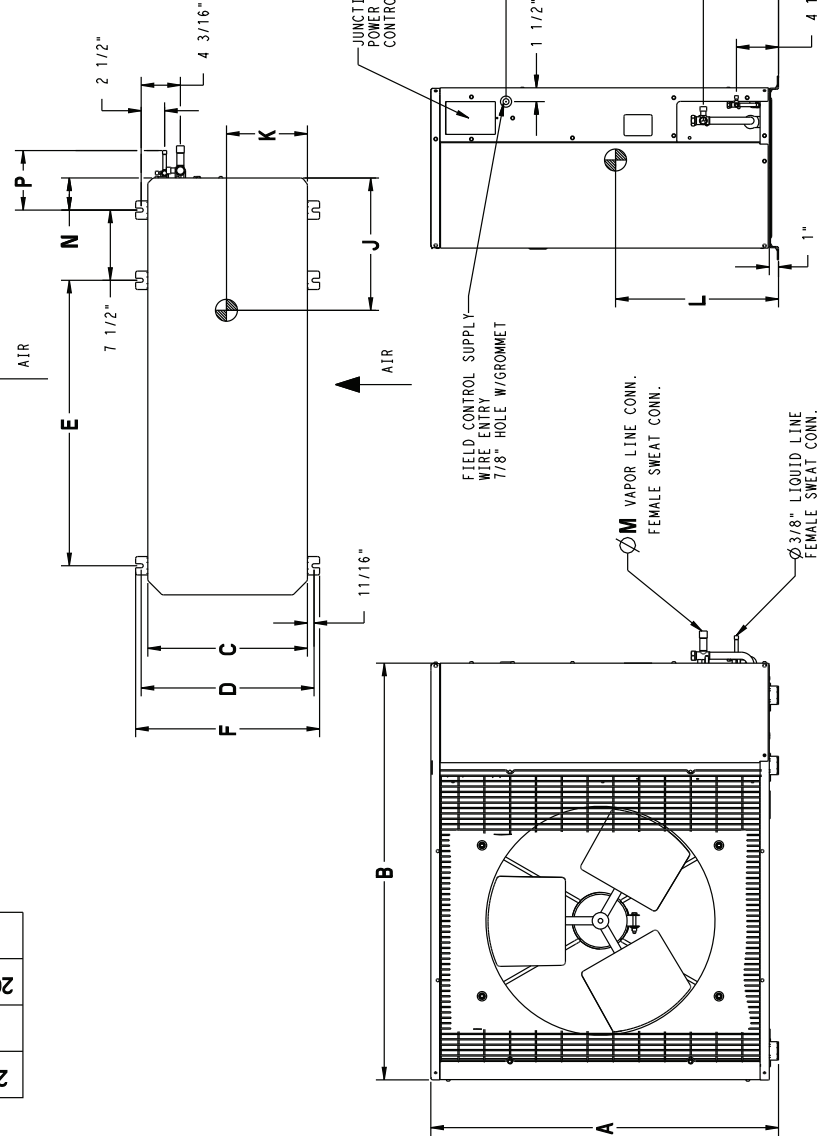

UNIT SIZE	MINIMUM MOUNTING PAD DIMENSIONS
18, 24	23" X 42"
30, 36, 48, 60	24" X 50"

Fig. 5 – 38HDR Dimensions - English

OUTDOOR UNIT DIMENSIONS CONTINUED

UNIT	SERIES	ELECTRICAL CHARACTERISTICS	A	B	C	D	E	F	G	H	J	K	L	M	N	P	OPERATING WEIGHT(KG)	SHIPPING WEIGHT(KG)	SHIPPING DIMENSIONS (L x W x H)
38HDR018	1	X 0 0	638.2	938.2	369.9	406.4	595.3	436.6	435.0	558.8	330.2	168.3	285.8	15.9	74.6	152.4	70.4	77.7	1090.2 X 457.7 X 714.3
38HDR024	1,2	X 0 0	790.6	938.2	369.9	406.4	595.3	436.6	587.4	711.2	355.6	171.5	295.3	15.9	74.6	152.4	81.8	90.0	1090.2 X 457.7 X 866.7
38HDR030	1	X 0 0	944.6	1131.9	433.4	468.3	774.7	498.5	741.4	865.2	347.7	206.4	403.2	19.0	87.3	165.1	90.9	101.4	1282.7 X 520.7 X 1020.7
38HDR036	1	X 0 X	944.6	1131.9	433.4	468.3	774.7	498.5	741.4	865.2	347.7	206.4	403.2	19.0	87.3	165.1	99.0	109.0	1282.7 X 520.7 X 1020.7
38HDR048	1,2	X 0 X	1097.0	1131.9	433.4	468.3	774.7	498.5	893.8	1017.6	368.3	215.9	479.4	22.2	87.3	165.1	129.0	140.4	1282.7 X 520.7 X 1173.1
38HDR060	1,2	X 0 X	1097.0	1131.9	433.4	468.3	774.7	498.5	893.8	1017.6	368.3	215.9	479.4	22.2	87.3	165.1	133.6	145.0	1282.7 X 520.7 X 1173.1

X = YES
O = NO

- REQUIRED CLEARANCES: WITH COIL FACING WALL; ALLOW 152.4 MIN CLEARANCE ON COIL SIDE AND COIL END AND 914.4 MIN CLEARANCE ON COMPRESSOR END AND FAN SIDE. WITH FAN FACING WALL; ALLOW 203.2 MIN CLEARANCE ON FAN SIDE AND COIL END AND 914.4 MIN CLEARANCE ON COMPRESSOR END AND COIL SIDE. WITH MULTI UNIT APPLICATION; ARRANGE UNITS SO DISCHARGE OF ONE DOES NOT ENTER INLET OF ANOTHER.
- MINIMUM OUTDOOR OPERATING AMBIENT IN COOLING MODE IS 12.8°C. MAX. 51.7°C.
- SERIES DESIGNATION IS THE 13TH POSITION OF THE UNIT MODEL NUMBER.
- CENTER OF GRAVITY
- ALL DIMENSIONS ARE IN "MM" UNLESS NOTED.

FIELD POWER SUPPLY CONN. HOLE SIZES PROVIDED:
22.22 - 12.70 TRADE
30.16 - 19.05 TRADE
34.92 - 25.40 TRADE

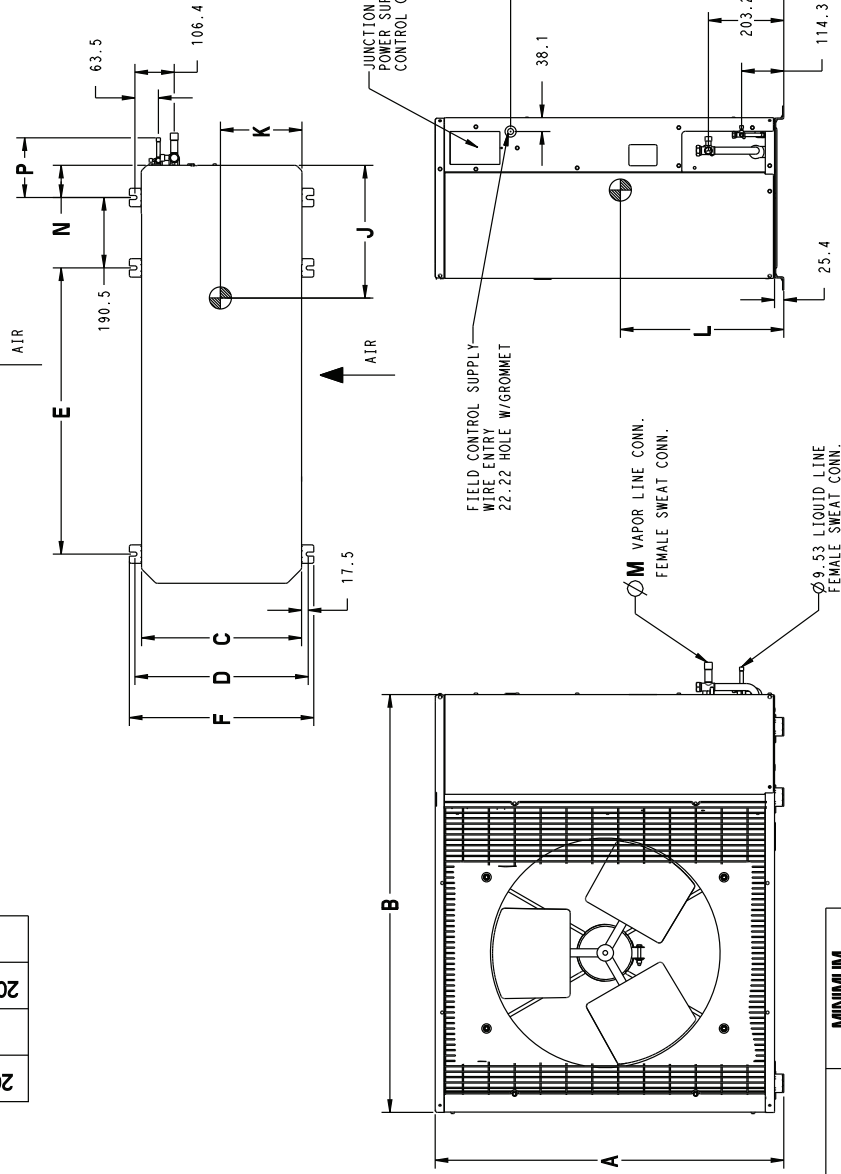

UNIT SIZE	MINIMUM MOUNTING PAD DIMENSIONS
18.24	584.2 X 1066.8
30.36, 48.60	609.6 X 1270.0

Fig. 6 - 38HDR Dimensions - SI

40QAC/38HDR -- 40QAC/38QRR

OUTDOOR UNIT DIMENSIONS

UNIT	SERIES	ELECTRICAL CHARACTERISTICS	A	B	C	D	E	F	G	H	J	K	L	M	N	P	OPERATING WEIGHT(lbs)	SHIPPING WEIGHT(lbs)	SHIPPING DIMENSIONS (L x W x H)				
38QRR018	0	X	0	0	0	25 1/8"	36 15/16"	14 9/16"	16"	23 7/16"	17 3/16"	17 1/8"	17 1/8"	22"	13"	6 5/8"	11 1/4"	5/8"	2 15/16"	6"	167	183	42 9/10" X 18" X 28 1/10"
38QRR024	0	X	0	0	0	31 1/8"	36 15/16"	14 9/16"	16"	23 7/16"	17 3/16"	23 1/8"	23 1/8"	28"	14"	6 3/4"	11 5/8"	5/8"	2 15/16"	6"	176	194	42 9/10" X 18" X 34 1/10"
38QRR030	0	X	0	0	0	37 3/16"	44 9/16"	17 1/16"	18 7/16"	30 1/2"	19 5/8"	29 3/16"	34 1/16"	34 1/16"	13 11/16"	3 7/16"	15 7/8"	3/4"	3 7/16"	6 1/2"	187	210	50 1/2" X 20 1/2" X 40 2/10"
38QRR036	0	X	0	0	0	37 3/16"	44 9/16"	17 1/16"	18 7/16"	30 1/2"	19 5/8"	29 3/16"	34 1/16"	34 1/16"	13 11/16"	3 7/16"	15 7/8"	3/4"	3 7/16"	6 1/2"	232	255	50 1/2" X 20 1/2" X 40 2/10"
38QRR048	0	X	0	0	0	43 3/16"	44 9/16"	17 1/16"	18 7/16"	30 1/2"	19 5/8"	35 3/16"	40 1/16"	40 1/16"	14 1/2"	8 1/2"	18 7/8"	7/8"	3 7/16"	6 1/2"	278	303	50 1/2" X 20 1/2" X 46 2/10"
38QRR060	0	X	0	0	0	43 3/16"	44 9/16"	17 1/16"	18 7/16"	30 1/2"	19 5/8"	35 3/16"	40 1/16"	40 1/16"	14 1/2"	8 1/2"	18 7/8"	7/8"	3 7/16"	6 1/2"	306	331	50 1/2" X 20 1/2" X 46 2/10"

- 1. REQUIRED CLEARANCES: WITH COIL FACING WALL; ALLOW 6" MIN CLEARANCE ON COIL SIDE AND COIL END AND 36" MIN CLEARANCE ON COMPRESSOR END AND FAN SIDE. WITH FAN FACING WALL; ALLOW 8" MIN CLEARANCE ON FAN SIDE AND COIL END AND 36" MIN CLEARANCE ON COMPRESSOR END AND COIL SIDE. WITH MULTI UNIT APPLICATION; ARRANGE UNITS SO DISCHARGE OF ONE DOES NOT ENTER INLET OF ANOTHER.
- 2. MINIMUM OUTDOOR OPERATING AMBIENT IN COOLING MODE IS 55°F, MAX. 125°F.
- 3. SERIES DESIGNATION IS THE 13TH POSITION OF THE UNIT MODEL NUMBER.
- 4. CENTER OF GRAVITY
- 5. ALL DIMENSIONS ARE IN "INCHES" UNLESS NOTED.

X = YES
0 = NO

460-3-60
208/230-3-60
230-1-60
208-230-1-60

UNIT SIZE	MINIMUM MOUNTING PAD DIMENSIONS
18.24	23" X 42"
30, 36, 48, 60	24" X 50"

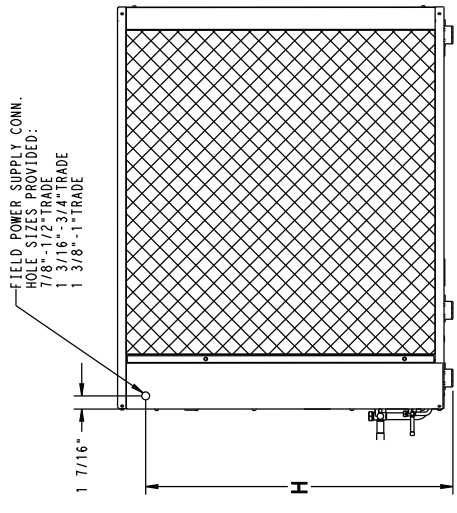
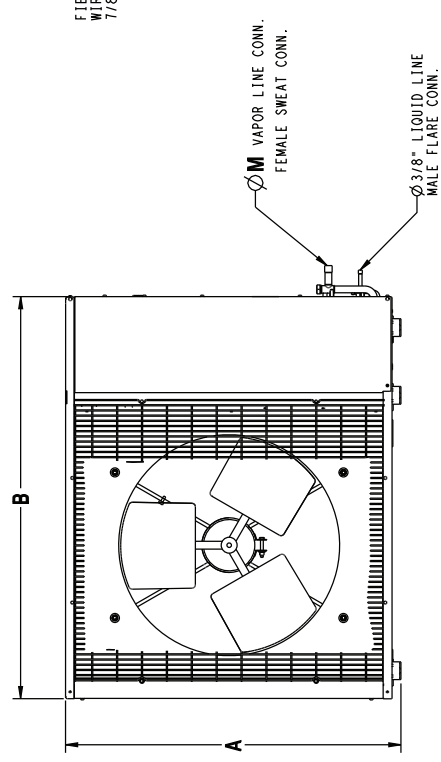
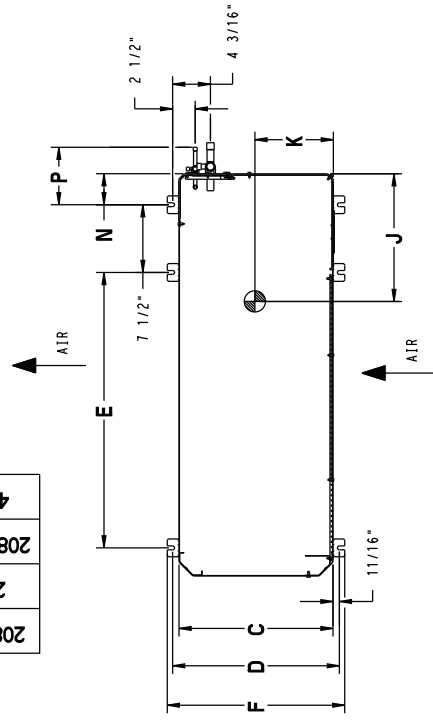



Fig. 7 - 38QRR Dimensions - English

OUTDOOR UNIT DIMENSIONS CONTINUED

UNIT	SERIES	ELECTRICAL CHARACTERISTICS	A	B	C	D	E	F	G	H	J	K	L	M	N	P	OPERATING WEIGHT(KG)	SHIPPING WEIGHT(KG)	SHIPPING DIMENSIONS (L x W x H)
380RR018	0	X 0 0	638.2	938.2	369.9	406.4	595.3	436.6	435.0	558.8	330.2	168.3	285.8	15.9	74.6	132.4	75.9	83.2	1090.2 X 457.7 X 714.3
380RR024	0	X 0 0	790.6	938.2	369.9	406.4	595.3	436.6	587.4	711.2	355.6	171.5	295.3	15.9	74.6	132.4	80.0	88.2	1090.2 X 457.7 X 866.7
380RR030	0	X 0 0	944.6	1131.9	433.4	468.3	774.7	498.5	741.4	865.2	347.7	206.4	403.2	19.0	87.3	185.1	85.0	95.4	1282.7 X 520.7 X 1020.7
380RR036	0	X 0 X	944.6	1131.9	433.4	468.3	774.7	498.5	741.4	865.2	347.7	206.4	403.2	19.0	87.3	185.1	105.4	115.9	1282.7 X 520.7 X 1020.7
380RR048	0	X 0 X	1097.0	1131.9	433.4	468.3	774.7	498.5	893.8	1017.6	368.3	215.9	479.4	22.2	87.3	185.1	126.4	137.7	1282.7 X 520.7 X 1173.1
380RR060	0	X 0 X	1097.0	1131.9	433.4	468.3	774.7	498.5	893.8	1017.6	368.3	215.9	479.4	22.2	87.3	185.1	139.0	150.4	1282.7 X 520.7 X 1173.1

X = YES
O = NO

- REQUIRED CLEARANCES: WITH COIL FACING WALL: ALLOW 152.4 MIN CLEARANCE ON COIL SIDE AND COIL END AND 914.4 MIN CLEARANCE ON COMPRESSOR END AND FAN SIDE. WITH FAN FACING WALL ALLOW 203.2 MIN CLEARANCE ON FAN SIDE AND COIL END AND 914.4 MIN CLEARANCE ON COMPRESSOR END AND COIL SIDE. WITH MULTI UNIT APPLICATION: ARRANGE UNITS SO DISCHARGE OF ONE DOES NOT ENTER INLET OF ANOTHER.
- MINIMUM OUTDOOR OPERATING AMBIENT IN COOLING MODE IS 12.8°C, MAX. 51.7°C.
- SERIES DESIGNATION IS THE 13TH POSITION OF THE UNIT MODEL NUMBER.
- CENTER OF GRAVITY 
- ALL DIMENSIONS ARE IN "MM" UNLESS NOTED.

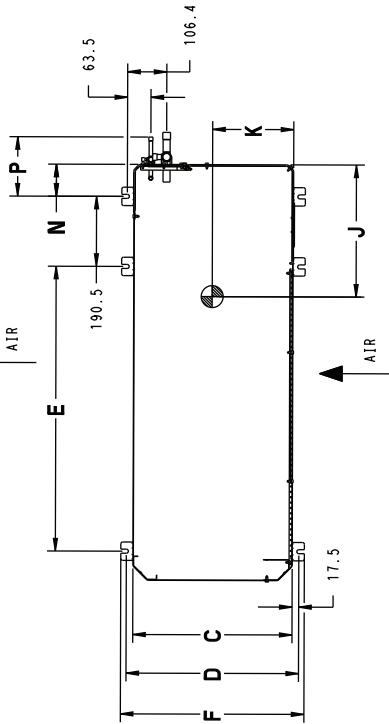

UNIT SIZE	MINIMUM MOUNTING PAD DIMENSIONS
18.24	584.2 X 1066.8
30.36, 48.60	609.6 X 1270.0

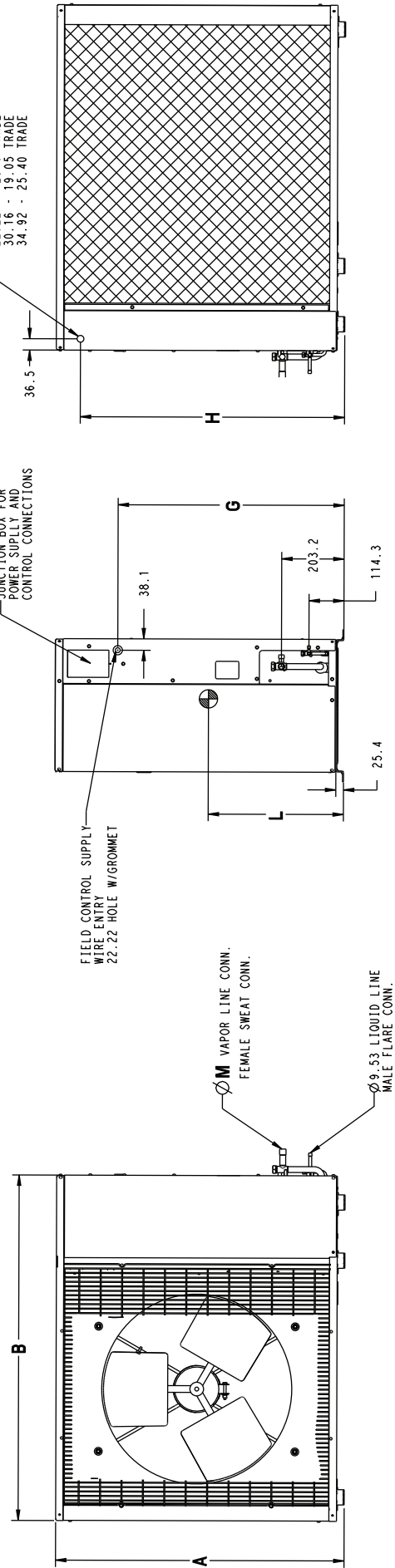
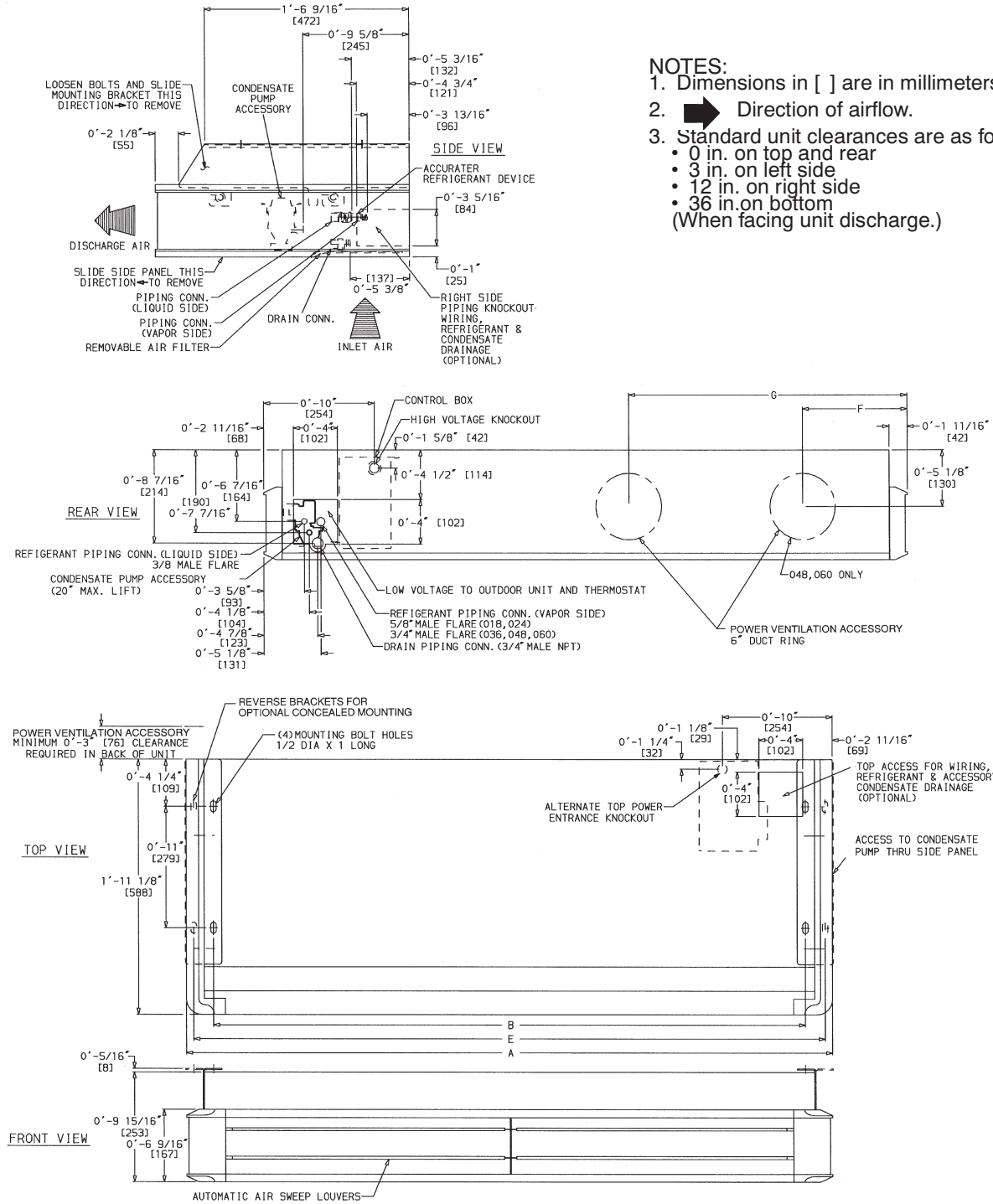

Fig. 8 - 38QRR Dimensions - SI

40QAC/38HDR -- 40QAC/38QRR

DIMENSIONS - INDOOR UNIT

40QAC/38HDR -- 40QAO/38QRR



A08580

UNIT SIZE	WEIGHT (lb)		A		B		E		F		G	
	Cooling Only	Heat Pump	ft-in.	mm	ft-in.	mm	ft-in.	mm	ft-in.	mm	ft-in.	mm
024	108	110	4-215/16	1294	3-10	1169	4-15/8	1260	—	—	1-95/8	549
036	117	119	4-1013/16	1493	4-57/8	1368	4-91/2	1459	—	—	2-11/2	648
048	149	151	5-119/16	1817	5-65/8	1692	5-101/4	1783	1-97/8	555	3-31/16	992
060	179	181	7-8	2336	7-3	2211	7-65/8	2302	1-115/8	601	4-119/16	1512

Fig. 9 – 40QA Dimensions

PHYSICAL DATA - OUTDOOR UNIT 38HDR

Outdoor Unit 38HDR	018	024	030	036	48	60
System Voltage	208/230-1-60	208/230-1-60	208/230-1-60	208/230-1-60 208/230-3-60 460-3-60	208/230-1-60 208/230-3-60 460-3-60	208/230-1-60 208/230-3-60 460-3-60
Nominal Capacity (Btuh)	18000	24000	30000	36000	48000	60000
Operating Weight lb(kg)	166 (75.3)	176 (79.8)	250 (113.4)	250 (113.4)	278 (126.4)	306 (139)
Refrigerant Type	R-410A					
Metering Device	TXV					
Unit Factory Charge	6.3 (2.9)	6.5 (3.0)	8.7 (4.0)	8.7 (4.0)	12 (5.5)	12 (5.5)
System Charge (25 ft line) lb (kg)	7.0 (3.2)	7.8 (3.5)	10.1 (4.6)	8.9 (4.0)	12.2 (5.5)	12.5 (5.7)
Additional Charge	.7 (.32)	1.3 (.57)	1.4 (.64)	.2 (.1)	.2 (.1)	.5 (.23)
Compressor						
Type	Scroll					
Oil Charge (POE -oz)	25	25	25	25	42	42
Crankcase Heater	-	-	40	40	40	40
Accumulator	Yes					
Outdoor Fan						
Rpm/CFM	840/1720	840/1720	840/3900	840/3900	840/3900	840/3900
Diameter (in) .. No. of Blades	18...3	18...3	24...3	24...3	24...3	24...3
Motor HP	1/8	1/8	1/4	1/4	1/4	1/4
Outdoor Coil						
Face Area (sq. ft)	5.8	7.3	12.1	12.1	14.1	14.1
No. Rows	2	3	2	2	3	3
Fins per inch	20	20	20	20	20	20
Circuits	2	3	3	6	6	6
High Pressure Switch						
Cut-In (psig)	420±25	420±25	420±25	420±25	420±25	420±25
Cut-Out (psig)	650±10	650±10	650±10	650±10	650±10	650±10
Low Pressure Switch						
Cut-In (psig)	45±25	45±25	45±25	45±25	45±25	45±25
Cut-Out (psig)	20±5	20±5	20±5	20±5	20±5	20±5
Fusible Plug ° F (° C)	210 (99)					
Refrigerant Lines						
Connection Type	Liquid/Suction – Sweat					
Suction/Vapor (in) OD	5/8		3/4		7/8	7/8†
Liquid Line (in) OD	3/8					
Maximum Length* ft (m)	200 (61)					
Max Lift (Fan Coil Above) ft (m)	65 (20)					
Max Drop (Fan Coil Below) ft (m)	200 (61)					
Controls						
Control Voltage	24 vac					
External Finish	Gray					

* Refer to Long Line Application

† Valve size connection is 7/8 inch. Recommended line size is 1-1/8 inch.

40QAC/38HDR -- 40QAC/38QRH

PHYSICAL DATA (CONT.) - OUTDOOR UNIT 38QRR

Outdoor Unit 38QRR	018	024	030	036	048	060
System Voltage	208/230-1-60	208/230-1-60	208/230-1-60	208/230-1-60 208/230-3-60 460-3-60	208/230-1-60 208/230-3-60 460-3-60	208/230-1-60 208/230-3-60 460-3-60
Refrigerant Type	R-410A					
Unit Factory Charge	6.8 (3.1)	7.0 (3.2)	12.0 (5.4)	12.5 (5.7)	12.2 (5.5)	12.8 (5.8)
System Charge (25 ft line)	7.5 (3.4)	7.8 (3.5)	12.0 (5.4)	13.0 (5.9)	12.2 (5.5)	12.8 (5.8)
Additional Charge	.7 (.32)	.8 (.36)	0.0	.5 (.23)	0.0	0.0
Heating Metering Device	Accurator at Outdoor Unit					
Cooling Metering Device	Accurator at Indoor Unit					TXV
Cooling Piston	49	55	65	70	80	-
Heating Piston	40	43	55	63	73	80
Compressor						
Type	Scroll					
Oil Charge (POE -oz)	25	25	25	25	42	42
Crankcase Heater	-	-	40	40	40	40
Outdoor Fan						
Rpm/CFM	840/1720	840/1720	850/3900	850/3900	850/3900	850/3900
Diameter (in) .. No. of Blades	18...3	18...3	24...3	24...3	24...3	24...3
Motor HP	1/8	1/8	1/4	1/4	1/4	1/4
Outdoor Coil						
Face Area (sq. ft)	5.8	7.3	12.1	12.1	14.1	14.1
No. Rows	3	3	2	3	3	3
Fins per inch	20	20	20	20	20	20
Circuits	3	3	6	6	6	6
High Pressure Switch						
Cut-In (psig)	420±25	420±25	420±25	420±25	420±25	420±25
Cut-Out (psig)	650±10	650±10	650±10	650±10	650±10	650±10
Low Pressure Switch						
Cut-In (psig)	45±25	45±25	45±25	45±25	45±25	45±25
Cut-Out (psig)	20±5	20±5	20±5	20±5	20±5	20±5
Fusible Plug ° F (° C)	210 (99)					
Refrigerant Lines						
Connection Type	Liquid Line – Flare/Suction – Sweat					
Suction/Vapor (in) OD	5/8		3/4			
Liquid Line (in) OD	3/8					
Maximum Length* ft (m)	200 (61)					
Max Lift (Fan Coil Above) ft (m)	65 (20)					
Max Drop (Fan Coil Below) ft (m)	200 (61)					
Controls						
Control Voltage	24 vac					
External Finish	Gray					

* Refer to Long Line Application

40QAC/38HDR -- 40QAO/38QRR

PHYSICAL DATA (CONT.) - INDOOR UNITS 40QAC / 40QAQ

Indoor Unit 40QAC	24	36	48	60
System Voltage	208/230-1-60	208/230-1-60	208/230-1-60	208/230-1-60
Control Voltage	24vac			
Operating Weight lb(kg)	108 (49.1)	117 (53.2)	149 (67.7)	179 (81.4)
Refrigerant Type	R-410A			
Metering Device	TXV			
Moisture Removal Rate (Pints/hr)	7.1	9.5	13.4	15.1
Indoor Fan				
RPM/CFM (High)	1050/500*	1275/840	1435/1200	1275/1600
RPM/CFM (Medium)	690/400	972/740	1388/1160	972/1220
RPM/CFM (Low)	552/320	830/640	470/670	830/1080
Motor HP	1/15		1/6	
Blower Quantity...Size (in)	2...6x8		3...6x8	4...6x8
Indoor Coil				
Face Area (sq. ft)	2.2	2.6	3.3	4.5
No. Rows	4	4	4	4
Fins per inch	15	15	15	15
Circuits	4	4	8	8
Filters				
Quantity...Size (in)	4...12 x 8.75	5...10.6 x 8.75	4...10.6 x 8.75 2...12 x 8.75	6...12 x 8.75
Refrigerant Lines				
Connection Type	Flare			
Liquid Line (in) OD	3/8			
Vapor Line (in) OD	5/8	3/4		
Condensate Drain				
MTP Outside Diameter (in) **	3/4			
External Finish	White With Black Trim End Pieces			

* When matched with 38HDR018 RPM/CFM will be 862/500 (high), 690/400 (medium), and 552/320 (low)

** 5/8" flexible tubing is required when using condensate pump accessory.

Indoor Unit 40QAQ	24	36	48	60
System Voltage	208/230-1-60	208/230-1-60	208/230-1-60	208/230-1-60
Control Voltage	24vac			
Operating Weight lb(kg)	110 (50)	119 (54.1)	151 (68.6)	181 (82.3)
Refrigerant Type	R-410A			
Metering Device	Accurator			TXV
Moisture Removal Rate (Pints/hr)	7.1	9.5	13.4	15.1
Indoor Fan				
RPM/CFM (High)	1050/500*	1275/840	1435/1200	1275/1600
RPM/CFM (Medium)	690/400	972/740	1388/1160	972/1220
RPM/CFM (Low)	552/320	830/640	470/670	830/1080
Motor HP	1/15		1/6	
Blower Quantity...Size (in)	2...6x8		3...6x8	4...6x8
Indoor Coil				
Face Area (sq. ft)	2.2	2.6	3.3	4.5
No. Rows	4	4	4	4
Fins per inch	15	15	15	15
Circuits	4	4	8	8
Filters				
Quantity...Size (in)	4...12 x 8.75	5...10.6 x 8.75	4...10.6 x 8.75 2...12 x 8.75	6...12 x 8.75
Refrigerant Lines				
Connection Type	Flare			
Liquid Line (in) OD	3/8			
Vapor Line (in) OD	5/8	3/4	7/8***	
Condensate Drain				
MTP Outside Diameter (in) **	3/4			
External Finish	White With Black Trim End Pieces			

* When matched with 38HDR018 RPM/CFM will be 862/500 (high), 690/400 (medium), and 552/320 (low)

** 5/8" flexible tubing is required when using condensate pump accessory.

*** Connection size is 3/4". Recommended line size is 7/8"

40QAC/38HDR -- 40QAQ/38QRF

PERFORMANCE DATA

COOLING CAPACITIES 38HDR018 / 40QAC024*

Temp °F (°C) Air Entering Condenser (Edb)		Air Entering Evaporator – Cfm/BF											
		320/0.02				400/0.03				500/0.03			
		Air Entering Evaporator – Ewb °F (°C)											
		57 (13.9)	62 (16.7)	67 (19.4)	72 (22.2)	57 (13.9)	62 (16.7)	67 (19.4)	72 (22.2)	57 (13.9)	62 (16.7)	67 (19.4)	72 (22.2)
55 (12.8)	TCG	17.2	18.7	20.1	21.5	17.7	19.1	20.5	21.8	18.1	19.5	20.8	22.1
	SHG	16.8	15.0	12.9	10.7	17.2	15.7	13.3	10.9	18.1	16.4	13.8	11.2
	TC	17.0	18.5	19.9	21.3	17.4	18.8	20.2	21.6	17.8	19.3	20.6	21.9
	kW	0.94	0.94	0.94	0.94	0.94	0.94	0.94	0.94	0.94	0.95	0.94	0.94
	CMP	0.75	0.75	0.75	0.75	0.75	0.75	0.75	0.75	0.75	0.76	0.75	0.76
	LDB	46.3	50.2	54.9	59.7	49.0	52.1	56.8	61.4	51.3	54.2	58.7	63.1
65 (18.3)	LWB	41.6	46.9	52.5	58.2	43.0	48.4	54.0	59.7	44.5	49.9	55.4	61.1
	TCG	16.3	18.2	19.6	21.1	17.0	18.6	20.0	21.4	17.7	18.9	20.3	21.6
	SHG	16.3	14.9	12.8	10.6	17.0	15.5	13.2	10.8	17.7	16.4	13.7	11.1
	TC	16.1	17.9	19.4	20.8	16.8	18.3	19.7	21.1	17.4	18.7	20.1	21.4
	kW	1.06	1.05	1.06	1.06	1.06	1.06	1.06	1.06	1.06	1.06	1.06	1.06
	CMP	0.87	0.87	0.87	0.87	0.87	0.87	0.87	0.87	0.87	0.87	0.87	0.88
75 (23.9)	LDB	47.2	50.5	55.1	59.8	49.4	52.3	56.8	61.5	51.9	54.2	58.7	63.2
	LWB	42.5	47.4	52.9	58.6	43.6	48.8	54.3	60.0	44.8	50.3	55.8	61.4
	TCG	15.6	17.4	19.0	20.5	16.4	17.8	19.4	20.8	17.1	18.2	19.7	21.1
	SHG	14.9	14.6	12.6	10.4	16.4	15.3	13.1	10.7	17.1	16.2	13.7	11.0
	TC	15.4	17.2	18.8	20.3	16.2	17.5	19.1	20.6	16.9	17.9	19.5	20.9
	kW	1.17	1.19	1.19	1.19	1.18	1.18	1.19	1.19	1.18	1.19	1.19	1.19
85 (29.4)	CMP	0.99	1.00	1.00	1.00	0.99	1.00	1.00	1.01	1.00	1.00	1.00	1.01
	LDB	50.3	51.1	55.4	60.1	50.4	52.7	57.0	61.7	52.8	54.4	58.7	63.3
	LWB	43.3	48.1	53.4	59.0	44.1	49.4	54.8	60.3	45.3	50.8	56.1	61.7
	TCG	14.8	16.5	18.2	19.8	15.6	16.9	18.6	20.1	16.4	17.2	18.9	20.5
	SHG	14.8	13.9	12.2	10.2	15.6	14.8	12.9	10.5	16.4	15.8	13.6	10.9
	TC	14.5	16.2	18.0	19.6	15.4	16.6	18.3	19.9	16.1	17.0	18.6	20.2
95 (35)	kW	1.30	1.32	1.33	1.33	1.31	1.32	1.33	1.33	1.32	1.33	1.33	1.34
	CMP	1.12	1.13	1.15	1.15	1.13	1.14	1.15	1.15	1.14	1.14	1.15	1.15
	LDB	50.4	52.4	56.1	60.5	52.0	53.6	57.4	62.0	53.9	55.0	59.0	63.5
	LWB	44.1	49.0	54.1	59.5	44.9	50.2	55.3	60.7	45.8	51.4	56.6	62.0
	TCG	14.2	15.4	17.2	19.0	14.7	15.7	17.6	19.3	15.5	16.1	18.3	19.6
	SHG	14.2	13.3	11.8	9.8	14.7	14.2	12.5	10.2	15.5	15.2	13.5	10.7
105 (40.6)	TC	13.9	15.2	17.0	18.7	14.5	15.5	17.3	19.0	15.2	15.9	18.0	19.3
	kW	1.53	1.54	1.56	1.57	1.53	1.54	1.57	1.57	1.54	1.55	1.57	1.57
	CMP	1.34	1.35	1.37	1.38	1.35	1.36	1.38	1.39	1.36	1.36	1.38	1.39
	LDB	51.6	53.6	57.0	61.3	53.6	54.7	58.1	62.5	55.4	56.0	59.5	63.8
	LWB	44.7	49.9	54.9	60.1	45.6	51.1	56.0	61.3	46.5	52.2	57.2	62.5
	TCG	13.3	14.2	16.0	17.9	13.9	14.5	16.3	18.2	14.5	15.1	16.6	18.5
115 (46.1)	SHG	13.3	12.7	11.2	9.4	13.9	13.5	11.8	9.8	14.5	13.4	12.6	10.3
	TC	13.1	13.9	15.7	17.6	13.6	14.2	16.0	17.9	14.3	14.9	16.4	18.2
	kW	1.60	1.61	1.63	1.66	1.61	1.61	1.64	1.66	1.62	1.62	1.64	1.66
	CMP	1.42	1.43	1.45	1.47	1.42	1.43	1.45	1.47	1.43	1.43	1.46	1.48
	LDB	53.4	54.8	58.2	62.0	55.1	56.0	59.3	63.2	57.0	58.9	60.4	64.4
	LWB	45.5	51.0	55.9	60.9	46.4	52.0	56.9	62.0	47.2	52.9	58.0	63.1
125 (51.7)	TCG	12.3	12.9	14.6	16.5	12.8	13.3	14.9	16.8	13.4	13.8	15.2	17.1
	SHG	12.3	11.6	10.4	8.9	12.8	12.1	11.1	9.3	13.4	12.5	11.9	9.8
	TC	12.1	12.7	14.4	16.3	12.6	13.1	14.7	16.6	13.2	13.5	14.9	16.9
	kW	1.77	1.77	1.79	1.83	1.78	1.77	1.80	1.83	1.78	1.79	1.80	1.84
	CMP	1.58	1.58	1.61	1.64	1.59	1.59	1.61	1.65	1.60	1.60	1.62	1.66
	LDB	55.4	57.0	59.7	63.1	57.0	58.5	60.6	64.0	58.7	60.4	61.5	65.1
125 (51.7)	LWB	46.5	52.1	56.9	61.8	47.3	52.9	57.9	62.8	48.1	53.8	58.9	63.8
	TCG	11.2	11.6	13.1	14.9	11.7	11.8	13.3	15.2	12.3	12.3	13.6	15.5
	SHG	11.2	10.8	9.8	8.2	11.7	11.8	10.5	8.7	12.3	12.3	11.2	9.2
	TC	11.0	11.3	12.9	14.7	11.5	11.5	13.1	14.9	12.0	12.0	13.3	15.2
	kW	1.96	1.94	1.97	2.01	1.95	1.95	1.97	2.01	1.96	1.96	1.98	2.01
	CMP	1.77	1.76	1.78	1.82	1.77	1.76	1.79	1.83	1.78	1.77	1.79	1.83
125 (51.7)	LDB	57.7	58.6	60.9	64.4	59.0	59.1	61.7	65.2	60.6	60.7	62.6	66.1
	LWB	47.6	53.2	58.1	62.9	48.2	53.9	58.9	63.8	48.9	54.7	59.8	64.7

Rating Condition.
Not recommended for long-term operation

- BF – Bypass Factor
- CMP – Compressor
- Edb – Entering Dry Bulb
- Ewb – Entering Wet Bulb
- kW – Total Power
- LDB – Leaving Dry Bulb
- LWB – Leaving Wet Bulb
- SHG – Gross Sensible Capacity (1000 Btuh)
- TC – Total Net Cooling Capacity (1000 Btuh)
- TCG – Gross Cooling Capacity (1000 Btuh)

* The 40QAC024 unit must be field configured to an 018 size unit by changing the motor speed fan tap plug. Refer to Installation Instructions for more details.

NOTES:

1. Direct interpolation is permissible. Do not extrapolate.
2. The SHG is based on 80°F (26.7°C) edb temperature of air entering indoor coil.

Below 80°F (26.7°C) edb, subtract (corr factor x cfm) from SHG.

Above 80°F (26.7°C) edb, add (corr factor x cfm) to SHG.

Correction Factor = 1.10 x (1 - BF) x (edb - 80).

PERFORMANCE DATA (CONT.)

COOLING CAPACITIES 38HDR024 / 40QAC024

Temp ° F (° C) Air Entering Condenser (Edb)	Air Entering Evaporator – Cfm/BF												
	400/0.03				500/0.03				600/0.04				
	Air Entering Evaporator – Ewb ° F (° C)												
	57 (13.9)	62 (16.7)	67 (19.4)	72 (22.2)	57 (13.9)	62 (16.7)	67 (19.4)	72 (22.2)	57 (13.9)	62 (16.7)	67 (19.4)	72 (22.2)	
55 (12.8)	TCG	22.1	24.2	25.3	26.2	22.3	24.3	25.4	26.2	22.8	24.7	25.5	26.3
	SHG	21.1	19.1	16.0	12.9	21.5	19.3	16.1	13.0	22.8	20.0	16.3	13.1
	TC	21.8	23.8	25.0	25.8	21.9	24.0	25.0	25.9	22.5	24.4	25.2	26.0
	kW	1.19	1.19	1.20	1.20	1.19	1.20	1.20	1.20	1.19	1.20	1.20	1.20
	CMP	1.00	1.01	1.02	1.02	1.00	1.01	1.02	1.02	1.00	1.02	1.02	1.02
	LDB	44.3	48.0	53.7	59.3	45.1	49.1	54.6	60.0	46.0	50.6	56.4	61.5
65 (18.3)	LWB	40.1	45.4	51.5	57.8	40.8	46.0	52.1	58.4	41.9	47.2	53.5	59.7
	TCG	21.6	23.6	25.5	26.4	21.8	23.8	25.5	26.4	22.2	24.3	25.7	26.6
	SHG	20.9	19.0	16.3	13.2	21.3	19.4	16.4	13.2	22.1	20.1	16.8	13.4
	TC	21.2	23.3	25.1	26.1	21.4	23.5	25.2	26.1	21.8	24.0	25.4	26.3
	kW	1.35	1.35	1.36	1.37	1.35	1.35	1.36	1.37	1.35	1.36	1.36	1.37
	CMP	1.16	1.17	1.17	1.18	1.16	1.17	1.18	1.18	1.16	1.17	1.18	1.19
75 (23.9)	LDB	44.6	48.3	53.2	58.8	45.3	48.8	54.0	59.5	47.1	50.3	55.6	61.0
	LWB	40.6	45.8	51.4	57.7	41.2	46.3	52.0	58.3	42.4	47.5	53.3	59.5
	TCG	20.9	22.9	25.0	26.4	21.1	23.1	25.1	26.5	21.8	23.5	25.5	26.7
	SHG	20.2	18.7	16.1	13.2	20.4	19.0	16.4	13.4	21.5	20.0	17.0	13.6
	TC	20.6	22.5	24.6	26.1	20.8	22.7	24.8	26.2	21.5	23.2	25.2	26.4
	kW	1.51	1.53	1.54	1.55	1.52	1.53	1.54	1.55	1.53	1.53	1.54	1.55
85 (29.4)	CMP	1.33	1.35	1.35	1.36	1.33	1.35	1.35	1.36	1.34	1.35	1.35	1.37
	LDB	45.9	48.8	53.5	58.7	46.8	49.4	54.0	59.3	47.9	50.6	55.4	60.7
	LWB	41.2	46.4	51.7	57.7	41.7	46.9	52.3	58.2	42.7	48.1	53.5	59.5
	TCG	20.0	21.9	24.1	26.0	20.2	22.1	24.3	26.2	21.0	22.5	24.7	26.4
	SHG	20.0	18.3	15.8	13.1	20.2	18.6	16.1	13.2	21.0	19.5	16.7	13.5
	TC	19.7	21.6	23.8	25.7	19.9	21.8	24.0	25.8	20.6	22.2	24.3	26.1
95 (35)	kW	1.69	1.72	1.73	1.74	1.70	1.73	1.74	1.75	1.71	1.73	1.74	1.75
	CMP	1.51	1.54	1.55	1.56	1.51	1.54	1.55	1.56	1.53	1.54	1.55	1.56
	LDB	46.3	49.5	54.0	59.0	47.2	50.0	54.5	59.5	48.8	51.2	55.7	60.8
	LWB	42.0	47.1	52.3	57.9	42.5	47.6	52.9	58.5	43.3	48.7	54.0	59.6
	TCG	19.2	20.8	23.1	25.2	19.5	21.0	23.2	25.3	20.1	21.4	23.3	25.6
	SHG	19.2	17.7	15.4	12.8	19.5	18.0	15.7	12.9	20.1	18.9	16.1	13.3
105 (40.6)	TC	18.9	20.5	22.7	24.8	19.1	20.7	22.9	25.0	19.7	21.0	23.0	25.2
	kW	1.89	1.92	1.95	1.96	1.89	1.92	1.95	1.96	1.91	1.93	2.00	2.01
	CMP	1.70	1.73	1.76	1.77	1.71	1.73	1.76	1.77	1.72	1.74	1.82	1.83
	LDB	47.6	50.5	54.7	59.4	48.4	51.0	55.2	60.0	50.1	52.1	56.3	61.2
	LWB	42.7	48.0	53.1	58.5	43.1	48.5	53.6	59.0	44.0	49.5	54.6	60.1
	TCG	18.2	19.5	21.8	24.1	18.5	19.7	22.0	24.2	19.1	20.1	22.3	24.5
115 (46.1)	SHG	18.2	17.0	14.8	12.4	18.5	17.4	15.1	12.6	19.1	18.2	15.8	13.0
	TC	17.9	19.2	21.5	23.7	18.2	19.4	21.6	23.9	18.8	19.7	22.0	24.2
	kW	2.10	2.12	2.17	2.19	2.10	2.12	2.17	2.19	2.11	2.13	2.18	2.20
	CMP	1.91	1.93	1.98	2.01	1.92	1.94	1.99	2.01	1.93	1.95	2.00	2.01
	LDB	49.3	51.6	55.7	60.1	50.0	52.0	56.1	60.6	51.6	53.1	57.0	61.6
	LWB	43.6	49.0	54.0	59.2	43.9	49.4	54.4	59.6	44.7	50.4	55.4	60.6
125 (51.7)	TCG	17.1	18.1	20.4	22.7	17.4	18.3	20.5	22.8	18.0	19.0	20.9	23.2
	SHG	17.1	16.3	14.2	11.9	17.4	16.7	14.4	12.1	18.0	17.0	15.1	12.5
	TC	16.8	17.8	20.0	22.4	17.1	17.9	20.2	22.5	17.7	18.6	20.5	22.8
	kW	2.32	2.34	2.39	2.44	2.33	2.34	2.40	2.44	2.34	2.35	2.41	2.45
	CMP	2.13	2.15	2.21	2.26	2.14	2.16	2.21	2.26	2.15	2.16	2.22	2.26
	LDB	51.1	52.8	56.7	60.9	51.8	53.2	57.2	61.4	53.2	55.0	58.1	62.3
125 (51.7)	LWB	44.5	50.1	55.0	60.0	44.8	50.5	55.4	60.4	45.5	51.1	56.2	61.4
	TCG	15.9	16.8	18.7	21.1	16.2	17.1	18.9	21.3	16.8	17.4	19.3	21.5
	SHG	15.9	15.0	13.4	11.3	16.2	15.2	13.7	11.5	16.8	16.0	14.4	11.9
	TC	15.6	16.5	18.3	20.8	15.9	16.8	18.6	20.9	16.5	17.1	18.9	21.2
	kW	2.56	2.56	2.62	2.71	2.56	2.57	2.63	2.71	2.58	2.59	2.64	2.71
	CMP	2.37	2.38	2.44	2.52	2.38	2.39	2.44	2.52	2.39	2.40	2.46	2.53
125 (51.7)	LDB	53.2	55.0	58.0	61.9	53.7	55.6	58.3	62.2	55.1	56.5	59.1	63.1
	LWB	45.4	51.1	56.1	60.9	45.7	51.3	56.4	61.3	46.4	52.1	57.2	62.2

Rating Condition.
Not recommended for long-term operation

- BF – Bypass Factor
- CMP – Compressor
- Edb – Entering Dry Bulb
- Ewb – Entering Wet Bulb
- kW – Total Power
- LDB – Leaving Dry Bulb
- LWB – Leaving Wet Bulb
- SHG – Gross Sensible Capacity (1000 Btuh)
- TC – Total Net Cooling Capacity (1000 Btuh)
- TCG – Gross Cooling Capacity (1000 Btuh)

NOTES:

1. Direct interpolation is permissible. Do not extrapolate.
2. The SHG is based on 80°F (26.7°C) edb temperature of air entering indoor coil.

Below 80°F (26.7°C) edb, subtract (corr factor x cfm) from SHG.
Above 80°F (26.7°C) edb, add (corr factor x cfm) to SHG.
Correction Factor = 1.10 x (1 – BF) x (edb – 80).

40QAC/38HDR – 40QAC/38GRF

PERFORMANCE DATA (CONT.)

COOLING CAPACITIES 38HDR030 / 40QAC036

Temp °F (°C) Air Entering Condenser (Edb)		Air Entering Evaporator – Cfm/BF											
		640/0.02				740/0.02				840/0.03			
		Air Entering Evaporator – Ewb °F (°C)											
		57 (13.9)	62 (16.7)	67 (19.4)	72 (22.2)	57 (13.9)	62 (16.7)	67 (19.4)	72 (22.2)	57 (13.9)	62 (16.7)	67 (19.4)	72 (22.2)
55 (12.8)	TCG	29.0	31.4	33.0	34.1	29.8	31.8	33.2	34.2	30.6	32.0	33.4	34.3
	SHG	28.0	25.8	21.4	17.1	28.5	26.5	21.9	17.3	30.6	27.4	22.2	17.5
	TC	28.2	30.6	32.2	33.3	29.1	31.1	32.5	33.5	29.8	31.3	32.6	33.6
	kW	1.57	1.57	1.58	1.58	1.56	1.57	1.58	1.58	1.57	1.58	1.59	1.58
	CMP	1.22	1.22	1.23	1.23	1.21	1.22	1.23	1.23	1.22	1.23	1.24	1.23
	LDB	47.4	50.3	55.8	61.2	49.9	52.3	57.6	62.8	50.4	53.7	59.2	64.1
65 (18.3)	LWB	42.0	47.3	53.3	59.5	43.1	48.7	54.6	60.8	44.1	49.9	55.8	61.8
	TCG	28.6	30.9	33.1	34.4	29.3	31.4	33.3	34.6	30.2	31.9	33.6	34.8
	SHG	27.5	26.0	21.8	17.6	29.3	27.1	22.5	17.8	30.2	28.1	23.2	18.0
	TC	27.8	30.2	32.3	33.7	28.6	30.7	32.5	33.9	29.4	31.1	32.8	34.0
	kW	1.74	1.74	1.74	1.76	1.73	1.74	1.75	1.76	1.74	1.74	1.75	1.76
	CMP	1.39	1.39	1.39	1.41	1.38	1.39	1.40	1.41	1.39	1.39	1.40	1.41
75 (23.9)	LDB	48.0	50.1	55.4	60.7	49.0	51.6	56.9	62.2	50.8	53.1	58.2	63.5
	LWB	42.3	47.6	53.2	59.3	43.4	48.9	54.6	60.6	44.3	49.9	55.7	61.6
	TCG	27.7	29.9	32.5	34.6	28.6	30.5	33.0	34.8	29.5	30.9	33.4	34.9
	SHG	27.7	25.6	21.9	17.7	28.6	26.9	22.7	18.1	29.5	28.1	23.5	18.5
	TC	26.9	29.2	31.8	33.8	27.9	29.7	32.2	34.1	28.8	30.2	32.6	34.2
	kW	1.92	1.93	1.93	1.95	1.93	1.93	1.93	1.95	1.93	1.94	1.93	1.96
85 (29.4)	CMP	1.57	1.58	1.58	1.60	1.58	1.58	1.58	1.60	1.58	1.59	1.58	1.61
	LDB	47.8	50.5	55.3	60.6	49.7	51.9	56.7	61.9	51.4	53.1	57.9	63.1
	LWB	42.8	48.1	53.5	59.3	43.8	49.3	54.7	60.5	44.6	50.3	55.8	61.6
	TCG	26.7	28.7	31.4	33.9	27.7	29.2	31.9	34.2	28.5	29.7	32.3	34.4
	SHG	26.7	24.9	21.6	17.5	27.7	26.3	22.4	18.0	28.5	27.5	23.3	18.5
	TC	26.0	28.0	30.7	33.1	26.9	28.4	31.2	33.5	27.8	28.9	31.6	33.7
95 (35)	kW	2.12	2.14	2.16	2.17	2.13	2.15	2.16	2.17	2.15	2.15	2.16	2.17
	CMP	1.77	1.79	1.81	1.82	1.78	1.80	1.81	1.82	1.80	1.80	1.81	1.82
	LDB	48.9	51.3	55.6	60.7	50.8	52.5	57.0	62.0	52.5	53.6	58.1	63.0
	LWB	43.4	48.8	54.0	59.6	44.3	50.0	55.2	60.7	45.1	50.9	56.1	61.7
	TCG	25.6	27.2	28.9	32.9	26.5	27.7	29.5	33.3	27.3	28.1	29.8	33.6
	SHG	25.6	24.0	20.1	17.3	26.5	25.4	21.1	17.8	27.3	26.5	22.8	18.3
105 (40.6)	TC	24.8	26.4	28.2	32.1	25.7	26.9	28.7	32.5	26.6	27.3	29.0	32.8
	kW	2.34	2.36	2.39	2.40	2.35	2.37	2.40	2.42	2.38	2.37	2.42	2.42
	CMP	1.99	2.01	2.04	2.05	2.00	2.02	2.05	2.07	2.03	2.02	2.07	2.07
	LDB	50.3	52.3	56.4	61.0	52.1	53.5	57.5	62.2	53.6	54.6	58.5	63.3
	LWB	44.0	49.6	54.6	60.0	44.9	50.7	55.8	61.1	45.7	51.6	56.7	62.0
	TCG	24.3	25.5	28.4	31.4	25.1	25.9	28.9	31.8	25.9	26.4	29.3	32.2
115 (46.1)	SHG	24.3	23.2	20.1	16.8	25.1	24.4	21.2	17.4	25.9	25.6	22.1	18.0
	TC	23.5	24.7	27.7	30.7	24.4	25.2	28.1	31.1	25.2	25.6	28.5	31.5
	kW	2.59	2.60	2.64	2.67	2.59	2.60	2.65	2.67	2.60	2.61	2.65	2.68
	CMP	2.24	2.25	2.29	2.32	2.24	2.25	2.30	2.32	2.25	2.26	2.30	2.33
	LDB	51.8	53.3	57.3	61.6	53.5	54.5	58.3	62.6	55.0	55.5	59.2	63.6
	LWB	44.8	50.5	55.5	60.6	45.6	51.5	56.5	61.6	46.3	52.3	57.3	62.5
125 (51.7)	TCG	22.8	23.5	26.4	29.7	23.7	24.4	26.9	30.1	24.4	24.9	27.2	30.4
	SHG	22.8	22.3	19.2	16.1	23.7	22.6	20.2	16.8	24.4	23.4	21.1	17.4
	TC	22.1	22.8	25.7	28.9	22.9	23.7	26.1	29.3	23.6	24.2	26.5	29.7
	kW	2.83	2.85	2.89	2.95	2.86	2.86	2.90	2.96	2.86	2.87	2.91	2.97
	CMP	2.48	2.50	2.54	2.60	2.51	2.51	2.55	2.61	2.51	2.52	2.56	2.62
	LDB	53.6	54.4	58.4	62.3	55.1	56.4	59.3	63.2	56.6	57.7	60.1	64.1
125 (51.7)	LWB	45.6	51.5	56.4	61.3	46.4	52.2	57.3	62.3	47.0	52.9	58.1	63.1
	TCG	21.2	21.7	24.1	27.4	22.0	22.2	24.5	27.8	22.7	22.7	24.9	28.1
	SHG	21.2	20.6	18.1	15.1	22.0	21.6	19.1	15.8	22.7	22.7	20.1	16.5
	TC	20.5	21.0	23.4	26.6	21.3	21.4	23.8	27.1	22.0	21.9	24.1	27.3
	kW	3.12	3.12	3.17	3.24	3.14	3.14	3.18	3.25	3.16	3.15	3.19	3.26
	CMP	2.77	2.77	2.82	2.89	2.79	2.79	2.83	2.90	2.81	2.80	2.84	2.91
125 (51.7)	LDB	55.5	56.4	59.6	63.4	56.9	57.5	60.4	64.3	58.2	58.4	61.2	65.0
	LWB	46.5	52.4	57.4	62.3	47.2	53.2	58.2	63.1	47.8	53.8	58.9	63.8

Rating Condition.
Not recommended for long-term operation

- BF – Bypass Factor
- CMP – Compressor
- Edb – Entering Dry Bulb
- Ewb – Entering Wet Bulb
- kW – Total Power
- LDB – Leaving Dry Bulb
- LWB – Leaving Wet Bulb
- SHG – Gross Sensible Capacity (1000 Btuh)
- TC – Total Net Cooling Capacity (1000 Btuh)
- TCG – Gross Cooling Capacity (1000 Btuh)

NOTES:

1. Direct interpolation is permissible. Do not extrapolate.
2. The SHG is based on 80°F (26.7°C) edb temperature of air entering indoor coil.

Below 80°F (26.7°C) edb, subtract (corr factor x cfm) from SHG.
Above 80°F (26.7°C) edb, add (corr factor x cfm) to SHG.
Correction Factor = 1.10 x (1 – BF) x (edb – 80).

PERFORMANCE DATA (CONT.)

COOLING CAPACITIES 38HDR036 / 40QAC036

Temp °F (°C) Air Entering Condenser (Edb)		Air Entering Evaporator – Cfm/BF											
		640/0.02				740/0.02				840/0.03			
		Air Entering Evaporator – Ewb °F (°C)											
		57 (13.9)	62 (16.7)	67 (19.4)	72 (22.2)	57 (13.9)	62 (16.7)	67 (19.4)	72 (22.2)	57 (13.9)	62 (16.7)	67 (19.4)	72 (22.2)
55 (12.8)	TCG	31.6	34.2	35.6	36.5	32.3	34.7	35.7	36.6	32.9	35.0	35.9	36.6
	SHG	30.5	27.2	22.6	18.1	32.3	28.2	22.9	18.2	32.9	29.0	23.3	18.4
	TC	30.9	33.5	34.9	35.7	31.6	34.0	35.0	35.8	32.2	34.3	35.1	35.9
	kW	1.74	1.74	1.75	1.74	1.74	1.75	1.75	1.74	1.73	1.75	1.75	1.74
	CMP	1.39	1.39	1.40	1.39	1.39	1.40	1.40	1.39	1.38	1.40	1.40	1.39
	LDB	43.8	48.1	54.0	59.7	45.2	50.0	56.1	61.5	47.6	51.8	57.8	62.9
65 (18.3)	LWB	40.0	45.4	51.6	58.1	41.5	47.0	53.3	59.6	42.7	48.3	54.6	60.8
	TCG	30.8	33.6	36.0	37.1	31.5	34.2	36.3	37.3	32.4	34.7	36.5	37.5
	SHG	30.0	27.1	23.1	18.6	31.4	28.4	23.8	18.9	32.4	29.4	24.4	19.1
	TC	30.0	32.8	35.2	36.4	30.8	33.5	35.6	36.5	31.7	34.0	35.8	36.8
	kW	1.95	1.94	1.95	1.95	1.95	1.94	1.95	1.95	1.95	1.95	1.95	1.95
	CMP	1.60	1.59	1.60	1.60	1.60	1.59	1.60	1.60	1.60	1.60	1.60	1.60
75 (23.9)	LDB	44.3	48.1	53.3	59.1	46.2	49.8	55.1	60.8	48.1	51.4	56.7	62.2
	LWB	40.6	45.8	51.4	57.8	41.9	47.2	53.0	59.3	43.0	48.4	54.3	60.5
	TCG	30.2	32.6	35.3	37.0	31.2	33.2	35.8	37.2	31.7	33.7	36.2	37.3
	SHG	29.0	26.7	22.9	18.7	29.7	28.1	23.8	19.0	31.7	29.2	24.5	19.3
	TC	29.4	31.8	34.5	36.3	30.5	32.4	35.0	36.4	31.0	33.0	35.4	36.6
	kW	2.18	2.17	2.17	2.18	2.18	2.18	2.17	2.18	2.18	2.17	2.18	2.18
85 (29.4)	CMP	1.83	1.82	1.82	1.83	1.83	1.83	1.82	1.83	1.83	1.82	1.83	1.83
	LDB	45.6	48.6	53.5	59.1	48.1	50.1	55.2	60.7	48.8	51.5	56.6	62.1
	LWB	40.9	46.4	51.8	57.9	42.1	47.7	53.2	59.4	43.3	48.9	54.4	60.6
	TCG	28.8	31.3	34.3	36.7	29.6	31.9	34.8	36.9	30.7	32.4	35.2	37.1
	SHG	28.2	26.0	22.7	18.5	29.6	27.4	23.6	19.0	30.7	28.8	24.4	19.4
	TC	28.0	30.5	33.5	35.9	28.9	31.2	34.1	36.2	30.0	31.7	34.5	36.4
95 (35)	kW	2.40	2.42	2.43	2.43	2.42	2.43	2.43	2.44	2.43	2.43	2.43	2.44
	CMP	2.05	2.07	2.08	2.08	2.07	2.08	2.08	2.09	2.08	2.08	2.08	2.09
	LDB	46.5	49.5	53.9	59.2	48.1	50.8	55.3	60.7	49.8	52.0	56.7	61.9
	LWB	41.8	47.1	52.3	58.1	43.0	48.4	53.7	59.5	43.8	49.5	54.8	60.6
	TCG	27.3	29.7	32.9	35.7	28.3	30.3	33.4	36.2	29.3	30.8	33.7	36.5
	SHG	27.3	25.1	22.0	18.3	28.3	26.5	23.0	18.8	29.3	27.8	23.9	19.3
105 (40.6)	TC	26.6	28.9	32.1	35.0	27.6	29.6	32.7	35.4	28.5	30.1	33.0	35.8
	kW	2.84	2.85	2.89	2.89	2.85	2.86	2.89	2.90	2.86	2.87	2.89	2.90
	CMP	2.49	2.50	2.54	2.54	2.50	2.51	2.54	2.55	2.51	2.52	2.54	2.55
	LDB	47.6	50.6	54.6	59.5	49.6	51.8	55.9	60.9	51.3	53.0	57.0	62.1
	LWB	42.7	48.0	53.0	58.5	43.7	49.2	54.3	59.8	44.5	50.2	55.3	60.8
	TCG	25.9	27.8	31.1	34.3	26.9	28.4	31.7	34.8	27.8	28.9	32.2	35.2
115 (46.1)	SHG	25.9	24.1	21.1	17.8	26.9	25.5	22.2	18.4	27.8	26.8	23.3	18.9
	TC	25.1	27.0	30.3	33.6	26.2	27.7	31.0	34.1	27.0	28.2	31.4	34.5
	kW	2.94	2.95	2.99	3.02	2.95	2.96	3.01	3.02	2.96	2.97	3.02	3.02
	CMP	2.59	2.60	2.64	2.67	2.60	2.61	2.66	2.67	2.61	2.62	2.67	2.67
	LDB	49.4	51.7	55.7	60.1	51.1	52.9	56.8	61.3	52.8	54.0	57.7	62.4
	LWB	43.6	49.0	53.9	59.1	44.5	50.1	55.0	60.3	45.2	51.0	56.0	61.3
125 (51.7)	TCG	24.4	25.7	29.0	32.5	25.3	26.3	29.6	33.0	26.2	27.4	29.9	33.4
	SHG	24.4	23.3	20.1	17.1	25.3	24.5	21.2	17.7	26.2	24.6	22.1	18.4
	TC	23.6	25.0	28.2	31.7	24.6	25.5	28.8	32.2	25.4	26.6	29.2	32.6
	kW	3.24	3.25	3.30	3.36	3.25	3.26	3.31	3.36	3.27	3.26	3.31	3.36
	CMP	2.89	2.90	2.95	3.01	2.90	2.91	2.96	3.01	2.92	2.91	2.96	3.01
	LDB	51.2	52.8	56.9	60.9	52.9	54.0	57.9	62.0	54.4	56.1	58.9	62.9
125 (51.7)	LWB	44.5	50.1	54.9	59.9	45.3	51.1	56.0	61.0	46.0	51.7	56.9	61.9
	TCG	22.8	23.9	26.6	30.2	23.6	24.8	27.1	30.7	24.4	25.2	27.6	31.1
	SHG	22.8	21.5	19.0	16.2	23.6	22.3	20.1	16.9	24.4	23.4	21.1	17.5
	TC	22.0	23.1	25.8	29.5	22.9	24.0	26.4	30.0	23.7	24.4	26.8	30.3
	kW	3.57	3.56	3.62	3.71	3.59	3.58	3.64	3.72	3.60	3.59	3.65	3.72
	CMP	3.22	3.21	3.27	3.36	3.24	3.23	3.29	3.37	3.25	3.24	3.30	3.37
125 (51.7)	LDB	53.2	55.0	58.2	61.9	54.8	56.4	59.0	62.8	56.2	57.4	59.8	63.7
	LWB	45.4	51.1	56.1	60.9	46.2	51.8	57.0	61.9	46.9	52.6	57.8	62.7

Rating Condition.
Not recommended for long-term operation

- BF – Bypass Factor
- CMP – Compressor
- Edb – Entering Dry Bulb
- Ewb – Entering Wet Bulb
- kW – Total Power
- LDB – Leaving Dry Bulb
- LWB – Leaving Wet Bulb
- SHG – Gross Sensible Capacity (1000 Btuh)
- TC – Total Net Cooling Capacity (1000 Btuh)
- TCG – Gross Cooling Capacity (1000 Btuh)

NOTES:

1. Direct interpolation is permissible. Do not extrapolate.
2. The SHG is based on 80°F (26.7°C) edb temperature of air entering indoor coil.

Below 80°F (26.7°C) edb, subtract (corr factor x cfm) from SHG.
Above 80°F (26.7°C) edb, add (corr factor x cfm) to SHG.
Correction Factor = 1.10 x (1 – BF) x (edb – 80).

40QAC/38HDR – 40QAC/38QRH

PERFORMANCE DATA (CONT.)

COOLING CAPACITIES 38HDR048 / 40QAC048

Temp °F (°C) Air Entering Condenser (Edb)		Air Entering Evaporator – Cfm/BF											
		1100/0.05				1160/0.05				1200/0.06			
		Air Entering Evaporator – Ewb °F (°C)											
		57 (13.9)	62 (16.7)	67 (19.4)	72 (22.2)	57 (13.9)	62 (16.7)	67 (19.4)	72 (22.2)	57 (13.9)	62 (16.7)	67 (19.4)	72 (22.2)
55 (12.8)	TCG	44.2	45.6	47.0	48.2	44.6	45.9	47.3	48.5	44.9	46.1	47.5	48.6
	SHG	44.2	36.9	30.7	25.4	44.6	37.5	31.1	25.6	44.9	38.0	31.3	25.8
	TC	43.0	44.5	45.9	47.1	43.4	44.8	46.2	47.3	43.7	45.0	46.3	47.5
	kW	2.42	2.42	2.42	2.42	2.42	2.42	2.42	2.42	2.42	2.42	2.42	2.42
	CMP	2.07	2.07	2.07	2.07	2.07	2.07	2.07	2.07	2.07	2.07	2.07	2.07
	LDB	42.5	49.1	54.8	59.7	44.7	50.7	56.2	60.9	46.0	51.7	57.1	61.6
65 (18.3)	LWB	40.1	46.4	52.7	59.0	41.2	47.5	53.7	60.0	41.9	48.1	54.3	60.5
	TCG	44.8	46.4	48.1	49.6	45.4	46.8	48.4	49.9	45.8	47.0	48.6	50.0
	SHG	44.8	38.7	31.9	26.1	45.4	39.6	32.4	26.3	45.8	40.1	32.7	26.5
	TC	43.7	45.3	47.0	48.5	44.3	45.7	47.3	48.7	44.6	45.9	47.5	48.9
	kW	2.74	2.75	2.75	2.76	2.74	2.75	2.75	2.76	2.74	2.75	2.75	2.76
	CMP	2.39	2.40	2.40	2.41	2.39	2.40	2.40	2.41	2.39	2.40	2.40	2.41
75 (23.9)	LDB	41.9	47.5	53.8	59.1	44.0	49.0	55.2	60.3	45.3	50.0	56.0	61.1
	LWB	39.8	46.0	52.3	58.6	40.9	47.1	53.3	59.6	41.6	47.8	54.0	60.2
	TCG	44.5	46.2	48.4	50.3	45.3	46.6	48.7	50.6	46.0	46.9	49.0	50.8
	SHG	44.5	39.6	32.6	26.5	45.3	40.6	33.3	26.8	46.0	41.3	33.7	27.1
	TC	43.4	45.0	47.2	49.2	44.1	45.5	47.6	49.4	44.9	45.7	47.8	49.6
	kW	3.08	3.10	3.12	3.12	3.09	3.10	3.12	3.12	3.09	3.11	3.12	3.12
85 (29.4)	CMP	2.73	2.75	2.77	2.77	2.74	2.75	2.77	2.77	2.74	2.76	2.77	2.77
	LDB	42.2	46.7	53.1	58.7	44.2	48.2	54.4	59.9	45.1	49.0	55.2	60.6
	LWB	39.9	46.1	52.2	58.4	41.0	47.2	53.2	59.4	41.5	47.9	53.8	59.9
	TCG	43.2	45.4	48.0	50.1	44.3	46.0	48.4	50.5	45.0	46.2	48.6	50.7
	SHG	43.2	39.8	33.0	26.6	44.3	41.2	33.8	27.0	45.0	42.1	34.3	27.3
	TC	42.1	44.3	46.8	49.0	43.1	44.8	47.2	49.3	43.9	45.0	47.4	49.5
95 (35)	kW	3.47	3.48	3.51	3.53	3.48	3.49	3.51	3.53	3.48	3.49	3.52	3.53
	CMP	3.12	3.13	3.16	3.18	3.13	3.14	3.16	3.18	3.13	3.14	3.17	3.18
	LDB	43.3	46.5	52.8	58.6	44.9	47.7	54.0	59.8	45.9	48.4	54.8	60.5
	LWB	40.5	46.4	52.3	58.4	41.4	47.4	53.3	59.4	41.9	48.1	54.0	60.0
	TCG	41.3	43.3	46.4	49.7	42.4	44.1	46.8	50.0	43.2	44.5	47.1	50.2
	SHG	41.3	38.9	32.7	26.6	42.4	40.7	33.5	27.1	43.2	41.7	34.2	27.4
105 (40.6)	TC	40.1	42.2	45.3	48.5	41.3	43.0	45.6	48.9	42.1	43.4	46.0	49.1
	kW	3.84	3.89	3.99	4.03	3.87	3.90	3.99	4.03	3.89	3.90	4.00	4.03
	CMP	3.49	3.54	3.64	3.68	3.52	3.55	3.64	3.68	3.54	3.55	3.65	3.68
	LDB	45.0	47.3	52.6	58.6	46.5	48.1	53.7	59.7	47.3	48.7	54.4	60.3
	LWB	41.4	47.3	52.6	58.6	42.1	48.1	53.6	59.5	42.6	48.7	54.2	60.1
	TCG	39.1	40.6	45.3	48.7	40.3	41.2	45.8	49.1	41.0	41.6	46.1	49.3
115 (46.1)	SHG	39.1	37.7	32.4	26.3	40.3	39.3	33.5	27.0	41.0	40.4	34.3	27.4
	TC	38.0	39.5	44.1	47.6	39.2	40.1	44.6	47.9	39.9	40.5	44.9	48.1
	kW	4.24	4.27	4.38	4.44	4.26	4.29	4.39	4.44	4.29	4.30	4.40	4.45
	CMP	3.89	3.92	4.03	4.09	3.91	3.94	4.04	4.09	3.94	3.95	4.05	4.10
	LDB	46.9	48.3	53.3	58.9	48.2	49.2	54.2	59.8	49.0	49.7	54.7	60.3
	LWB	42.4	48.3	53.3	58.9	43.0	49.2	54.2	59.8	43.4	49.7	54.7	60.3
125 (51.7)	TCG	36.6	37.3	42.1	46.8	37.8	38.0	42.6	47.4	38.6	38.6	43.0	47.7
	SHG	36.6	36.2	31.0	25.6	37.8	37.8	32.2	26.3	38.6	38.6	33.0	26.8
	TC	35.5	36.1	40.9	45.7	36.7	36.9	41.5	46.2	37.4	37.5	41.8	46.5
	kW	4.67	4.68	4.82	4.92	4.70	4.70	4.84	4.93	4.72	4.72	4.85	4.94
	CMP	4.32	4.33	4.47	4.57	4.35	4.35	4.49	4.58	4.37	4.37	4.50	4.59
	LDB	49.1	49.6	54.4	59.5	50.2	50.4	55.2	60.3	50.9	51.0	55.7	60.8
125 (51.7)	LWB	43.4	49.6	54.4	59.5	44.0	50.3	55.2	60.3	44.4	50.7	55.7	60.8
	TCG	34.0	34.1	38.6	43.4	35.1	35.1	39.3	44.1	35.8	35.8	39.7	44.5
	SHG	34.0	34.1	29.6	24.3	35.1	35.1	30.9	25.1	35.8	35.8	31.7	25.7
	TC	32.8	32.9	37.5	42.3	33.9	34.0	38.1	43.0	34.6	34.7	38.6	43.4
	kW	5.13	5.13	5.25	5.42	5.16	5.16	5.27	5.44	5.18	5.18	5.29	5.45
	CMP	4.78	4.78	4.90	5.07	4.81	4.81	4.92	5.09	4.83	4.83	4.94	5.10
125 (51.7)	LDB	51.4	51.4	55.6	60.5	52.4	52.5	56.3	61.2	53.1	53.2	56.7	61.6
	LWB	44.6	50.9	55.6	60.5	45.1	51.3	56.3	61.2	45.4	51.6	56.7	61.6

Rating Condition.
Not recommended for long-term operation

BF – Bypass Factor
 CMP – Compressor
 Edb – Entering Dry Bulb
 Ewb – Entering Wet Bulb
 kW – Total Power
 LDB – Leaving Dry Bulb
 LWB – Leaving Wet Bulb
 SHG – Gross Sensible Capacity (1000 Btuh)
 TC – Total Net Cooling Capacity (1000 Btuh)
 TCG – Gross Cooling Capacity (1000 Btuh)

NOTES:

- Direct interpolation is permissible. Do not extrapolate.
- The SHG is based on 80°F (26.67°C) edb temperature of air entering indoor coil.
 Below 80°F (26.67°C) edb, subtract (corr factor x cfm) from SHG.
 Above 80°F (26.67°C) edb, add (corr factor x cfm) to SHG.
 Correction Factor = 1.10 x (1 – BF) x (edb – 80).

PERFORMANCE DATA (CONT.)

COOLING CAPACITIES 38HDR060 / 40QAC060

Temp °F (°C) Air Entering Condenser (Edb)		Air Entering Evaporator – Cfm/BF											
		1040/0.03				1220/0.04				1600/0.06			
		Air Entering Evaporator – Ewb (°F)											
		57 (13.9)	62 (16.7)	67 (19.4)	72 (22.2)	57 (13.9)	62 (16.7)	67 (19.4)	72 (22.2)	57 (13.9)	62 (16.7)	67 (19.4)	72 (22.2)
55 (12.8)	TCG	58.3	60.6	62.3	64.9	59.9	61.5	63.7	65.4	62.0	62.6	64.4	65.8
	SHG	58.3	51.4	41.3	34.1	59.9	53.8	43.9	34.8	62.0	57.5	45.9	35.8
	TC	57.1	59.4	61.1	63.7	58.7	60.3	62.4	64.2	60.8	61.4	63.1	64.6
	kW	3.02	3.05	3.08	3.10	3.05	3.07	3.09	3.10	3.08	3.09	3.09	3.10
	CMP	2.67	2.70	2.73	2.75	2.70	2.72	2.74	2.75	2.73	2.74	2.74	2.75
	LDB	39.6	44.8	52.2	57.6	42.4	46.6	53.3	59.3	47.6	50.2	56.6	62.3
65 (18.3)	LWB	38.5	44.8	51.3	57.6	40.0	46.4	52.7	59.0	42.7	49.1	55.2	61.4
	TCG	57.1	60.3	63.8	65.4	58.9	61.6	64.4	66.3	62.6	63.4	64.9	66.7
	SHG	57.1	51.2	43.3	34.1	58.9	54.1	45.2	35.1	62.6	59.9	46.5	36.4
	TC	55.8	59.1	62.6	64.2	57.7	60.4	63.2	65.0	61.3	62.2	63.7	65.5
	kW	3.39	3.40	3.47	3.49	3.41	3.44	3.48	3.50	3.45	3.46	3.48	3.50
	CMP	3.04	3.05	3.12	3.14	3.06	3.09	3.13	3.15	3.10	3.11	3.13	3.15
75 (23.9)	LDB	40.5	44.9	50.9	57.6	43.1	46.4	52.4	59.3	47.3	48.9	56.4	62.0
	LWB	39.0	44.9	50.9	57.4	40.4	46.4	52.5	58.8	42.6	48.9	55.1	61.2
	TCG	55.3	58.5	63.4	66.6	57.2	59.5	64.8	67.1	60.6	61.4	66.1	67.6
	SHG	55.3	50.3	43.1	34.8	57.2	53.1	45.2	35.9	60.6	59.0	49.3	37.6
	TC	54.0	57.2	62.1	65.4	56.0	58.2	63.5	65.9	59.4	60.2	64.9	66.4
	kW	3.79	3.82	3.88	3.93	3.80	3.84	3.90	3.94	3.85	3.86	3.92	3.94
85 (29.4)	CMP	3.44	3.47	3.53	3.58	3.45	3.49	3.55	3.59	3.50	3.51	3.57	3.59
	LDB	41.8	45.5	51.0	57.1	44.2	47.0	52.4	58.6	48.4	49.4	54.9	61.3
	LWB	39.7	45.5	51.0	57.1	41.0	47.0	52.4	58.6	43.1	49.4	54.9	61.0
	TCG	53.0	55.8	61.3	66.0	55.0	57.2	62.2	66.5	58.7	59.1	63.7	67.4
	SHG	53.0	49.0	42.2	34.6	55.0	52.0	44.1	35.7	58.7	58.0	48.3	38.0
	TC	51.8	54.6	60.1	64.8	53.8	56.0	61.0	65.3	57.4	57.9	62.5	66.2
95 (35)	kW	4.19	4.25	4.31	4.39	4.24	4.27	4.34	4.40	4.29	4.29	4.36	4.42
	CMP	3.84	3.90	3.96	4.04	3.89	3.92	3.99	4.05	3.94	3.94	4.01	4.07
	LDB	43.4	46.4	51.6	57.3	45.5	47.7	53.1	58.8	49.4	49.9	55.4	61.1
	LWB	40.5	46.4	51.6	57.3	41.7	47.7	53.1	58.8	43.6	49.9	55.4	61.1
	TCG	50.6	52.8	55.3	63.4	52.6	54.0	56.5	64.4	56.0	56.1	58.3	66.4
	SHG	50.6	47.6	38.9	33.6	52.6	50.5	40.9	34.9	56.0	56.1	45.1	37.7
105 (40.6)	TC	49.4	51.5	54.1	62.2	51.4	52.7	55.3	63.1	54.8	54.9	57.0	65.2
	kW	4.62	4.67	4.96	5.05	4.67	4.71	4.97	5.07	4.77	4.77	5.00	5.09
	CMP	4.27	4.32	4.61	4.70	4.32	4.36	4.62	4.72	4.42	4.42	4.65	4.74
	LDB	45.1	47.4	52.6	58.0	47.1	48.7	53.8	59.3	50.8	50.9	55.9	61.3
	LWB	41.4	47.4	52.6	58.0	42.5	48.6	53.8	59.3	44.3	50.6	55.9	61.3
	TCG	47.6	49.2	54.5	60.3	49.8	49.8	55.6	61.4	53.1	53.2	57.4	63.0
115 (46.1)	SHG	47.6	45.9	39.2	32.4	49.8	49.8	41.4	33.7	53.1	53.2	45.8	36.4
	TC	46.4	47.9	53.3	59.1	48.5	48.6	54.3	60.1	51.9	52.0	56.2	61.7
	kW	5.07	5.11	5.27	5.39	5.14	5.14	5.31	5.41	5.23	5.24	5.35	5.45
	CMP	4.72	4.76	4.92	5.04	4.79	4.79	4.96	5.06	4.88	4.89	5.00	5.10
	LDB	47.2	48.6	53.6	58.8	48.9	49.1	54.8	60.0	52.4	52.5	56.7	61.9
	LWB	42.5	48.6	53.6	58.8	43.4	49.8	54.8	60.0	45.0	51.3	56.7	61.9
125 (51.7)	TCG	44.6	44.7	50.4	56.4	46.7	46.6	51.5	57.5	49.9	49.9	53.4	59.2
	SHG	44.6	44.7	37.6	30.9	46.7	46.6	39.7	32.3	49.9	49.9	44.2	35.1
	TC	43.4	43.5	49.2	55.2	45.5	45.4	50.3	56.3	48.6	48.7	52.1	58.0
	kW	5.59	5.60	5.73	5.93	5.66	5.65	5.76	5.97	5.74	5.74	5.84	5.99
	CMP	5.24	5.25	5.38	5.58	5.31	5.30	5.41	5.62	5.39	5.39	5.49	5.64
	LDB	49.3	49.4	54.8	59.8	50.9	51.1	55.8	60.8	54.1	54.2	57.5	62.6
125 (51.7)	LWB	43.5	49.9	54.8	59.8	44.3	50.7	55.8	60.8	45.9	52.0	57.5	62.6
	TCG	41.4	41.5	45.8	52.2	43.2	43.1	46.8	53.2	46.2	46.2	48.7	54.6
	SHG	41.4	41.5	35.7	29.4	43.2	43.1	37.8	30.7	46.2	46.2	42.3	33.4
	TC	40.2	40.2	44.6	51.0	42.0	41.9	45.6	51.9	44.9	45.0	47.4	53.4
	kW	6.15	6.15	6.25	6.43	6.21	6.19	6.28	6.47	6.28	6.28	6.34	6.55
	CMP	5.80	5.80	5.90	6.08	5.86	5.84	5.93	6.12	5.93	5.93	5.99	6.20
125 (51.7)	LDB	51.5	51.7	56.0	60.8	53.1	53.3	56.9	61.8	56.1	56.2	58.4	63.4
	LWB	44.7	51.0	56.0	60.8	45.4	51.7	56.9	61.8	46.8	52.9	58.4	63.4

Rating Condition.
Not recommended for long-term operation

BF – Bypass Factor
 CMP – Compressor
 Edb – Entering Dry Bulb
 Ewb – Entering Wet Bulb
 kW – Total Power
 LDB – Leaving Dry Bulb
 LWB – Leaving Wet Bulb
 SHG – Gross Sensible Capacity (1000 Btuh)
 TC – Total Net Cooling Capacity (1000 Btuh)
 TCG – Gross Cooling Capacity (1000 Btuh)

NOTES:

- Direct interpolation is permissible. Do not extrapolate.
- The SHG is based on 80°F (26.67°C) edb temperature of air entering indoor coil.
 Below 80°F (26.67°C) edb, subtract (corr factor x cfm) from SHG.
 Above 80°F (26.67°C) edb, add (corr factor x cfm) to SHG.
 Correction Factor = 1.10 x (1 - BF) x (edb - 80).

40QAC/38HDR - 40QAC/38QRH

PERFORMANCE DATA (CONT.)

COOLING CAPACITIES 38QRR018 / 40QAQ024*

Temp °F (°C) Air Entering Condenser (Edb)		Air Entering Evaporator – Cfm/BF											
		320/0.02				400/0.03				500/0.03			
		Air Entering Evaporator – Ewb °F (°C)											
		57 (13.9)	62 (16.7)	67 (19.4)	72 (22.2)	57 (13.9)	62 (16.7)	67 (19.4)	72 (22.2)	57 (13.9)	62 (16.7)	67 (19.4)	72 (22.2)
55 (12.8)	TCG	15.3	16.7	17.8	18.6	16.1	17.4	18.3	18.9	16.9	17.8	18.6	19.2
	SHG	14.2	12.9	11.2	9.4	16.1	14.2	11.9	9.7	16.9	15.1	12.3	9.9
	TC	15.0	16.4	17.5	18.3	15.8	17.1	18.0	18.7	16.6	17.5	18.3	18.9
	kW	0.91	0.91	0.91	0.92	0.91	0.91	0.91	0.92	0.91	0.91	0.92	0.92
	CMP	0.72	0.73	0.73	0.73	0.72	0.73	0.73	0.73	0.72	0.73	0.73	0.73
	LDB	40.0	44.0	49.2	54.7	43.8	48.4	54.0	59.2	48.3	51.9	57.4	62.2
65 (18.3)	LWB	37.1	42.4	48.2	54.7	40.7	46.1	52.1	58.4	43.0	48.8	54.7	60.8
	TCG	14.6	16.2	17.6	18.7	15.4	17.0	18.3	19.1	16.5	17.6	18.6	19.4
	SHG	13.8	12.6	11.2	9.4	15.4	14.1	12.0	9.8	16.5	15.3	12.7	10.1
	TC	14.4	15.9	17.4	18.4	15.2	16.8	18.0	18.9	16.3	17.3	18.4	19.1
	kW	1.02	1.02	1.03	1.03	1.02	1.02	1.03	1.03	1.02	1.03	1.03	1.03
	CMP	0.83	0.84	0.84	0.84	0.84	0.84	0.84	0.85	0.84	0.84	0.84	0.85
75 (23.9)	LDB	41.2	45.1	49.4	54.7	45.2	48.5	53.6	59.0	48.9	51.5	56.8	62.0
	LWB	38.1	43.1	48.5	54.6	41.5	46.5	52.2	58.3	43.4	49.0	54.7	60.7
	TCG	14.0	15.5	17.1	18.5	14.9	16.3	17.9	19.1	15.9	16.9	18.4	19.4
	SHG	13.4	12.1	10.8	9.3	14.9	13.7	11.9	9.8	15.9	15.1	12.8	10.2
	TC	13.7	15.2	16.8	18.2	14.6	16.1	17.6	18.8	15.6	16.7	18.1	19.1
	kW	1.14	1.15	1.15	1.16	1.15	1.15	1.15	1.16	1.15	1.15	1.16	1.16
85 (29.4)	CMP	0.95	0.97	0.97	0.97	0.96	0.97	0.97	0.97	0.97	0.97	0.97	0.98
	LDB	42.3	46.4	50.3	55.0	46.5	49.5	53.8	59.0	50.1	51.9	56.6	61.8
	LWB	39.2	44.1	49.2	54.8	42.2	47.2	52.5	58.3	44.0	49.5	54.9	60.7
	TCG	13.3	14.7	16.3	18.0	14.3	15.5	17.2	18.7	15.2	16.0	17.7	19.1
	SHG	13.0	11.7	10.4	9.1	14.3	13.2	11.6	9.7	15.2	14.6	12.6	10.2
	TC	13.0	14.5	16.1	17.7	14.0	15.2	16.9	18.4	15.0	15.8	17.5	18.8
95 (35)	kW	1.26	1.28	1.29	1.30	1.27	1.29	1.30	1.30	1.29	1.29	1.30	1.30
	CMP	1.08	1.10	1.11	1.11	1.09	1.11	1.11	1.11	1.10	1.11	1.11	1.12
	LDB	43.6	47.5	51.6	55.7	47.9	50.7	54.5	59.2	51.4	52.9	56.9	61.8
	LWB	40.2	45.1	50.1	55.4	42.8	48.1	53.2	58.6	44.6	50.3	55.4	60.9
	TCG	12.5	13.9	15.4	17.2	13.6	14.6	16.2	17.9	14.5	15.1	17.2	18.4
	SHG	12.5	11.3	10.0	8.7	13.6	12.7	11.1	9.4	14.5	14.0	12.5	10.0
105 (40.6)	TC	12.2	13.6	15.2	16.9	13.4	14.4	16.0	17.7	14.3	14.9	17.0	18.1
	kW	1.40	1.42	1.44	1.45	1.41	1.43	1.45	1.46	1.43	1.44	1.45	1.46
	CMP	1.21	1.23	1.26	1.27	1.23	1.25	1.27	1.27	1.24	1.25	1.27	1.27
	LDB	44.9	48.6	52.8	56.8	49.4	51.8	55.6	59.8	52.8	53.9	57.6	62.1
	LWB	41.4	46.2	51.2	56.3	43.6	49.0	54.1	59.2	45.2	51.0	56.0	61.3
	TCG	11.8	13.0	14.5	16.2	12.9	13.7	15.2	17.0	13.8	14.1	15.7	17.5
115 (46.1)	SHG	11.8	10.9	9.5	8.2	12.9	12.2	10.6	9.0	13.8	13.5	11.7	9.7
	TC	11.6	12.7	14.2	15.9	12.7	13.4	15.0	16.7	13.5	13.9	15.4	17.2
	kW	1.55	1.57	1.60	1.62	1.56	1.58	1.61	1.63	1.58	1.59	1.62	1.63
	CMP	1.36	1.38	1.41	1.44	1.38	1.39	1.43	1.44	1.39	1.40	1.43	1.44
	LDB	46.9	49.9	54.1	58.2	51.0	52.8	56.7	60.7	54.2	54.9	58.6	62.7
	LWB	42.3	47.4	52.3	57.4	44.4	50.0	55.0	60.0	45.9	51.8	56.9	61.9
125 (51.7)	TCG	11.1	12.0	13.5	15.1	12.1	12.6	14.1	15.8	12.9	13.0	14.5	16.3
	SHG	11.1	10.4	9.1	7.7	12.1	11.7	10.1	8.5	12.9	13.0	11.1	9.2
	TC	10.8	11.7	13.2	14.8	11.9	12.3	13.8	15.5	12.7	12.7	14.3	16.0
	kW	1.71	1.72	1.76	1.80	1.73	1.74	1.77	1.81	1.74	1.75	1.79	1.81
	CMP	1.52	1.54	1.57	1.61	1.54	1.55	1.59	1.63	1.56	1.56	1.60	1.63
	LDB	49.0	51.2	55.3	59.5	52.8	53.9	57.9	61.9	55.8	55.8	59.6	63.5
125 (51.7)	LWB	43.4	48.7	53.6	58.5	45.3	51.0	56.0	61.0	46.7	52.7	57.7	62.7
	TCG	10.3	10.8	12.3	13.9	11.2	11.4	12.9	14.5	12.0	12.0	13.2	14.9
	SHG	10.3	9.9	8.6	7.2	11.2	11.1	9.6	8.0	12.0	12.0	10.6	8.6
	TC	10.0	10.6	12.1	13.6	11.0	11.2	12.6	14.2	11.7	11.7	13.0	14.6
	kW	1.89	1.90	1.93	1.98	1.90	1.91	1.95	2.00	1.92	1.92	1.96	2.01
	CMP	1.70	1.71	1.75	1.79	1.72	1.72	1.76	1.81	1.74	1.74	1.77	1.82
125 (51.7)	LDB	51.3	52.7	56.7	60.8	54.9	55.2	59.0	63.0	57.6	57.7	60.6	64.5
	LWB	44.6	50.2	54.9	59.8	46.3	52.2	57.1	62.0	47.5	53.5	58.6	63.6

Rating Condition.
Not recommended for long-term operation

- BF – Bypass Factor
- CMP – Compressor
- Edb – Entering Dry Bulb
- Ewb – Entering Wet Bulb
- kW – Total Power
- LDB – Leaving Dry Bulb
- LWB – Leaving Wet Bulb
- SHG – Gross Sensible Capacity (1000 Btuh)
- TC – Total Net Cooling Capacity (1000 Btuh)
- TCG – Gross Cooling Capacity (1000 Btuh)

* The 40QAQ024 unit must be field configured to an 018 size unit by changing the motor speed fan tap plug. Refer to Installation Instructions for more details.

NOTES:

1. Direct interpolation is permissible. Do not extrapolate.
2. The SHG is based on 80°F (26.7°C) edb temperature of air entering indoor coil.

Below 80°F (26.7°C) edb, subtract (corr factor x cfm) from SHG.

Above 80°F (26.7°C) edb, add (corr factor x cfm) to SHG.

Correction Factor = 1.10 x (1 - BF) x (edb - 80).

PERFORMANCE DATA (CONT.)

COOLING CAPACITIES 38QRR024 / 40QAQ024

Temp °F (°C) Air Entering Condenser (Edb)		Air Entering Evaporator – Cfm/BF											
		400/0.03				500/0.03				600/0.04			
		Air Entering Evaporator – Ewb °F (°C)											
		57 (13.9)	62 (16.7)	67 (19.4)	72 (22.2)	57 (13.9)	62 (16.7)	67 (19.4)	72 (22.2)	57 (13.9)	62 (16.7)	67 (19.4)	72 (22.2)
55 (12.8)	TCG	20.5	22.4	24.1	25.3	21.5	23.4	24.7	25.3	21.7	23.9	25.1	26.0
	SHG	18.7	17.0	15.0	12.7	20.6	18.5	15.8	13.1	21.0	19.5	16.3	13.4
	TC	20.2	22.1	23.8	25.0	21.2	23.1	24.4	25.0	21.4	23.6	24.8	25.6
	kW	1.18	1.18	1.19	1.20	1.18	1.19	1.19	1.19	1.18	1.19	1.20	1.20
	CMP	0.99	1.00	1.00	1.01	0.99	1.00	1.01	1.00	0.99	1.00	1.01	1.01
	LDB	38.0	42.2	47.0	52.8	41.4	45.6	51.1	56.6	42.1	48.3	54.0	59.1
65 (18.3)	LWB	35.3	40.5	46.3	52.8	38.5	43.8	49.9	56.5	39.2	46.1	52.1	58.4
	TCG	19.7	21.7	23.7	25.3	20.7	22.8	24.6	25.8	21.0	23.4	25.1	26.1
	SHG	18.1	16.5	14.8	12.7	19.9	18.1	15.8	13.1	20.4	19.4	16.5	13.4
	TC	19.4	21.4	23.4	25.0	20.4	22.4	24.3	25.5	20.6	23.1	24.7	25.8
	kW	1.32	1.34	1.35	1.35	1.33	1.34	1.35	1.36	1.33	1.34	1.35	1.36
	CMP	1.13	1.15	1.16	1.17	1.15	1.16	1.16	1.17	1.15	1.16	1.17	1.18
75 (23.9)	LDB	39.2	43.3	47.6	52.8	42.6	46.3	51.1	56.5	43.3	48.5	53.7	59.0
	LWB	36.4	41.3	46.7	52.8	39.3	44.4	50.0	56.2	39.9	46.5	52.2	58.3
	TCG	18.9	20.8	23.0	24.9	19.8	21.9	24.0	25.7	19.9	22.6	24.6	26.1
	SHG	17.7	16.0	14.3	12.5	19.3	17.5	15.5	13.1	19.9	18.9	16.4	13.4
	TC	18.5	20.5	22.7	24.6	19.5	21.5	23.7	25.4	19.6	22.2	24.3	25.7
	kW	1.47	1.50	1.52	1.53	1.49	1.51	1.52	1.53	1.49	1.52	1.53	1.54
85 (29.4)	CMP	1.29	1.32	1.33	1.34	1.30	1.33	1.34	1.35	1.30	1.33	1.34	1.35
	LDB	40.3	44.5	48.6	53.2	43.7	47.5	51.6	56.6	44.0	49.3	53.8	59.0
	LWB	37.4	42.4	47.5	53.1	40.2	45.2	50.5	56.3	40.9	47.2	52.5	58.4
	TCG	18.0	19.9	22.0	24.2	18.8	20.8	23.1	25.1	19.1	21.5	23.7	25.6
	SHG	17.1	15.5	13.8	12.1	18.8	17.0	15.0	12.8	19.1	18.2	16.0	13.3
	TC	17.6	19.6	21.7	23.9	18.5	20.5	22.7	24.8	18.8	21.1	23.4	25.3
95 (35)	kW	1.64	1.68	1.71	1.72	1.66	1.69	1.71	1.73	1.66	1.70	1.72	1.73
	CMP	1.46	1.49	1.52	1.53	1.47	1.51	1.53	1.54	1.48	1.52	1.53	1.54
	LDB	41.5	45.7	49.9	54.0	44.7	48.5	52.5	57.0	45.6	50.4	54.4	59.2
	LWB	38.5	43.5	48.5	53.8	41.2	46.2	51.3	56.7	41.7	48.0	53.1	58.6
	TCG	17.0	18.8	20.9	23.2	18.0	19.7	21.9	24.1	18.3	20.3	23.3	24.7
	SHG	16.6	14.9	13.2	11.6	18.0	16.4	14.4	12.4	18.3	17.6	16.0	13.0
105 (40.6)	TC	16.7	18.5	20.6	22.9	17.7	19.4	21.6	23.8	17.9	20.0	23.0	24.4
	kW	1.92	1.96	2.00	2.03	1.94	1.98	2.02	2.03	1.95	1.99	2.02	2.04
	CMP	1.74	1.78	1.82	1.84	1.76	1.79	1.83	1.85	1.76	1.81	1.84	1.85
	LDB	42.8	46.8	51.1	55.2	46.3	49.6	53.7	57.8	47.1	51.4	55.3	59.7
	LWB	39.7	44.6	49.6	54.7	42.0	47.2	52.2	57.4	42.5	48.9	53.9	59.2
	TCG	15.9	17.7	19.7	22.0	17.1	18.5	20.6	22.9	17.4	19.0	21.2	23.5
115 (46.1)	SHG	15.9	14.4	12.7	11.0	17.1	15.8	13.8	11.9	17.4	17.0	14.8	12.5
	TC	15.6	17.4	19.4	21.7	16.8	18.2	20.3	22.6	17.0	18.7	20.8	23.2
	kW	2.01	2.06	2.11	2.15	2.04	2.08	2.13	2.16	2.05	2.09	2.14	2.16
	CMP	1.83	1.87	1.92	1.96	1.86	1.89	1.94	1.97	1.86	1.91	1.96	1.98
	LDB	44.3	48.1	52.4	56.4	48.0	50.7	54.8	58.8	48.7	52.5	56.4	60.5
	LWB	41.0	45.8	50.8	55.8	42.9	48.2	53.2	58.3	43.3	49.8	54.8	59.9
125 (51.7)	TCG	15.0	16.5	18.4	20.6	16.1	17.2	19.2	21.5	16.4	17.7	19.7	22.1
	SHG	15.0	13.8	12.1	10.4	16.1	15.2	13.2	11.3	16.4	16.3	14.1	11.9
	TC	14.6	16.1	18.1	20.2	15.8	16.9	18.9	21.2	16.0	17.4	19.4	21.7
	kW	2.23	2.27	2.32	2.38	2.26	2.29	2.35	2.40	2.26	2.30	2.36	2.40
	CMP	2.04	2.08	2.14	2.20	2.07	2.10	2.16	2.21	2.08	2.12	2.18	2.21
	LDB	46.4	49.5	53.7	57.9	49.8	51.9	56.0	59.9	50.6	53.5	57.4	61.4
125 (51.7)	LWB	42.1	47.2	52.1	57.1	43.8	49.3	54.3	59.3	44.2	50.8	55.8	60.8
	TCG	14.0	15.1	17.0	19.1	15.0	15.7	17.7	19.8	15.3	16.2	18.1	20.4
	SHG	14.0	13.1	11.4	9.8	15.0	14.5	12.5	10.6	15.3	15.6	13.4	11.2
	TC	13.6	14.7	16.7	18.7	14.7	15.4	17.3	19.5	14.9	15.9	17.8	20.0
	kW	2.45	2.49	2.55	2.62	2.49	2.51	2.58	2.65	2.49	2.53	2.59	2.65
	CMP	2.27	2.30	2.36	2.44	2.30	2.32	2.39	2.46	2.31	2.34	2.41	2.47
125 (51.7)	LDB	48.8	50.9	55.1	59.2	51.9	53.2	57.2	61.2	52.6	54.8	58.6	62.5
	LWB	43.3	48.6	53.4	58.4	44.8	50.6	55.4	60.4	45.2	51.8	56.8	61.7

Rating Condition.
Not recommended for long-term operation

- BF – Bypass Factor
- CMP – Compressor
- Edb – Entering Dry Bulb
- Ewb – Entering Wet Bulb
- kW – Total Power
- LDB – Leaving Dry Bulb
- LWB – Leaving Wet Bulb
- SHG – Gross Sensible Capacity (1000 Btuh)
- TC – Total Net Cooling Capacity (1000 Btuh)
- TCG – Gross Cooling Capacity (1000 Btuh)

NOTES:

1. Direct interpolation is permissible. Do not extrapolate.
2. The SHG is based on 80°F (26.7°C) edb temperature of air entering indoor coil.

Below 80°F (26.7°C) edb, subtract (corr factor x cfm) from SHG.
Above 80°F (26.7°C) edb, add (corr factor x cfm) to SHG.
Correction Factor = 1.10 x (1 – BF) x (edb – 80).

40QAC/38HDR – 40QAQ/38QRF

PERFORMANCE DATA (CONT.)

COOLING CAPACITIES 38QRR030 / 40QAQ036

Temp °F (°C) Air Entering Condenser (Edb)		Air Entering Evaporator – Cfm/BF											
		640/0.02				740/0.02				840/0.03			
		Air Entering Evaporator – Ewb °F (°C)											
		57 (13.9)	62 (16.7)	67 (19.4)	72 (22.2)	57 (13.9)	62 (16.7)	67 (19.4)	72 (22.2)	57 (13.9)	62 (16.7)	67 (19.4)	72 (22.2)
55 (12.8)	TCG	26.4	29.0	31.1	32.5	28.0	29.9	31.7	32.9	29.3	30.5	32.1	33.1
	SHG	26.4	23.7	20.4	16.7	28.0	25.8	21.5	17.2	29.3	27.4	22.3	17.5
	TC	25.7	28.2	30.4	31.8	27.3	29.2	31.0	32.1	28.6	29.8	31.3	32.4
	kW	1.59	1.59	1.59	1.59	1.59	1.59	1.59	1.59	1.59	1.59	1.59	1.59
	CMP	1.24	1.24	1.24	1.24	1.24	1.24	1.24	1.24	1.24	1.24	1.24	1.24
	LDB	42.7	46.9	52.0	57.7	46.7	49.7	55.2	60.7	49.9	52.2	57.8	63.0
65 (18.3)	LWB	40.2	45.3	50.9	57.1	42.2	47.8	53.6	59.7	43.8	49.7	55.5	61.5
	TCG	25.4	28.0	30.6	32.6	27.1	29.0	31.4	33.1	28.5	29.7	32.0	33.4
	SHG	25.4	23.1	20.3	16.8	27.1	25.3	21.7	17.4	28.5	27.2	22.8	17.9
	TC	24.7	27.2	29.8	31.8	26.4	28.2	30.7	32.3	27.8	29.0	31.2	32.6
	kW	1.75	1.75	1.75	1.75	1.75	1.75	1.75	1.75	1.75	1.75	1.75	1.75
	CMP	1.40	1.40	1.40	1.40	1.40	1.40	1.40	1.40	1.40	1.40	1.40	1.40
75 (23.9)	LDB	44.1	47.8	52.2	57.5	47.7	50.2	55.0	60.4	50.7	52.3	57.2	62.6
	LWB	40.9	46.0	51.3	57.1	42.8	48.3	53.7	59.6	44.3	50.1	55.5	61.4
	TCG	24.5	26.8	29.5	32.0	26.1	27.7	30.4	32.7	27.5	28.5	31.1	33.1
	SHG	24.5	22.4	19.7	16.6	26.1	24.6	21.3	17.4	27.5	26.6	22.7	18.0
	TC	23.8	26.0	28.7	31.2	25.4	27.0	29.7	31.9	26.7	27.7	30.4	32.4
	kW	1.92	1.93	1.93	1.93	1.93	1.93	1.93	1.93	1.93	1.93	1.93	1.93
85 (29.4)	CMP	1.57	1.58	1.58	1.58	1.58	1.58	1.58	1.58	1.58	1.58	1.58	1.58
	LDB	45.4	48.8	53.0	57.8	49.0	51.1	55.4	60.5	51.8	52.9	57.3	62.5
	LWB	41.6	46.8	51.9	57.4	43.4	49.0	54.2	59.8	44.8	50.7	55.9	61.5
	TCG	23.5	25.4	28.2	30.9	25.1	26.3	29.1	31.7	26.3	27.0	29.8	32.3
	SHG	23.5	21.7	19.0	16.2	25.1	23.8	20.7	17.1	26.3	25.7	22.3	17.9
	TC	22.8	24.7	27.4	30.2	24.3	25.6	28.4	31.0	25.6	26.3	29.1	31.5
95 (35)	kW	2.11	2.12	2.13	2.13	2.12	2.12	2.13	2.13	2.12	2.13	2.13	2.13
	CMP	1.76	1.77	1.78	1.78	1.77	1.77	1.78	1.78	1.77	1.78	1.78	1.78
	LDB	46.8	49.7	53.9	58.4	50.3	52.0	56.1	60.8	53.1	53.9	57.8	62.6
	LWB	42.3	47.7	52.7	58.0	44.0	49.8	54.8	60.2	45.4	51.3	56.4	61.8
	TCG	22.4	23.9	26.6	29.5	23.9	24.8	27.5	30.4	25.1	25.5	28.7	31.0
	SHG	22.4	21.0	18.3	15.6	23.9	23.0	19.9	16.6	25.1	24.9	22.0	17.5
105 (40.6)	TC	21.7	23.2	25.8	28.8	23.1	24.0	26.7	29.7	24.3	24.7	28.0	30.3
	kW	2.46	2.47	2.49	2.50	2.47	2.48	2.50	2.50	2.48	2.48	2.50	2.51
	CMP	2.11	2.12	2.14	2.15	2.12	2.13	2.15	2.15	2.13	2.13	2.15	2.16
	LDB	48.5	50.8	55.0	59.3	51.7	52.9	57.1	61.3	54.4	54.7	58.5	63.0
	LWB	43.1	48.7	53.7	58.8	44.8	50.6	55.6	60.8	46.0	52.0	57.1	62.2
	TCG	21.2	22.3	24.9	27.7	22.6	23.1	25.7	28.7	23.7	23.8	26.3	29.3
115 (46.1)	SHG	21.2	20.2	17.5	14.8	22.6	22.2	19.1	16.0	23.7	23.8	20.7	16.9
	TC	20.4	21.5	24.2	27.0	21.8	22.3	25.0	27.9	23.0	23.0	25.5	28.6
	kW	2.53	2.54	2.57	2.60	2.54	2.55	2.57	2.60	2.55	2.55	2.58	2.60
	CMP	2.18	2.19	2.22	2.25	2.19	2.20	2.22	2.25	2.20	2.20	2.23	2.25
	LDB	50.3	51.9	56.1	60.4	53.3	54.0	57.9	62.1	55.8	55.9	59.4	63.5
	LWB	44.0	49.7	54.6	59.7	45.5	51.5	56.5	61.5	46.7	52.7	57.8	62.9
125 (51.7)	TCG	19.8	20.4	23.0	25.8	21.1	21.2	23.7	26.5	22.2	22.2	24.2	27.1
	SHG	19.8	19.4	16.7	14.0	21.1	21.2	18.3	15.1	22.2	22.2	19.8	16.1
	TC	19.1	19.7	22.2	25.0	20.4	20.4	23.0	25.8	21.4	21.5	23.5	26.4
	kW	2.75	2.77	2.80	2.84	2.78	2.78	2.81	2.85	2.79	2.79	2.82	2.86
	CMP	2.40	2.42	2.45	2.49	2.43	2.43	2.46	2.50	2.44	2.44	2.47	2.51
	LDB	52.3	53.1	57.2	61.4	55.1	55.1	59.0	63.1	57.4	57.5	60.3	64.4
125 (51.7)	LWB	45.0	50.9	55.7	60.7	46.4	52.4	57.4	62.4	47.4	53.4	58.6	63.6
	TCG	18.3	18.4	20.8	23.6	19.5	19.5	21.5	24.3	20.5	20.5	21.9	24.8
	SHG	18.3	18.4	15.8	13.2	19.5	19.5	17.3	14.2	20.5	20.5	18.8	15.2
	TC	17.6	17.6	20.1	22.9	18.8	18.8	20.7	23.5	19.7	19.8	21.2	24.0
	kW	3.01	3.01	3.06	3.10	3.03	3.03	3.07	3.11	3.05	3.05	3.08	3.12
	CMP	2.66	2.66	2.71	2.75	2.68	2.68	2.72	2.76	2.70	2.70	2.73	2.77
125 (51.7)	LDB	54.4	54.5	58.4	62.6	57.1	57.2	60.0	64.1	59.2	59.3	61.3	65.3
	LWB	46.1	52.2	56.9	61.8	47.3	53.3	58.4	63.3	48.3	54.2	59.5	64.4

Rating Condition.
Not recommended for long-term operation

- BF – Bypass Factor
- CMP – Compressor
- Edb – Entering Dry Bulb
- Ewb – Entering Wet Bulb
- kW – Total Power
- LDB – Leaving Dry Bulb
- LWB – Leaving Wet Bulb
- SHG – Gross Sensible Capacity (1000 Btuh)
- TC – Total Net Cooling Capacity (1000 Btuh)
- TCG – Gross Cooling Capacity (1000 Btuh)

NOTES:

1. Direct interpolation is permissible. Do not extrapolate.
2. The SHG is based on 80°F (26.7°C) edb temperature of air entering indoor coil.

Below 80°F (26.7°C) edb, subtract (corr factor x cfm) from SHG.
Above 80°F (26.7°C) edb, add (corr factor x cfm) to SHG.
Correction Factor = 1.10 x (1 – BF) x (edb – 80).

PERFORMANCE DATA (CONT.)

COOLING CAPACITIES 38QRR036 / 40QAQ036

Temp °F (°C) Air Entering Condenser (Edb)		Air Entering Evaporator – Cfm/BF											
		640/0.02				740/0.02				840/0.03			
		Air Entering Evaporator – Ewb °F (°C)											
		57 (13.9)	62 (16.7)	67 (19.4)	72 (22.2)	57 (13.9)	62 (16.7)	67 (19.4)	72 (22.2)	57 (13.9)	62 (16.7)	67 (19.4)	72 (22.2)
55 (12.8)	TCG	29.9	32.6	34.8	36.0	31.0	33.7	35.4	36.4	32.3	34.4	35.8	36.6
	SHG	27.9	25.4	22.1	18.4	30.9	27.3	23.0	18.8	32.3	28.8	23.7	19.1
	TC	29.2	31.8	34.0	35.3	30.3	33.0	34.7	35.7	31.5	33.7	35.0	35.9
	kW	1.70	1.70	1.70	1.71	1.70	1.70	1.71	1.71	1.70	1.70	1.71	1.71
	CMP	1.35	1.35	1.35	1.36	1.35	1.35	1.36	1.36	1.35	1.35	1.36	1.36
	LDB	40.5	44.5	49.6	55.3	43.2	47.8	53.4	58.8	46.8	50.7	56.4	61.4
65 (18.3)	LWB	37.5	42.7	48.6	55.2	40.4	45.7	51.7	58.1	42.3	47.9	54.0	60.2
	TCG	28.9	31.7	34.4	36.4	30.0	32.9	35.3	36.9	31.4	33.8	35.9	37.3
	SHG	27.2	24.8	21.9	18.5	30.0	27.0	23.2	19.1	31.4	28.9	24.2	19.5
	TC	28.1	30.9	33.6	35.6	29.2	32.2	34.6	36.2	30.7	33.1	35.2	36.6
	kW	1.90	1.91	1.91	1.91	1.91	1.91	1.91	1.91	1.91	1.91	1.91	1.92
	CMP	1.55	1.56	1.56	1.56	1.56	1.56	1.56	1.56	1.56	1.56	1.56	1.57
75 (23.9)	LDB	41.5	45.4	49.9	55.1	44.3	48.2	53.1	58.5	47.7	50.6	55.8	61.0
	LWB	38.3	43.4	48.9	55.0	41.0	46.1	51.7	57.9	42.7	48.2	53.9	60.0
	TCG	27.7	30.5	33.5	36.0	28.9	31.8	34.6	36.7	30.4	32.7	35.4	37.1
	SHG	26.5	24.0	21.4	18.3	28.9	26.3	23.0	19.0	30.4	28.4	24.2	19.5
	TC	27.0	29.8	32.7	35.2	28.1	31.0	33.9	35.9	29.6	31.9	34.6	36.4
	kW	2.10	2.14	2.14	2.14	2.12	2.14	2.14	2.15	2.14	2.14	2.14	2.15
85 (29.4)	CMP	1.75	1.79	1.79	1.79	1.77	1.79	1.79	1.80	1.79	1.79	1.79	1.80
	LDB	42.6	46.5	50.6	55.4	45.6	49.0	53.4	58.6	48.8	51.1	55.8	61.0
	LWB	39.2	44.2	49.4	55.2	41.7	46.8	52.1	58.0	43.3	48.7	54.1	60.0
	TCG	26.4	29.2	32.3	35.2	27.8	30.4	33.4	36.1	29.2	31.2	34.3	36.7
	SHG	25.7	23.2	20.7	17.9	27.8	25.4	22.5	18.8	29.2	27.5	23.9	19.5
	TC	25.7	28.5	31.5	34.4	27.0	29.6	32.7	35.4	28.5	30.5	33.6	36.0
95 (35)	kW	2.33	2.36	2.39	2.40	2.34	2.38	2.40	2.40	2.37	2.39	2.40	2.40
	CMP	1.98	2.01	2.04	2.05	1.99	2.03	2.05	2.05	2.02	2.04	2.05	2.05
	LDB	43.7	47.6	51.6	55.9	47.0	50.1	54.0	58.8	50.0	52.1	56.1	61.0
	LWB	40.2	45.1	50.2	55.7	42.4	47.6	52.7	58.2	43.9	49.4	54.5	60.2
	TCG	24.9	27.7	30.7	33.9	26.6	28.8	31.9	35.0	28.0	29.6	33.7	35.8
	SHG	24.9	22.5	19.9	17.3	26.6	24.5	21.6	18.4	28.0	26.5	23.9	19.2
105 (40.6)	TC	24.2	27.0	30.0	33.2	25.9	28.0	31.1	34.3	27.3	28.9	33.0	35.1
	kW	2.73	2.77	2.82	2.84	2.75	2.79	2.84	2.84	2.78	2.80	2.84	2.85
	CMP	2.38	2.42	2.47	2.49	2.40	2.44	2.49	2.49	2.43	2.45	2.49	2.50
	LDB	44.9	48.7	52.8	56.8	48.4	51.2	55.1	59.3	51.3	53.1	56.8	61.3
	LWB	41.3	46.1	51.2	56.4	43.1	48.4	53.5	58.7	44.5	50.1	55.2	60.5
	TCG	23.7	26.0	29.0	32.2	25.3	27.1	30.1	33.4	26.6	27.8	30.9	34.3
115 (46.1)	SHG	23.7	21.6	19.0	16.5	25.3	23.6	20.6	17.7	26.6	25.5	22.3	18.7
	TC	22.9	25.3	28.2	31.5	24.5	26.3	29.3	32.7	25.9	27.1	30.1	33.5
	kW	2.84	2.88	2.93	2.99	2.86	2.90	2.96	3.00	2.89	2.91	2.97	3.00
	CMP	2.49	2.53	2.58	2.64	2.51	2.55	2.61	2.65	2.54	2.56	2.62	2.65
	LDB	46.7	49.9	54.0	58.0	50.0	52.2	56.2	60.1	52.7	54.1	57.7	61.8
	LWB	42.2	47.3	52.2	57.3	43.9	49.4	54.4	59.5	45.2	50.9	56.0	61.1
125 (51.7)	TCG	22.3	24.1	27.1	30.2	23.8	25.1	28.1	31.3	25.1	25.9	28.8	32.2
	SHG	22.3	20.7	18.2	15.6	23.8	22.7	19.7	16.8	25.1	24.5	21.2	17.9
	TC	21.5	23.4	26.4	29.5	23.1	24.4	27.3	30.6	24.4	25.1	28.0	31.4
	kW	3.14	3.17	3.23	3.30	3.16	3.19	3.25	3.33	3.19	3.20	3.27	3.34
	CMP	2.79	2.82	2.88	2.95	2.81	2.84	2.90	2.98	2.84	2.85	2.92	2.99
	LDB	48.7	51.2	55.2	59.2	51.8	53.4	57.3	61.2	54.3	55.1	58.8	62.6
125 (51.7)	LWB	43.2	48.5	53.4	58.4	44.8	50.4	55.3	60.4	46.0	51.8	56.8	61.8
	TCG	20.7	22.0	24.9	28.0	22.2	22.9	25.8	28.9	23.4	23.6	26.5	29.7
	SHG	20.7	19.8	17.2	14.6	22.2	21.7	18.8	15.8	23.4	23.6	20.2	16.9
	TC	20.0	21.3	24.2	27.2	21.4	22.2	25.1	28.2	22.7	22.8	25.7	28.9
	kW	3.47	3.49	3.55	3.63	3.49	3.50	3.57	3.66	3.52	3.52	3.59	3.68
	CMP	3.12	3.14	3.20	3.28	3.14	3.15	3.22	3.31	3.17	3.17	3.24	3.33
125 (51.7)	LDB	50.9	52.5	56.5	60.6	53.8	54.6	58.4	62.3	56.1	56.1	59.8	63.6
	LWB	44.4	49.9	54.6	59.6	45.7	51.6	56.4	61.4	46.8	52.8	57.7	62.7

Rating Condition.
Not recommended for long-term operation

- BF – Bypass Factor
- CMP – Compressor
- Edb – Entering Dry Bulb
- Ewb – Entering Wet Bulb
- kW – Total Power
- LDB – Leaving Dry Bulb
- LWB – Leaving Wet Bulb
- SHG – Gross Sensible Capacity (1000 Btuh)
- TC – Total Net Cooling Capacity (1000 Btuh)
- TCG – Gross Cooling Capacity (1000 Btuh)

- NOTES:
- Direct interpolation is permissible. Do not extrapolate.
 - The SHG is based on 80°F (26.7°C) edb temperature of air entering indoor coil.

Below 80°F (26.7°C) edb, subtract (corr factor x cfm) from SHG.
Above 80°F (26.7°C) edb, add (corr factor x cfm) to SHG.
Correction Factor = 1.10 x (1 – BF) x (edb – 80).

40QAC/38HDR – 40QAQ/38QRF

PERFORMANCE DATA (CONT.)

COOLING CAPACITIES 38QRR048 / 40QAQ048

Temp °F (°C) Air Entering Condenser (Edb)		Air Entering Evaporator – Cfm/BF											
		1100/0.05				1160/0.05				1200/0.06			
		Air Entering Evaporator – Ewb °F (°C)											
		57 (13.9)	62 (16.7)	67 (19.4)	72 (22.2)	57 (13.9)	62 (16.7)	67 (19.4)	72 (22.2)	57 (13.9)	62 (16.7)	67 (19.4)	72 (22.2)
55 (12.8)	TCG	43.5	45.4	47.0	48.4	44.2	46.3	47.8	49.2	45.0	46.8	48.3	49.7
	SHG	40.9	35.0	29.8	24.8	43.9	36.7	30.8	25.8	45.0	38.0	31.6	26.2
	TC	42.4	44.3	45.8	47.3	43.1	45.1	46.6	48.0	43.9	45.7	47.2	48.5
	kW	2.44	2.44	2.44	2.44	2.43	2.44	2.44	2.44	2.43	2.44	2.44	2.43
	CMP	2.09	2.09	2.09	2.09	2.08	2.09	2.09	2.09	2.08	2.09	2.09	2.08
	LDB	35.6	42.5	48.7	54.6	39.8	46.9	52.7	57.7	43.4	49.6	55.2	59.9
65 (18.3)	LWB	34.7	41.1	47.8	54.6	38.5	44.6	51.1	57.5	40.6	46.7	53.0	59.3
	TCG	42.4	45.1	47.0	48.8	44.0	46.1	48.0	49.8	45.1	46.8	48.6	50.3
	SHG	40.4	35.1	30.0	25.0	44.0	37.2	31.3	26.1	45.1	38.7	32.2	26.6
	TC	41.3	44.0	45.9	47.7	42.9	45.0	46.8	48.6	43.9	45.7	47.5	49.2
	kW	2.76	2.76	2.76	2.76	2.76	2.76	2.76	2.76	2.75	2.76	2.76	2.76
	CMP	2.41	2.41	2.41	2.41	2.41	2.41	2.41	2.41	2.40	2.41	2.41	2.41
75 (23.9)	LDB	36.2	42.4	48.5	54.4	39.7	46.4	52.3	57.4	43.4	49.0	54.7	59.6
	LWB	35.4	41.3	47.8	54.4	38.6	44.7	51.0	57.3	40.6	46.7	52.9	59.1
	TCG	40.7	44.6	46.6	48.6	43.2	45.7	47.6	49.4	44.6	46.4	48.2	49.9
	SHG	39.2	35.2	30.1	24.9	43.2	37.5	31.3	26.1	44.6	39.2	32.3	26.5
	TC	39.5	43.5	45.5	47.5	42.1	44.6	46.5	48.2	43.4	45.2	47.1	48.8
	kW	3.09	3.11	3.11	3.11	3.11	3.11	3.11	3.11	3.11	3.11	3.11	3.11
85 (29.4)	CMP	2.74	2.76	2.76	2.76	2.76	2.76	2.76	2.76	2.76	2.76	2.76	2.76
	LDB	37.5	42.4	48.3	54.5	40.4	46.2	52.2	57.5	43.8	48.5	54.6	59.7
	LWB	36.5	41.6	48.0	54.5	39.0	44.9	51.1	57.5	40.8	46.9	53.0	59.2
	TCG	38.7	42.8	46.3	48.1	41.3	44.9	47.3	49.0	43.6	45.7	47.7	49.5
	SHG	38.1	34.3	29.7	24.7	41.3	37.6	31.4	25.9	43.6	39.5	32.7	26.3
	TC	37.6	41.7	45.2	47.0	40.1	43.7	46.1	47.8	42.4	44.5	46.5	48.3
95 (35)	kW	3.43	3.48	3.50	3.50	3.48	3.49	3.50	3.51	3.50	3.49	3.50	3.50
	CMP	3.08	3.13	3.15	3.15	3.13	3.14	3.15	3.16	3.15	3.14	3.15	3.15
	LDB	38.7	43.2	48.8	54.7	42.3	46.0	52.1	57.6	44.7	48.3	54.3	59.8
	LWB	37.7	42.6	48.1	54.7	40.0	45.3	51.3	57.6	41.2	47.1	53.2	59.3
	TCG	36.8	40.6	45.1	47.5	39.4	42.4	46.5	48.3	41.4	43.9	46.1	48.9
	SHG	36.8	33.2	29.4	24.2	39.4	36.3	31.1	25.6	41.4	39.0	31.8	26.2
105 (40.6)	TC	35.6	39.5	44.0	46.4	38.2	41.3	45.3	47.1	40.3	42.8	45.0	47.7
	kW	3.80	3.86	3.89	3.92	3.86	3.89	3.89	3.92	3.89	3.90	3.90	3.93
	CMP	3.45	3.51	3.54	3.57	3.51	3.54	3.54	3.57	3.54	3.55	3.55	3.58
	LDB	40.2	44.5	49.1	55.3	44.1	47.2	52.4	57.8	46.4	48.7	54.5	59.9
	LWB	38.9	43.8	48.7	55.0	40.9	46.3	51.6	57.8	42.1	47.8	53.4	59.5
	TCG	34.7	38.3	42.7	46.4	37.4	40.0	44.6	47.3	39.3	41.1	45.6	47.8
115 (46.1)	SHG	34.7	32.0	28.2	23.6	37.4	35.1	30.7	24.9	39.3	37.5	32.2	25.8
	TC	33.6	37.1	41.6	45.2	36.2	38.8	43.5	46.1	38.1	39.9	44.5	46.6
	kW	4.23	4.26	4.35	4.37	4.28	4.30	4.37	4.38	4.31	4.32	4.37	4.38
	CMP	3.88	3.91	4.00	4.02	3.93	3.95	4.02	4.03	3.96	3.97	4.02	4.03
	LDB	42.4	45.8	50.4	55.8	45.9	48.3	52.8	58.6	48.2	49.9	54.6	60.2
	LWB	40.1	45.1	49.9	55.5	41.9	47.4	52.3	58.2	43.0	48.9	53.9	59.8
125 (51.7)	TCG	33.0	35.6	40.0	44.6	35.3	37.3	41.8	45.5	37.0	38.3	42.9	46.0
	SHG	33.0	30.8	27.0	23.1	35.3	33.8	29.3	24.1	37.0	36.1	31.2	25.0
	TC	31.8	34.5	38.8	43.4	34.2	36.1	40.7	44.3	35.8	37.2	41.7	44.9
	kW	4.65	4.69	4.78	4.85	4.72	4.73	4.83	4.85	4.76	4.75	4.85	4.86
	CMP	4.30	4.34	4.43	4.50	4.37	4.38	4.48	4.50	4.41	4.40	4.50	4.51
	LDB	44.4	47.2	51.7	56.4	47.9	49.5	54.0	59.2	50.1	51.0	55.4	60.9
125 (51.7)	LWB	41.1	46.5	51.2	56.2	42.8	48.6	53.4	58.8	44.0	49.9	54.8	60.4
	TCG	30.8	32.6	37.0	41.7	33.1	34.2	38.6	43.0	34.6	35.3	39.7	43.4
	SHG	30.8	29.3	25.7	21.9	33.1	32.4	28.0	23.2	34.6	34.6	29.8	24.1
	TC	29.6	31.4	35.9	40.5	31.9	33.1	37.5	41.8	33.4	34.1	38.5	42.3
	kW	5.13	5.16	5.25	5.36	5.19	5.19	5.30	5.36	5.24	5.22	5.33	5.37
	CMP	4.78	4.81	4.90	5.01	4.84	4.84	4.95	5.01	4.89	4.87	4.98	5.02
125 (51.7)	LDB	46.9	48.8	53.1	57.7	50.0	50.8	55.3	60.1	52.1	52.3	56.6	61.6
	LWB	42.3	48.0	52.6	57.5	43.9	49.8	54.6	59.7	44.9	51.0	55.8	61.1

Rating Condition.
Not recommended for long-term operation

- BF – Bypass Factor
- CMP – Compressor
- Edb – Entering Dry Bulb
- Ewb – Entering Wet Bulb
- kW – Total Power
- LDB – Leaving Dry Bulb
- LWB – Leaving Wet Bulb
- SHG – Gross Sensible Capacity (1000 Btuh)
- TC – Total Net Cooling Capacity (1000 Btuh)
- TCG – Gross Cooling Capacity (1000 Btuh)

NOTES:

1. Direct interpolation is permissible. Do not extrapolate.
2. The SHG is based on 80°F (26.7°C) edb temperature of air entering indoor coil.

Below 80°F (26.7°C) edb, subtract (corr factor x cfm) from SHG.
Above 80°F (26.7°C) edb, add (corr factor x cfm) to SHG.
Correction Factor = 1.10 x (1 - BF) x (edb - 80).

PERFORMANCE DATA (CONT.)

COOLING CAPACITIES 38QRR060 / 40QAQ060

Temp ° F (° C) Air Entering Condenser (Edb)	Air Entering Evaporator – Cfm/BF												
	1040/0.03				1220/0.04				1600/0.06				
	Air Entering Evaporator – Ewb ° F (° C)												
		57 (13.9)	62 (16.7)	67 (19.4)	72 (22.2)	57 (13.9)	62 (16.7)	67 (19.4)	72 (22.2)	57 (13.9)	62 (16.7)	67 (19.4)	72 (22.2)
55 (12.8)	TCG	51.5	56.2	61.5	67.3	54.5	59.2	64.6	70.6	60.6	63.8	69.4	75.5
	SHG	49.4	44.6	39.6	33.8	54.0	48.6	42.6	36.0	60.6	56.3	48.5	40.2
	TC	50.3	55.0	60.3	66.0	53.3	58.0	63.4	69.3	59.4	62.5	68.2	74.3
	kW	3.01	3.05	3.10	3.15	3.03	3.08	3.13	3.18	3.09	3.12	3.17	3.23
	CMP	2.66	2.70	2.75	2.80	2.68	2.73	2.78	2.83	2.74	2.77	2.82	2.88
	LDB	37.5	42.2	46.9	52.4	40.4	44.7	49.6	54.9	46.0	48.7	53.5	58.5
65 (18.3)	LWB	36.4	41.6	46.9	52.4	38.8	44.1	49.4	54.9	41.9	47.7	53.1	58.5
	TCG	49.7	54.2	59.2	64.8	52.5	56.9	62.1	67.8	58.5	61.2	66.5	72.4
	SHG	48.1	43.5	38.5	32.7	52.5	47.3	41.4	34.9	58.5	54.9	47.1	39.0
	TC	48.5	53.0	57.9	63.6	51.3	55.7	60.9	66.6	57.3	59.9	65.3	71.2
	kW	3.36	3.40	3.45	3.50	3.38	3.43	3.47	3.53	3.44	3.47	3.52	3.57
	CMP	3.01	3.05	3.10	3.15	3.03	3.08	3.12	3.18	3.09	3.12	3.17	3.22
75 (23.9)	LDB	38.7	43.1	47.8	53.3	41.4	45.7	50.4	55.7	47.2	49.5	54.3	59.1
	LWB	37.3	42.5	47.9	53.3	39.5	44.9	50.2	55.7	42.5	48.4	53.7	59.1
	TCG	47.8	52.0	56.8	62.1	50.7	54.5	59.5	65.0	56.4	58.5	63.6	69.1
	SHG	46.8	42.2	37.2	31.6	50.7	46.1	40.1	33.7	56.4	53.4	45.7	37.7
	TC	46.6	50.8	55.6	60.9	49.4	53.3	58.3	63.7	55.1	57.2	62.4	67.9
	kW	3.74	3.78	3.83	3.89	3.77	3.81	3.86	3.91	3.83	3.85	3.90	3.96
85 (29.4)	CMP	3.39	3.43	3.48	3.54	3.42	3.46	3.51	3.56	3.48	3.50	3.55	3.61
	LDB	39.9	44.2	48.9	54.2	42.8	46.6	51.4	56.5	48.4	50.3	55.0	59.9
	LWB	38.2	43.5	48.8	54.2	40.3	45.8	51.1	56.5	43.1	49.1	54.4	59.8
	TCG	46.0	49.7	54.3	59.4	48.8	52.1	56.8	61.9	54.1	55.7	60.5	65.7
	SHG	45.7	41.0	36.0	30.5	48.8	44.7	38.8	32.5	54.1	51.8	44.2	36.3
	TC	44.8	48.5	53.1	58.1	47.5	50.8	55.6	60.7	52.9	54.4	59.2	64.5
95 (35)	kW	4.17	4.21	4.26	4.31	4.20	4.24	4.28	4.34	4.26	4.27	4.32	4.37
	CMP	3.82	3.86	3.91	3.96	3.85	3.89	3.93	3.99	3.91	3.92	3.97	4.02
	LDB	40.8	45.3	50.0	55.2	44.3	47.6	52.3	57.4	49.7	51.2	55.9	60.6
	LWB	39.1	44.5	49.8	55.2	41.0	46.6	51.9	57.4	43.8	49.8	55.1	60.5
	TCG	43.9	47.4	51.7	56.5	46.8	49.4	53.9	58.7	51.7	52.8	57.2	62.1
	SHG	43.9	40.0	34.7	29.3	46.8	43.3	37.4	31.3	51.7	50.1	42.6	34.8
105 (40.6)	TC	42.7	46.2	50.5	55.2	45.5	48.2	52.7	57.5	50.4	51.5	56.0	60.9
	kW	4.77	4.81	4.85	4.90	4.80	4.83	4.88	4.93	4.85	4.86	4.91	4.96
	CMP	4.42	4.46	4.50	4.55	4.45	4.48	4.53	4.58	4.50	4.51	4.56	4.61
	LDB	42.4	46.2	51.1	56.2	45.8	48.6	53.4	58.2	51.1	52.2	56.7	61.4
	LWB	40.0	45.4	50.8	56.2	41.8	47.5	52.8	58.2	44.4	50.5	55.8	61.2
	TCG	42.0	44.9	48.9	53.3	44.6	46.6	50.9	55.3	49.1	49.7	53.8	58.3
115 (46.1)	SHG	42.0	38.6	33.3	28.1	44.6	41.7	36.0	30.0	49.1	48.2	41.0	33.3
	TC	40.8	43.6	47.6	52.1	43.3	45.4	49.6	54.1	47.9	48.5	52.5	57.1
	kW	5.16	5.19	5.22	5.27	5.18	5.20	5.24	5.29	5.22	5.23	5.27	5.31
	CMP	4.81	4.84	4.87	4.92	4.83	4.85	4.89	4.94	4.87	4.88	4.92	4.96
	LDB	44.1	47.3	52.3	57.2	47.4	49.8	54.4	59.2	52.6	53.3	57.6	62.3
	LWB	40.9	46.5	51.8	57.2	42.6	48.5	53.8	59.2	45.2	51.3	56.6	62.0
125 (51.7)	TCG	39.8	42.0	45.8	49.9	42.2	43.6	47.5	51.6	46.3	46.4	50.0	54.0
	SHG	39.8	37.0	31.8	26.7	42.2	40.0	34.3	28.5	46.3	46.4	39.2	31.5
	TC	38.5	40.8	44.6	48.6	40.9	42.4	46.3	50.4	45.1	45.2	48.8	52.8
	kW	5.70	5.72	5.75	5.80	5.72	5.74	5.77	5.81	5.76	5.76	5.79	5.83
	CMP	5.35	5.37	5.40	5.45	5.37	5.39	5.42	5.46	5.41	5.41	5.44	5.48
	LDB	46.0	48.7	53.6	58.4	49.2	51.1	55.6	60.3	54.2	54.2	58.6	63.2
125 (51.7)	LWB	41.9	47.7	53.0	58.4	43.5	49.5	54.8	60.2	45.9	52.1	57.4	62.8
	TCG	37.2	38.8	42.3	45.9	39.4	40.3	43.7	47.2	43.0	43.1	45.6	49.0
	SHG	37.2	35.1	30.1	25.2	39.4	38.1	32.5	26.7	43.0	42.8	37.1	29.5
	TC	36.0	37.6	41.0	44.6	38.2	39.1	42.5	46.0	41.8	41.9	44.4	47.8
	kW	6.27	6.29	6.31	6.35	6.28	6.29	6.32	6.36	6.32	6.31	6.34	6.37
	CMP	5.92	5.94	5.96	6.00	5.93	5.94	5.97	6.01	5.97	5.96	5.99	6.02
125 (51.7)	LDB	48.3	50.4	55.1	59.7	51.3	52.5	56.9	61.5	56.1	56.3	59.8	64.4
	LWB	43.1	48.9	54.2	59.7	44.5	50.6	55.9	61.3	46.8	52.9	58.4	63.8

Rating Condition.
Not recommended for long-term operation

BF – Bypass Factor
 CMP – Compressor
 Edb – Entering Dry Bulb
 Ewb – Entering Wet Bulb
 kW – Total Power
 LDB – Leaving Dry Bulb
 LWB – Leaving Wet Bulb
 SHG – Gross Sensible Capacity (1000 Btuh)
 TC – Total Net Cooling Capacity (1000 Btuh)
 TCG – Gross Cooling Capacity (1000 Btuh)

NOTES:

1. Direct interpolation is permissible. Do not extrapolate.
2. The SHG is based on 80°F (26.7°C) edb temperature of air entering indoor coil.

Below 80°F (26.7°C) edb, subtract (corr factor x cfm) from SHG.
 Above 80°F (26.7°C) edb, add (corr factor x cfm) to SHG.
 Correction Factor = 1.10 x (1 – BF) x (edb – 80).

40QAC/38HDR – 40QAQ/38QRF

PERFORMANCE DATA (CONT.)

INSTANTANEOUS AND INTEG. HEATING RATINGS 40QAQ024 / 38QRR018

40QAC/38HDR -- 40QAQ/38QRR

Air Temperature Entering Indoor Unit °F (°C)	Indoor Airflow (CFM) L-M-H	Item	Air Temperature Entering Outdoor Coil °F (°C)									
			17 (-8.3)		27 (-2.8)		37 (2.8)		47 (8.3)		57 (13.9)	
			Instant. Rating	Integ. Rating	Instant. Rating	Integ. Rating	Instant. Rating	Integ. Rating	Instant. Rating	Integ. Rating	Instant. Rating	Integ. Rating
55 (12.8)	320	Cap	9.67	8.81	11.81	10.49	13.85	12.60	17.07	17.07	17.69	17.69
		kW	1.17		1.31		1.45		1.58		1.63	
	400	Cap	9.92	9.04	12.10	10.75	14.17	12.89	17.39	17.39	18.01	18.01
		kW	1.11		1.22		1.33		1.44		1.45	
	480	Cap	10.01	9.12	12.25	10.88	14.41	13.11	17.84	17.84	18.46	18.46
		kW	1.06		1.11		1.16		1.20		1.25	
60 (15.6)	320	Cap	9.56	8.72	11.84	10.52	13.67	12.44	16.82	16.82	17.56	17.56
		kW	1.22		1.29		1.37		1.44		1.49	
	400	Cap	9.74	8.88	11.99	10.65	14.00	12.74	17.22	17.22	17.95	17.95
		kW	1.16		1.22		1.28		1.33		1.38	
	480	Cap	9.84	8.97	12.06	10.71	14.14	12.87	17.53	17.53	17.99	17.99
		kW	1.12		1.17		1.21		1.26		1.30	
65 (18.3)	320	Cap	9.35	8.53	11.67	10.37	13.63	12.41	16.53	16.53	17.26	17.26
		kW	1.27		1.37		1.47		1.56		1.56	
	400	Cap	9.56	8.72	11.83	10.50	13.85	12.60	16.98	16.98	17.63	17.63
		kW	1.22		1.28		1.34		1.41		1.45	
	480	Cap	9.68	8.83	11.92	10.58	14.09	12.82	17.26	17.26	17.70	17.70
		kW	1.18		1.23		1.28		1.33		1.36	
70 (21.1)	320	Cap	9.15	8.35	11.45	10.17	13.38	12.18	16.45	16.45	16.94	16.94
		kW	1.33		1.41		1.48		1.55		1.65	
	400	Cap	9.37	8.55	11.70	10.39	13.66	12.43	16.70	16.70	17.50	17.50
		kW	1.28		1.34		1.41		1.48		1.52	
	480	Cap	9.50	8.66	11.84	10.52	13.88	12.63	17.00	17.00	17.70	17.70
		kW	1.24		1.29		1.35		1.40		1.44	
75 (23.9)	320	Cap	8.95	8.66	11.45	10.17	13.04	8.66	15.69	15.69	16.60	16.60
		kW	1.40		1.51		1.62		1.72		1.75	
	400	Cap	9.15	8.89	11.66	10.35	13.44	8.89	16.47	16.47	17.00	17.00
		kW	1.34		1.42		1.50		1.57		1.64	
	480	Cap	9.28	8.46	11.66	10.35	13.55	12.33	16.76	16.76	17.11	17.11
		kW	1.30		1.36		1.41		1.46		1.56	
80 (26.7)	320	Cap	8.71	7.94	11.21	9.96	13.07	11.90	15.32	15.32	15.91	15.91
		kW	1.46		1.54		1.62		1.70		1.97	
	400	Cap	8.91	8.13	11.45	10.17	13.20	12.01	15.45	15.45	16.37	16.37
		kW	1.41		1.47		1.53		1.59		1.96	
	480	Cap	9.09	8.66	11.59	10.30	13.40	12.20	15.65	15.65	16.57	16.57
		kW	1.36		1.43		1.51		1.58		1.76	

Rating Condition.

Not recommended for long-term operation

Cap – Heating Capacity (1000 Btuh), includes indoor fan motor heat.

kW – Total power input. Includes compressor motor power input, outdoor fan motor power input, and indoor fan motor power input.

NOTE: Integ. Capacity is maximum (instantaneous) capacity less the effect of frost on the outdoor coil and the heat to defrost it.

PERFORMANCE DATA (CONT.)

INSTANTANEOUS AND INTEG. HEATING RATINGS 40QAQ024 / 38QRR024

Air Temperature Entering Indoor Unit °F (°C)	Indoor Airflow (CFM) L-M-H	Item	Air Temperature Entering Outdoor Coil °F (°C)									
			17 (-8.3)		27 (-2.8)		37 (2.8)		47 (8.3)		57 (13.9)	
			Instant. Rating	Integ. Rating	Instant. Rating	Integ. Rating	Instant. Rating	Integ. Rating	Instant. Rating	Integ. Rating	Instant. Rating	Integ. Rating
55 (12.8)	400	Cap	14.39	13.12	17.34	15.40	20.21	18.39	24.04	24.04	27.43	27.43
		kW	1.55		1.60		1.74		1.94		2.34	
	480	Cap	14.60	13.31	17.60	15.63	20.38	18.54	24.53	24.53	28.21	28.21
		kW	1.48		1.51		1.68		1.81		2.21	
	550	Cap	14.69	13.39	17.70	15.72	20.82	18.94	24.78	24.78	28.65	28.65
		kW	1.43		1.48		1.57		1.75		2.06	
60 (15.6)	400	Cap	14.19	12.94	17.12	15.20	19.98	18.18	23.69	23.69	27.12	27.12
		kW	1.63		1.68		1.82		2.03		2.42	
	480	Cap	14.37	13.10	17.40	15.46	20.29	18.47	24.19	24.19	27.66	27.66
		kW	1.55		1.58		1.72		1.90		2.34	
	550	Cap	14.49	13.21	17.58	15.62	20.66	18.80	24.49	24.49	28.49	28.49
		kW	1.50		1.52		1.61		1.82		2.42	
65 (18.3)	400	Cap	14.00	12.77	16.89	15.00	19.74	17.96	23.36	23.36	26.80	26.80
		kW	1.70		1.76		1.90		2.11		2.50	
	480	Cap	14.18	12.93	17.18	15.26	20.13	18.32	23.85	23.85	27.26	27.26
		kW	1.63		1.66		1.77		1.99		2.42	
	550	Cap	14.29	13.03	17.34	15.40	20.23	18.41	24.14	24.14	27.88	27.88
		kW	1.58		1.60		1.74		1.90		2.30	
70 (21.1)	400	Cap	13.80	12.58	16.72	14.85	19.44	17.69	23.00	23.00	26.42	26.42
		kW	1.78		1.83		1.98		2.23		2.60	
	480	Cap	13.99	12.75	16.95	15.05	19.81	18.03	23.43	23.43	26.98	26.98
		kW	1.71		1.74		1.88		2.11		2.50	
	550	Cap	14.10	12.86	17.11	15.20	19.98	18.19	23.80	23.80	27.38	27.38
		kW	1.66		1.68		1.82		2.00		2.35	
75 (23.9)	400	Cap	13.57	8.66	16.51	14.66	19.22	8.66	22.53	22.53	25.71	25.71
		kW	1.86		1.91		2.07		2.36		2.79	
	480	Cap	13.77	8.89	16.73	14.86	19.55	8.89	23.16	23.16	26.54	26.54
		kW	1.79		1.82		1.94		2.20		2.56	
	550	Cap	13.90	12.67	16.87	14.98	19.71	17.94	23.37	23.37	26.95	26.95
		kW	1.75		1.77		1.91		2.11		2.50	
80 (26.7)	400	Cap	13.32	12.15	16.00	14.21	18.80	17.11	22.11	22.11	25.30	25.30
		kW	1.94		1.99		2.22		2.43		2.89	
	480	Cap	13.54	12.34	16.52	14.67	19.12	17.40	22.97	22.97	26.05	26.05
		kW	1.87		1.91		2.10		2.25		2.76	
	550	Cap	13.67	8.66	16.65	14.79	19.38	17.64	23.27	23.27	26.27	26.27
		kW	1.83		1.86		2.02		2.15		2.65	

Rating Condition.
Not recommended for long-term operation

Cap – Heating Capacity (1000 Btu/h), includes indoor fan motor heat.

kW – Total power input. Includes compressor motor power input, outdoor fan motor power input, and indoor fan motor power input.

NOTE: Integ. Capacity is maximum (instantaneous) capacity less the effect of frost on the outdoor coil and the heat to defrost it.

40QAC/38HDR – 40QAQ/38QRF

PERFORMANCE DATA (CONT.)

INSTANTANEOUS AND INTEG. HEATING RATINGS 40QAQ036 / 38QRR030

Air Temperature Entering Indoor Unit °F (°C)	Indoor Airflow (CFM) L-M-H	Item	Air Temperature Entering Outdoor Coil °F (°C)									
			17 (-8.3)		27 (-2.8)		37 (2.8)		47 (8.3)		57 (13.9)	
			Instant. Rating	Integ. Rating	Instant. Rating	Integ. Rating	Instant. Rating	Integ. Rating	Instant. Rating	Integ. Rating	Instant. Rating	Integ. Rating
55 (12.8)	630	Cap	16.44	14.99	20.75	18.43	23.89	21.74	28.90	28.90	32.23	32.23
		kW	1.92		2.01		2.10		2.20		2.29	
	750	Cap	16.60	15.13	20.84	18.51	24.57	22.36	29.08	29.08	32.39	32.39
		kW	1.87		1.91		1.94		1.98		2.08	
	870	Cap	16.86	15.37	21.19	18.82	24.94	22.69	29.38	29.38	32.65	32.65
		kW	1.83		1.85		1.86		1.88		1.96	
60 (15.6)	400	Cap	16.12	14.70	20.61	18.31	23.66	21.53	28.67	28.67	32.00	32.00
		kW	1.99		2.09		2.19		2.29		2.40	
	480	Cap	16.37	14.92	20.89	18.55	23.93	21.77	29.07	29.07	32.25	32.25
		kW	1.94		1.99		2.05		2.10		2.18	
	550	Cap	16.55	15.09	21.04	18.68	24.42	22.22	28.68	28.68	32.43	32.43
		kW	1.90		1.93		1.95		1.98		2.08	
65 (18.3)	400	Cap	15.53	14.16	20.30	18.03	22.84	20.79	27.99	27.99	30.79	30.79
		kW	2.10		2.21		2.32		2.44		2.62	
	480	Cap	16.06	14.64	20.62	18.31	23.74	21.61	28.79	28.79	31.67	31.67
		kW	2.01		2.08		2.15		2.22		2.31	
	550	Cap	16.21	14.78	20.80	18.47	24.13	21.96	29.13	29.13	32.05	32.05
		kW	1.97		2.01		2.06		2.10		2.22	
70 (21.1)	400	Cap	15.08	13.75	19.93	17.70	22.78	20.73	27.44	27.44	30.18	30.18
		kW	2.18		2.29		2.41		2.52		2.76	
	480	Cap	15.59	14.22	20.28	18.01	23.25	21.16	28.32	28.32	31.15	31.15
		kW	2.10		2.21		2.31		2.41		2.45	
	550	Cap	15.71	14.33	20.50	18.21	23.50	21.38	28.84	28.84	31.72	31.72
		kW	2.05		2.11		2.18		2.24		2.31	
75 (23.9)	400	Cap	14.79	8.66	19.57	17.38	22.47	8.66	26.91	26.91	29.60	29.60
		kW	2.23		2.35		2.46		2.57		2.80	
	480	Cap	15.10	8.89	19.89	17.67	22.56	8.89	27.54	27.54	30.29	30.29
		kW	2.19		2.28		2.38		2.47		2.59	
	550	Cap	15.41	14.05	20.13	17.87	23.13	21.05	28.33	28.33	31.17	31.17
		kW	2.13		2.21		2.28		2.35		2.45	
80 (26.7)	400	Cap	14.26	13.01	19.21	17.06	22.24	20.24	26.69	26.69	29.35	29.35
		kW	2.31		2.40		2.49		2.58		3.18	
	480	Cap	14.70	13.40	19.52	17.34	22.56	20.53	27.10	27.10	29.81	29.81
		kW	2.25		2.35		2.45		2.55		2.77	
	550	Cap	14.80	8.66	19.73	17.53	22.64	20.60	27.79	27.79	30.56	30.56
		kW	2.24		2.31		2.38		2.45		2.59	

Rating Condition.
Not recommended for long-term operation

Cap – Heating Capacity (1000 Btu/h), includes indoor fan motor heat.

kW – Total power input. Includes compressor motor power input, outdoor fan motor power input, and indoor fan motor power input.

NOTE: Integ. Capacity is maximum (instantaneous) capacity less the effect of frost on the outdoor coil and the heat to defrost it.

40QAC/38HDR -- 40QAQ/38QRR

PERFORMANCE DATA (CONT.)

INSTANTANEOUS AND INTEG. HEATING RATINGS 40QAQ036 / 38QRR036

Air Temperature Entering Indoor Unit °F (°C)	Indoor Airflow (CFM) L-M-H	Item	Air Temperature Entering Outdoor Coil °F (°C)									
			17 (-8.3)		27 (-2.8)		37 (2.8)		47 (8.3)		57 (13.9)	
			Instant. Rating	Integ. Rating	Instant. Rating	Integ. Rating	Instant. Rating	Integ. Rating	Instant. Rating	Integ. Rating	Instant. Rating	Integ. Rating
55 (12.8)	630	Cap	19.18	17.48	23.81	21.15	27.49	25.02	32.28	32.28	36.27	36.27
		kW	2.29		2.38		2.48		2.58		2.77	
	750	Cap	19.56	17.83	24.21	21.50	28.14	25.60	32.89	32.89	36.97	36.97
		kW	2.20		2.27		2.35		2.42		2.56	
	870	Cap	19.82	18.07	24.46	21.73	20.80	18.93	33.31	33.31	37.61	37.61
		kW	2.13		2.19		2.24		2.29		2.41	
60 (15.6)	400	Cap	18.73	17.08	23.41	20.79	19.96	18.17	31.71	31.71	35.66	35.66
		kW	2.39		2.51		2.63		2.75		2.90	
	480	Cap	19.15	17.46	23.84	21.17	19.43	17.68	23.22	23.22	36.48	36.48
		kW	2.29		2.25		2.21		2.16		2.69	
	550	Cap	19.44	17.72	24.13	21.43	18.84	17.15	19.34	19.34	37.10	37.10
		kW	2.23		2.15		2.06		1.98		2.53	
65 (18.3)	400	Cap	18.25	16.64	22.98	20.41	26.73	24.33	31.26	31.26	35.17	35.17
		kW	2.49		2.61		2.73		2.85		3.03	
	480	Cap	18.68	17.03	23.43	20.81	27.17	24.72	32.05	32.05	35.98	35.98
		kW	2.40		2.48		2.55		2.63		2.82	
	550	Cap	18.99	17.32	23.75	21.09	27.55	25.07	32.48	32.48	36.59	36.59
		kW	2.33		2.40		2.47		2.54		2.66	
70 (21.1)	400	Cap	17.73	16.16	22.50	19.98	26.34	23.97	30.75	30.75	34.49	34.49
		kW	2.59		2.71		2.83		2.95		3.27	
	480	Cap	18.18	16.58	23.00	20.43	26.82	24.40	31.59	31.59	35.53	35.53
		kW	2.51		2.58		2.66		2.74		3.00	
	550	Cap	18.51	16.87	23.33	20.72	27.12	24.68	32.00	32.00	36.09	36.09
		kW	2.44		2.51		2.59		2.67		2.79	
75 (23.9)	400	Cap	17.18	8.66	21.95	19.50	25.88	8.66	30.25	30.25	33.76	33.76
		kW	2.70		2.82		2.95		3.07		3.45	
	480	Cap	17.64	8.89	22.51	19.99	26.39	8.89	31.09	31.09	34.98	34.98
		kW	2.61		2.70		2.78		2.87		3.08	
	550	Cap	17.98	16.40	22.89	20.33	26.73	24.32	31.60	31.60	35.57	35.57
		kW	2.54		2.61		2.67		2.74		2.93	
80 (26.7)	400	Cap	16.60	15.13	21.38	18.99	25.41	23.12	29.68	29.68	33.34	33.34
		kW	2.80		2.93		3.06		3.19		3.55	
	480	Cap	17.07	15.57	21.95	19.49	25.94	23.60	30.37	30.37	34.42	34.42
		kW	2.72		2.83		2.93		3.04		3.31	
	550	Cap	17.42	8.66	22.37	19.86	26.32	23.95	31.09	31.09	35.07	35.07
		kW	2.65		2.73		2.80		2.87		3.11	

Rating Condition.
Not recommended for long-term operation

Cap – Heating Capacity (1000 Btu/h), includes indoor fan motor heat.

kW – Total power input. Includes compressor motor power input, outdoor fan motor power input, and indoor fan motor power input.

NOTE: Integ. Capacity is maximum (instantaneous) capacity less the effect of frost on the outdoor coil and the heat to defrost it.

40QAC/38HDR – 40QAQ/38QRF

PERFORMANCE DATA (CONT.)

INSTANTANEOUS AND INTEG. HEATING RATINGS 40QAQ048 / 38QRR048

Air Temperature Entering Indoor Unit °F (°C)	Indoor Airflow (CFM) L-M-H	Item	Air Temperature Entering Outdoor Coil °F (°C)									
			17 (-8.3)		27 (-2.8)		37 (2.8)		47 (8.3)		57 (13.9)	
			Instant. Rating	Integ. Rating	Instant. Rating	Integ. Rating	Instant. Rating	Integ. Rating	Instant. Rating	Integ. Rating	Instant. Rating	Integ. Rating
55 (12.8)	820	Cap	27.65	25.21	33.34	29.61	38.58	35.11	45.46	45.46	50.81	50.81
		kW	3.24		3.44		3.64		3.84		4.14	
	975	Cap	28.09	25.61	33.91	30.12	39.36	35.81	46.08	46.08	51.85	51.85
		kW	3.12		3.28		3.44		3.60		3.86	
	1130	Cap	28.52	26.01	34.32	30.48	39.76	36.19	46.61	46.61	52.82	52.82
		kW	3.03		3.17		3.30		3.43		3.66	
60 (15.6)	820	Cap	27.09	24.70	32.79	29.12	38.22	34.78	44.77	44.77	50.24	50.24
		kW	3.39		3.59		3.80		4.00		4.32	
	975	Cap	27.62	25.18	33.40	29.67	38.90	35.40	45.56	45.56	51.24	51.24
		kW	3.27		3.44		3.60		3.77		4.04	
	1130	Cap	27.99	25.52	33.80	30.02	39.32	35.78	46.08	46.08	51.94	51.94
		kW	3.17		3.32		3.46		3.60		3.83	
65 (18.3)	820	Cap	26.49	24.15	32.21	28.60	37.67	34.28	44.22	44.22	49.61	49.61
		kW	3.53		3.74		3.96		4.17		4.50	
	975	Cap	27.03	24.64	32.83	29.16	38.37	34.92	45.02	45.02	50.60	50.60
		kW	3.41		3.59		3.77		3.95		4.22	
	1130	Cap	27.41	24.99	33.26	29.54	38.83	35.33	45.55	45.55	51.32	51.32
		kW	3.32		3.47		3.62		3.77		4.01	
70 (21.1)	820	Cap	25.86	23.58	31.59	28.05	37.08	33.74	43.67	43.67	48.91	48.91
		kW	3.67		3.89		4.12		4.35		4.68	
	975	Cap	26.42	24.09	32.23	28.63	37.80	34.40	44.50	44.50	49.98	49.98
		kW	3.55		3.74		3.94		4.13		4.41	
	1130	Cap	26.80	24.43	32.67	29.02	38.28	34.84	45.01	45.01	50.68	50.68
		kW	3.46		3.63		3.79		3.95		4.20	
75 (23.9)	820	Cap	25.21	8.66	30.94	27.48	36.46	8.66	43.29	43.29	48.29	48.29
		kW	3.81		4.05		4.30		4.54		4.87	
	975	Cap	25.77	8.89	31.59	28.06	37.20	8.89	44.18	44.18	49.33	49.33
		kW	3.70		3.90		4.11		4.32		4.60	
	1130	Cap	26.16	23.85	32.05	28.47	37.70	34.31	44.53	44.53	50.03	50.03
		kW	3.61		3.79		3.96		4.14		4.40	
80 (26.7)	820	Cap	24.50	22.34	30.26	26.87	35.81	32.59	42.95	42.95	47.61	47.61
		kW	3.95		4.21		4.47		4.73		5.06	
	975	Cap	25.08	22.86	30.92	27.46	36.56	33.27	43.74	43.74	48.63	48.63
		kW	3.84		4.06		4.29		4.51		4.80	
	1130	Cap	25.46	8.66	31.39	27.88	37.08	33.74	44.22	44.22	49.36	49.36
		kW	3.76		3.95		4.14		4.33		4.59	

Rating Condition.
Not recommended for long-term operation

Cap – Heating Capacity (1000 Btu/h), includes indoor fan motor heat.

kW – Total power input. Includes compressor motor power input, outdoor fan motor power input, and indoor fan motor power input.

NOTE: Integ. Capacity is maximum (instantaneous) capacity less the effect of frost on the outdoor coil and the heat to defrost it.

40QAC/38HDR -- 40QAQ/38QRR

PERFORMANCE DATA (CONT.)

INSTANTANEOUS AND INTEG. HEATING RATINGS 40QAQ060 / 38QRR060

Air Temperature Entering Indoor Unit °F (°C)	Indoor Airflow (CFM) L-M-H	Item	Air Temperature Entering Outdoor Coil °F (°C)									
			17 (-8.3)		27 (-2.8)		37 (2.8)		47 (8.3)		57 (13.9)	
			Instant. Rating	Integ. Rating	Instant. Rating	Integ. Rating	Instant. Rating	Integ. Rating	Instant. Rating	Integ. Rating	Instant. Rating	Integ. Rating
55 (12.8)	1040	Cap	31.97	29.15	38.41	34.12	42.34	38.53	53.78	53.78	57.10	57.10
		kW	3.73		3.87		4.02		4.16		4.26	
	1220	Cap	32.33	29.48	39.03	34.67	42.99	39.12	54.83	54.83	58.41	58.41
		kW	3.62		3.76		3.89		4.03		4.14	
	1600	Cap	32.89	29.99	39.62	35.18	43.44	39.53	55.52	55.52	59.30	59.30
		kW	3.44		3.55		3.65		3.76		3.84	
60 (15.6)	1040	Cap	31.21	28.46	37.64	33.43	41.36	37.64	52.67	52.67	55.60	55.60
		kW	3.85		4.00		4.15		4.31		4.40	
	1220	Cap	31.81	29.00	38.50	34.20	42.51	38.68	54.28	54.28	57.69	57.69
		kW	3.76		3.91		4.06		4.21		4.31	
	1600	Cap	32.37	29.52	39.16	34.78	43.10	39.23	55.05	55.05	58.69	58.69
		kW	3.59		3.70		3.82		3.94		4.02	
65 (18.3)	1040	Cap	30.58	27.88	36.98	32.85	40.71	37.04	51.95	51.95	55.16	55.16
		kW	4.01		4.17		4.33		4.48		4.60	
	1220	Cap	31.26	28.50	37.93	33.69	41.93	38.16	53.82	53.82	57.17	57.17
		kW	3.90		4.06		4.22		4.38		4.49	
	1600	Cap	31.81	29.01	38.60	34.28	42.72	38.88	54.54	54.54	58.11	58.11
		kW	3.73		3.86		3.98		4.11		4.20	
70 (21.1)	1040	Cap	30.11	27.46	36.27	32.21	39.96	36.36	51.01	51.01	54.24	54.24
		kW	4.19		4.35		4.50		4.65		4.77	
	1220	Cap	30.64	27.94	37.29	33.12	41.26	37.54	53.08	53.08	56.57	56.57
		kW	4.05		4.22		4.39		4.55		4.68	
	1600	Cap	31.22	28.46	37.97	33.72	42.06	38.27	54.03	54.03	57.51	57.51
		kW	3.88		4.02		4.16		4.30		4.39	
75 (23.9)	1040	Cap	29.34	8.66	35.76	31.76	39.08	8.66	49.96	49.96	53.15	53.15
		kW	4.36		4.51		4.67		4.83		4.95	
	1220	Cap	29.93	8.89	36.60	32.51	40.51	8.89	52.18	52.18	55.80	55.80
		kW	4.20		4.38		4.55		4.72		4.86	
	1600	Cap	30.55	27.85	37.27	33.10	41.35	37.63	53.38	53.38	56.87	56.87
		kW	4.01		4.17		4.32		4.48		4.58	
80 (26.7)	1040	Cap	28.69	26.16	35.12	31.19	38.17	34.74	48.75	48.75	51.91	51.91
		kW	4.54		4.69		4.85		5.00		5.12	
	1220	Cap	29.22	26.64	35.82	31.82	39.52	35.97	51.08	51.08	54.65	54.65
		kW	4.38		4.55		4.71		4.88		5.02	
	1600	Cap	29.82	8.66	36.52	32.44	40.52	36.87	52.37	52.37	56.17	56.17
		kW	4.16		4.32		4.49		4.65		4.77	

Rating Condition.
Not recommended for long-term operation

Cap – Heating Capacity (1000 Btu/h), includes indoor fan motor heat.

kW – Total power input. Includes compressor motor power input, outdoor fan motor power input, and indoor fan motor power input.

NOTE: Integ. Capacity is maximum (instantaneous) capacity less the effect of frost on the outdoor coil and the heat to defrost it.

40QAC/38HDR – 40QAQ/38QRF

APPLICATION DATA

UNIT SELECTION

The ceiling-suspended units are available as cooling only or heat pump with electric heat. For most applications, the cooling load dictates the size selection of the unit. Select equipment to either match or be slightly less than anticipated peak load. This provides better humidity control, fewer unit cycles, and less part-load operation.

For units used in spaces with high sensible loads, base equipment selection on unit sensible load, not on total anticipated load. Adjust for anticipated room wet bulb temperature to avoid under-sizing equipment.

UNIT MOUNTING (INDOOR)

Unit leveling - For reliable operation, units should be level in all planes. The 40QAC/QAQ ceiling-suspended fan coils may have a slight pitch, but only toward the drain connection.

Clearance - Refer to Fig. 9 for required CE clearances.

Unit location - When selecting unit location, select a location that will provide the best air circulation for the room.

The 40QAC/QAQ ceiling-suspended units should be mounted near the ceiling and against a wall. The unit should be centered in the room for best performance. Locating the unit on an outside wall will make piping easier, but units can also be mounted away from a wall if desired. If unit is mounted away from a wall, the rear panel of the unit may need a field-supplied trim strip for improved appearance. Locate the fan coil return over an area which is not normally occupied for quietest operation. Do not block air discharge for a minimum of 15 ft (4.6 m) to prevent dumping of cold air and drafts.

Support - The 40QAC/QAQ units are installed using the mounting brackets supplied with the unit. The structure should provide adequate support for the weight of the unit. Refer to the *Physical Data* section in this document for fan coil weights.

UNIT MOUNTING (OUTDOOR)

Unit leveling - For reliable operation, units should be level in all planes.

Clearance - Minimum clearance, as shown in Fig. 8, must be provided for airflow. The condensing units are designed for free-blow application. Air inlets and outlets should not be restricted.

Unit location - A location which is convenient to installation and not exposed to strong wind. If unit is exposed to strong winds it is recommended that a wind baffle accessory be used.

A location which can bear the weight of outdoor unit and where the outdoor unit can be mounted in a level position.

Mounting Pad - The minimum mounting pad dimensions are listed in the following table:

Unit Model	Minimum Mounting Pad Dimensions ft.-in. (mm)
38HDR018, 024, 030 38QRR018, 024	1'-11" X 3'-6" (584.2 X 1066.8)
38HDR036, 048, 060 38QRR030, 036, 048, 060	2'-0" X 4'-2" (609.6 X 1270)

SYSTEM OPERATING CONDITIONS

Cooling operating range:

	Maximum		Minimum	
	DB °F (°C)	WB °F (°C)	DB °F (°C)	WB °F (°C)
Outdoor Unit	125 (51.7)	-	55 (12.8)	-
Indoor Unit	95 (35)	71 (21.7)	67 (19.4)	57 (13.9)

Heating operating range:

	Maximum		Minimum	
	DB °F (°C)	WB °F (°C)	DB °F (°C)	WB °F (°C)
Outdoor Unit	75 (23.9)	67 (19.4)	-20 (-28.9)	-
Indoor Unit	80 (26.7)	71 (21.7)	55 (12.8)	-

LOW AMBIENT OPERATION

Both cooling only and heat pumps will operate in cooling down to 55°F (12.8°C).

When equipped with a low ambient controller, the unit will operate down to -20°F (-28.9°C).

For proper operation, a Winter Start Kit (bypasses the Low Pressure Switch), a Crankcase Heater (prevents refrigerant migration during compressor-off cycle), and a Wind Baffle should also be installed. On heat pumps, a Winter Start Kit is not required. An Isolation Relay to bypass the Low Ambient Controller when unit is in heating mode is required.

METERING DEVICES

For cooling only on units, a TXV in the indoor unit controls the refrigerant flow.

On heat pumps, an Accurator in the outdoor unit controls the refrigerant flow in heating and another Accurator in the indoor unit (except size 060, which has a TXV) controls the refrigerant flow in cooling.

DRAIN CONNECTIONS

The drain connection on the ceiling-suspended unit is located on the right hand side when facing the unit discharge.

When the unit is installed close to an outside wall, a downward sloped condensate line can be used to dispose of the water (do not trap condensate line). If this is not feasible, an accessory condensate pump that can be installed inside the unit is available and will provide up to 20 inches (508 mm) of lift. When using a condensate pump, the drain pipe can be routed through the top of the unit, if desired.

REFRIGERANT LINES

General Guides:

1. Refrigerant lines can access the ceiling-suspended unit from either the top-right or rear-right when facing the unit.
2. Refrigerant lines should not be buried in the ground. If it is necessary to bury the lines, not more than 36-in (914 mm) should be buried. Provide a minimum 6-in (152 mm) vertical rise to the service valves to prevent refrigerant migration.
3. On cooling only units, the suction line must be insulated. On heat pumps, insulate both lines. Use a minimum of 1/2-in. (12.7 mm) thick insulation. Closed-cell insulation is recommended in all long-line applications.
4. Special consideration should be given to isolating interconnecting tubing from the building structure. Isolate the tubing so that vibration or noise is not transmitted into the structure.

NOTE: Since the same outdoor unit can be matched with different types of indoor units, it may not have enough refrigerant charge. Refer to the *Physical Data* tables in this document to determine if additional charge is required.

Long Line Applications:

The following table indicates the maximum line lengths that can be used with the high wall systems:

Item	Max Length Allowed ft (m)
Total Piping	200 (61)
Max Lift (fan coil above)	65 (20)
Max Drop (fan coil below)	200 (61)

For line lengths over 25 ft (7.6 m), .6 oz of charge should be added for each additional foot up to the maximum allowed.

For line lengths over 80 ft (24.4 m), certain accessories and adjustments to the piston sizes are also required.

Refer to the *Duct Free Split Systems Long Line Guide* for additional information.

CONTROLS

Ceiling-suspended fan coil units have a relay board which controls system operation in response to the room thermostat.

The 40QAC/QAQ unit has 4 operating modes:

- Fan Only
- Auto (heat pump models only)
- Heating (heat pump models only)
- Cooling

FAN ONLY - In Fan Only mode, the system filters and circulates the room air without changing the room air temperature.

AUTO - In Auto mode, the system will automatically select one of the following operating modes: cooling, or heating depending on the selected thermostat set point.

HEATING - In the Heating mode, the system heats and filters room air.

COOLING - In Cooling mode, the system cools, dries and filters room air.

SEQUENCE OF OPERATION

Increased demand for cooling (heat pump systems)

1. When the room thermostat senses a demand for cooling, the fan coil relay board is energized and the indoor fan will start in the selected speed (if it is not already operating).
2. The reversing valve is energized at all times when in cooling mode.
3. The internal condensate pump (if so equipped) runs whenever the reversing valve is energized. The internal condensate pump (if so equipped) runs whenever there is a demand for cooling.
4. As long as the condensate float switch and freeze protection thermostat are closed, the cooling relays in the fan coil unit will close. This energizes the compressor and outdoor fan in the outdoor unit. The compressor will continue to operate until the room thermostat is satisfied.
5. When the cooling demand is satisfied, the compressor and outdoor fan will stop. If the system is in Auto. mode, the indoor fan will stop with the compressor. If the unit has the accessory ventilation kit, the ventilation fan will operate whenever the indoor fan is set for medium or high speed.

Increased demand for heating (heat pump systems)

1. When the room thermostat senses a demand for heating, the fan coil relay board is energized .
2. The indoor fan will start in the selected speed (if it is not already operating). The reversing valve will not be energized. The internal condensate pump (if supplied) and freeze protection thermostat are not operated during heating operation.
3. The control relay closes, and the compressor and outdoor fan are energized through the defrost and the defrost timer runs.
4. Once every 90 minutes (the factory default setting) of the compressor run time, the DFB (defrost board) logic checks the defrost thermostat (DFT). If the DFT is open, the unit continues in heating operation. If the DFT is closed, the DFB switches the unit to defrost mode. The timing on the DFB may be set at either 30, 50 or 90 minutes.

Defrost

The DFB energizes the RVS (reversing valve solenoid), and the reversing valve switches to the cooling position. The relay on the DFB opens and the outdoor fan stops. The contact on the DFB is also energized, which in turn energizes the defrost relay on the fan coil relay board, turns off the electric heater and stops the indoor fan. The DFB logic checks the 10-minute defrost timer and the DFT. If the DFT opens in less than 10 minutes, the defrost board switches the unit back to normal heating operation. If the DFT remains closed the DFB switches the unit back to heating operation after 10 minutes. When the DFB changes back to heating mode, the RVR (reversing valve relay) is deenergized and the reversing valve switches back to heating operation. Both the outdoor and indoor fans come back on, and if necessary, the electric heater also turns on.

Human Interface

The 40QAC/QAQ units are controlled by a wired thermostat. For additional details on thermostat features, refer to the Owner's Manual of the individual thermostat model 53DFS250-HW.

Operating Mode Memory

After the system is turned off, or after a power failure, the system remains in the last operating mode selected. When the system is turned back on, or when power is automatically restored, operation continues in the same operating mode as when the system shut down.

Electric Heat

The 40QAQ units have electric heaters factory installed as shown in the following table.

Model	KW
40QAQ024	2
40QAQ036	3
40QAQ048	4
40QAQ060	5

The electric heater is supplementary. When the heat pump runs for at least 2 minutes and the temperature spread between the setpoint is between 3° to 8° (depending on dead-band setting), the electric heater is energized.

AIR DISTRIBUTION

All ceiling-suspended units are equipped with an automatic air sweep feature which automatically directs the airflow louvers up and down to provide optimum room air circulation. If the automatic sweep feature is not desired, temporarily start the automatic sweep using the toggle switch on the unit. When the louvers are in the desired position, turn the automatic sweep off to hold the louvers in that position.

Outside Air

Up to 30% of outside air can be introduced to the 40QAC/QAQ units through the pre-punched knockouts. If the unit is installed next to an outside wall, the Fresh Air Intake Kit can be used. A Power Ventilation Kit is also available for those applications where there is a need to overcome static pressure in the fresh air intake duct.

Air throw data

System	Size	Air Throw Data ft (m)		
		High Speed	Medium Speed	Low Speed
Cooling Only	018	25 (7.6)	20 (6.1)	16 (4.9)
	024	30 (9.1)	25 (7.6)	20 (6.1)
	030	40 (12.2)	35 (10.7)	30 (9.1)
	036	40 (12.2)	35 (10.7)	30 (9.1)
	048	45 (13.7)	42 (12.8)	38 (11.6)
	060	45 (13.7)	35 (10.7)	30 (9.1)
Heat Pumps	018	22 (6.7)	18 (5.5)	14 (4.3)
	024	27 (8.2)	23 (7.0)	18 (5.5)
	030	38 (11.6)	33 (10.1)	29 (8.8)
	036	38 (11.6)	33 (10.1)	29 (8.8)
	048	40 (12.2)	38 (11.6)	36 (11.0)
	060	40 (12.2)	30 (9.1)	26 (7.9)

SOUND DATA

Outdoor Units

Model Number	Sound Power dBa	Sound Pressure dBa
38HDR018---3	68	57
38HDR024---3	69	58
38HDR030---3	72	61
38HDR036---3/5/6	72	61
38HDR048---3/5/6	72	61
38HDR060---3/5/6	72	61
38QRR018---3	69	58
38QRR024---3	66	55
38QRR030---3	71	60
38QRR036---3/5/6	72	61
38QRR048---3/5/6	71	60
38QRR060---3/5/6	72	61

Indoor Units

Model Number	High		Medium		Low	
	Sound Power dBa	Sound Pressure dBa	Sound Power dBa	Sound Pressure dBa	Sound Power dBa	Sound Pressure dBa
40QAC024---3	58.4	47.4	57.2	46.2	54.7	43.7
40QAC036---3	68.4	57.4	66	55	62.9	51.9
40QAC048---3	67.3	56.3	66.3	55.3	—	—
40QAC060---3	70.1	59.1	68.8	57.8	65.8	54.8
40QAAQ024---3	59.4	48.4	58.5	47.5	57.8	46.8
40QAAQ036---3	68.4	57.4	66.1	55.1	63.2	52.2
40QAAQ048---3	67.3	56.3	66.3	55.3	—	—
40QAAQ060---3	70.1	59.1	68.8	57.8	65.8	54.8

NOTES:

1. Sound power ratings are per AHRI 270 and AHRI 350
2. Sound pressure ratings are estimated sound pressure, 3 feet (.91 m) from the unit, based on sound power data.

WIRING

The indoor and outdoor units have their own power supply (single point connection on unit with electric heat). Low voltage wires run between the indoor and outdoor units. Two wires are required for cooling only systems and five wires are required for heat pumps.

ELECTRICAL DATA

38HDR UNIT SIZE	V-PH-Hz	VOLTAGE RANGE*		COMPRESSOR		OUTDOOR FAN MOTOR			MIN CKT AMPS	FUSE/CKT BKR AMPS
		Min	Max	RLA	LRA	FLA	NEC Hp	kW Out		
018-31	208/230-1-60	187	253	9.0	48.0	0.8	0.125	0.09	12.1	20
024-32	208/230-1-60	187	253	13.5	58.3	0.8	0.125	0.09	17.7	25
030-31	208/230-1-60	187	253	14.1	73.0	1.5	0.250	0.19	19.1	30
036-31	208/230-1-60	187	253	14.1	77.0	1.5	0.250	0.19	19.1	30
	208/230-3-60	187	253	9.2	71.0	1.5	0.250	0.19	13.0	20
	460-3-60	414	506	5.6	38.0	0.8	0.250	0.19	7.9	10
048-32	208/230-1-60	187	253	19.9	109.0	1.5	0.250	0.19	26.4	40
	208/230-3-60	187	253	13.1	83.1	1.5	0.250	0.19	17.9	25
	460-3-60	414	506	6.1	41.0	0.8	0.250	0.19	8.4	15
060-32	208/230-1-60	187	253	26.4	134.0	1.5	0.250	0.19	34.5	60
	208/230-3-60	187	253	16.0	110.0	1.5	0.250	0.19	21.5	30
	460-3-60	414	506	7.8	52.0	0.8	0.250	0.19	10.6	15

40QAC/38HDR -- 40QAQ/38QRR

38QRR UNIT SIZE	V-PH-Hz	VOLTAGE RANGE*		COMPRESSOR		OUTDOOR FAN MOTOR			WIRE GAUGE 60°C/75°C	WIRE LENGTH 60°C/75°C	MIN CKT AMPS	FUSE/HACR CKT AMPS
		Min	Max	RLA	LRA	FLA	NEC Hp	kw Out				
018	208/230-1-60	187	253	9.0	48.0	0.80	0.125	0.09	14/14	61/62	12.1	20
024	208/230-1-60	187	253	14.4	58.3	0.80	0.125	0.09	14/14	41/39	18.8	30
030	208/230-1-60	187	253	12.8	64.0	1.5	0.25	0.19	14/14	44/42	17.5	30
036	208/230-1-60	187	253	15.5	77.0	1.5	0.25	0.19	12/12	60/57	20.9	30
	208/230-3-60	187	253	10.1	71.0	1.5	0.25	0.19	14/14	53/50	14.1	20
	460-3-60	414	506	5.6	38.0	0.80	0.25	0.19	14/14	98/94	7.9	10
048	208/230-1-60	187	253	26.5	117.0	1.5	0.25	0.19	8/10	89/54	34.6	50
	208/230-3-60	187	253	16.7	83.1	1.5	0.25	0.19	12/12	55/52	22.4	30
	460-3-60	414	506	7.3	41.0	0.80	0.25	0.19	14/14	79/75	10.0	15
060	208/230-1-60	187	253	26.4	134.0	1.5	0.25	0.19	8/10	89/54	34.5	60
	208/230-3-60	187	253	17.7	110.0	1.5	0.25	0.19	12/12	52/50	23.6	40
	460-3-60	414	506	7.8	52.0	.80	0.25	0.19	14/14	72/68	10.6	15

UNIT	VOLTAGE V-Ph-60 Hz	VOLTAGE RANGE*		FAN FLA	HEATER		POWER			MINIMUM WIRE SIZE (AWG)
		MIN.	MAX.		kW	FLA	MCA	MOCP	FLA	
40QAC024-3	208/230-1	187	253	0.50	—	—	0.63	15.0	0.50	14
40QAC036-3	208/230-1	187	253	1.30	—	—	1.60	15.0	1.30	14
40QAC048-3	208/230-1	187	253	1.60†	—	—	2.00	15.0	1.60	14
40QAC060-3	208/230-1	187	253	2.60‡	—	—	3.30	15.0	2.60	14
40QAQ024-3	208/230-1	187	253	0.50	2.00	8.66	9.29	15.0	11.29	14
40QAQ036-3	208/230-1	187	253	1.30	3.00	13.00	17.70	20.0	14.30	14
40QAQ048-3	208/230-1	187	253	1.60†	4.00	17.40	23.80	25.0	19.00	12
40QAQ060-3	208/230-1	187	253	2.60†	5.00	21.70	28.70	30.0	24.30	10

LEGEND

FLA - Full Load Amps
 LRA - Locked Rotor Amps
 MCA - Minimum Circuit Amps
 RLA - Rated Load Amps

NOTES

* Permissible limits of the voltage range at which the unit will operate satisfactorily
 † One fan is 1.1 amps, the second fan is 0.5 amps.
 ‡ Two fans each operating at 1.3 amps.



TYPICAL WIRING SCHEMATICS

- LEGEND**
- ASM — Air Sweep Motor
 - ASR — Air Sweep Relay
 - ASW — Air Sweep Switch
 - C — Contactor
 - CAP — Capacitor
 - COMP — Compressor
 - CR — Control Relay
 - CT — Current Transformer
 - DR — Delay Relay
 - EQUIP — Equipment Ground
 - GND — Ground
 - FL — Fuse Link
 - FPT — Freeze Protection Thermostat
 - FR — Fan Relay
 - FU — Fuse
 - HP — Heat Pump
 - HPS — High-Pressure Switch
 - HR — Heater Relay
 - HTR — Heater
 - HTT — Heater Temp Thermostat
 - IFM — Indoor Fan Motor
 - LPS — Low-Pressure Switch
 - OFM — Outdoor-Fan Motor
 - OL — Overload
 - PDR — Pump Delay Relay
 - PL — Plug
 - PM — Pump Motor
 - PSS — Pump Shut-off Switch
 - TB — Terminal Block
 - TRAN — Transformer

- Terminal (Marked)
- Terminal (unmarked)
- Splice
- Terminal Block
- Factory Wiring
- Field Control Wiring
- Field Power Wiring
- Printed Circuit Board
- Accessory or Optional Wiring

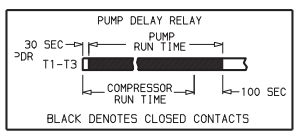
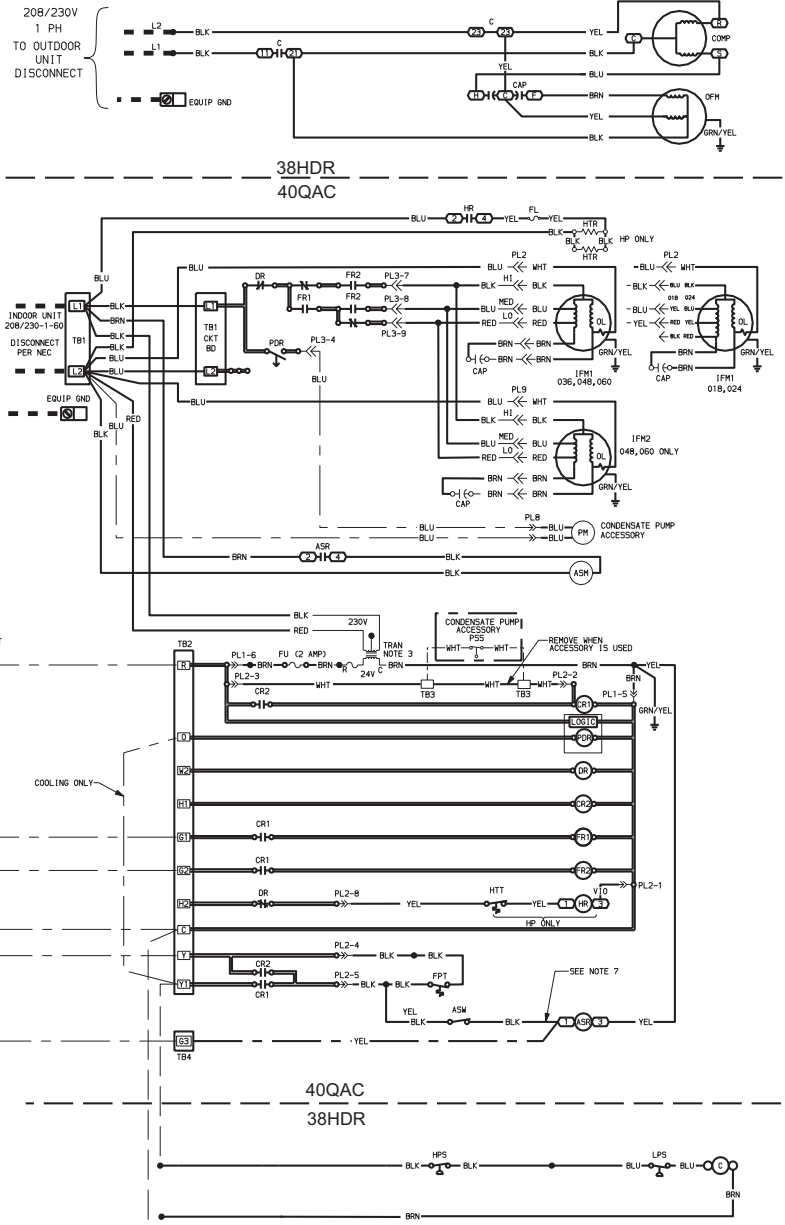

- NOTES:**
1. If any of the original wire furnished must be replaced, it must be replaced with type 90° C wire or its equivalent.
 2. Wire in accordance with National Electrical Code, NEC) and all local codes.
 3. Transformer is thermally protected and will reset automatically.
 4. IFMs, OFM and COMP have internal thermal protection.
 5. Use copper conductors only.

RELAY CHART		
INDOOR FAN HIGH	FR2	
INDOOR FAN MED	FR1, FR2	
INDOOR FAN LOW	FR1	

38HDR and 40QAC Cooling System Wiring Diagram

TYPICAL WIRING SCHEMATICS (CONT.)

40QAC/38HDR -- 40QAC/38QRR

- LEGEND**
- ASM — Air Sweep Motor
 - ASR — Air Sweep Relay
 - C — Contactor
 - CAP — Capacitor
 - COMP — Compressor
 - CR — Control Relay
 - CT — Current Transformer
 - DFB — Defrost Board (Outdoor Unit)
 - DFT — Defrost Thermostat
 - DR — Delay Relay
 - DTS — Discharge Temp. Sensor
 - EQUIP. GND — Equipment Ground
 - FL — Fuse Link
 - FPT — Freeze Protection Thermostat
 - FR — Fan Relay
 - FU — Fuse
 - HP — Heat Pump
 - HPS — High-Pressure Switch
 - HR — Heater Relay
 - HTR — Heater
 - HTT — Heater Temp Thermostat
 - IFM — Indoor Fan Motor
 - LPS — Low-Pressure Switch
 - OFM — Outdoor-Fan Motor
 - OL — Overload
 - PDR — Pump Delay Relay
 - PL — Plug
 - PM — Pump Motor
 - PSS — Pump Shut-off Switch
 - RVS — Reversing Valve Solenoid
 - SSDR — Safety Switch Delay Relay
 - TB — Terminal Block
 - TRAN — Transformer

- Terminal (Marked)
- Terminal (unmarked)
- Splice
- Terminal Block
- Factory Wiring
- Field Control Wiring
- Field Power Wiring
- Printed Circuit Board
- Accessory or Optional Wiring

- NOTES:**
1. If any of the original wire furnished must be replaced, it must be replaced with type 90° C wire or its equivalent.
 2. Wire in accordance with National Electrical Code, NEC) and all local codes.
 3. Transformer is thermally protected and will reset automatically.
 4. IFMs, OFM and COMP have internal thermal protection.
 5. Jumper wire (O to Y1) required when heat pump indoor unit is used with cooling only outdoor unit. Wire must be field supplied.
 6. Use copper conductors only.

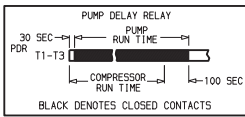
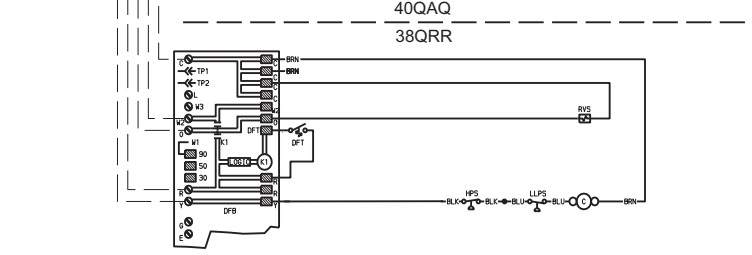
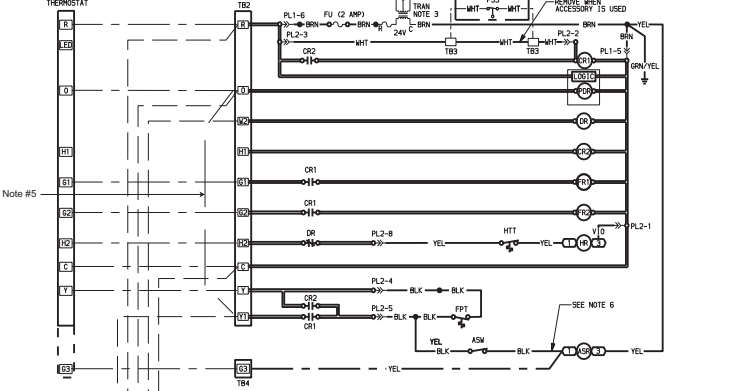
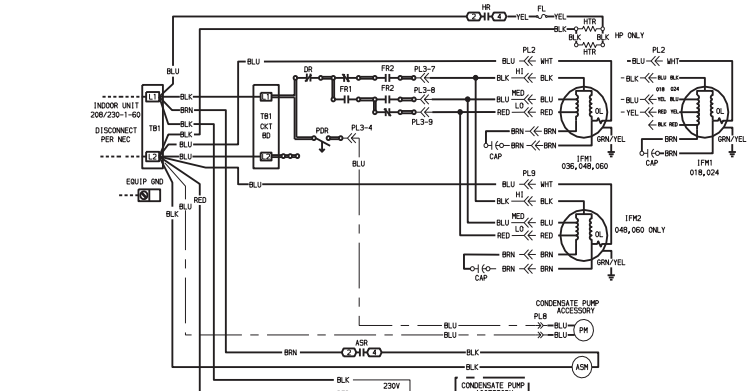
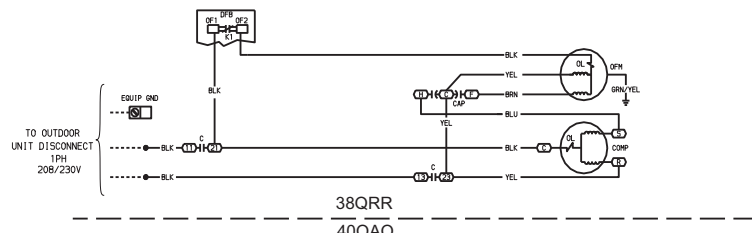

RELAY CHART		
INDOOR FAN	HIGH	FR2
INDOOR FAN	MED	FR1, FR2
INDOOR FAN	LOW	FR1

38QRR and 40QAC Heat Pump System Wiring Diagram

GUIDE SPECIFICATIONS

HORIZONTAL DISCHARGE OUTDOOR UNITS

Size Range: 1-1/2 to 5 Ton Nominal Cooling Capacity / 1-1/2 to 5 Ton Nominal Heating Capacity

Carrier Model Number: 38HDR/38QRR

PART 1 - GENERAL

1.01 System Description

- A. Outdoor air-cooled split system compressor sections suitable for on-the-ground, rooftop, wall hung or balcony mounting. Units shall consist of a scroll compressor, an air-cooled coil, propeller-type blow-through outdoor fan, reversing valve (HP), accumulator, Accurator metering device(s), and control box. Units shall discharge air horizontally as shown on the contract drawings. Units shall function as the outdoor component of an air-to-air cooling only, or heat pump system.
- B. Units shall be used in a refrigeration circuit matched to duct-free cooling only or heat pump fan coil units.

1.02 Agency Listings

- A. Unit construction shall comply with ANSI/ASHRAE 15, latest revision, and with the NEC.
- B. Units shall be evaluated in accordance with UL standard 1995.
- C. Units shall be listed in the CEC directory.
- D. Unit cabinet shall be capable of withstanding 500-hour salt spray test per Federal Test Standard No. 141 (method 6061).
- E. Air-cooled condenser coils shall be leak tested at 573 psig.

1.03 Delivery, Storage, And Handling

Units shall be shipped in one piece and shall be stored and handled per unit manufacturer's recommendations.

1.04 Warranty (For Inclusion By Specifying Engineer)

PART 2 - PRODUCTS

2.01 Equipment

A. General:

Factory assembled, single piece, air-cooled outdoor unit. Contained within the unit enclosure shall be all factory wiring, piping, controls, and the compressor.

B. Unit Cabinet:

- 1. Unit cabinet shall be constructed of galvanized steel, bonderized and coated with a baked-enamel finish on inside and outside.
- 2. Unit access panels shall be removable with minimal screws and shall provide full access to the compressor, fan, and control components.
- 3. Outdoor compartment shall be isolated and have an acoustic lining to assure quiet operation.
- 4. Compressor compartment shall be isolated to allow for diagnostic performance while the system is running.

C. Fans:

- 1. Outdoor fans shall be direct-drive propeller type, and shall discharge air horizontally. Fans shall blow air through the outdoor coil.
- 2. Outdoor fan motors shall be totally-enclosed, single phase motors with class B insulation and permanently-lubricated bearings. Motor shall be protected by internal thermal overload protection.
- 3. Shaft shall have inherent corrosion resistance.
- 4. Fan blades shall be metallic and shall be statically and dynamically balanced.
- 5. Outdoor fan openings shall be equipped with PVC coated metal protection grille over fan.

D. Compressor:

- 1. Compressor shall be fully hermetic scroll type.
- 2. Compressor shall be equipped with oil system, operating oil charge, and motor. Internal overloads shall protect the compressor from over-temperature and over-current.
- 3. Motor shall be NEMA rated class F, suitable for operation in a refrigerant atmosphere.
- 4. Compressor assembly shall be installed on rubber vibration isolators.
- 5. Compressors shall be available in single phase (sizes 018-036) and three phase (sizes 036-060).

E. Outdoor Coil:

Coil shall be constructed of aluminum fins mechanically bonded to seamless copper tubes, which are cleaned, dehydrated, and sealed.

F. Refrigeration Components:

Refrigerant circuit components shall include brass external liquid line service valve with service gage port connections, suction line service valve with service gage connection port, service gage port connections on compressor suction and discharge lines with Schrader type fittings with brass caps, accumulator, reversing valve.

G. Controls and Safeties:

Operating controls and safeties shall be factory selected, assembled, and tested. The minimum control functions shall include the following:

- 1. Controls:
 - a. A time delay control sequence is provided standard through the fan coil board.
 - b. Automatic outdoor-fan motor protection.
- 2. Safeties:
 - a. Diagnostics provided by matched indoor unit.
 - b. Compressor motor current and temperature overload protection.
 - c. Outdoor fan failure protection (High Pressure Switch).
 - d. Low Pressure Protection
 - e. Fusible plug to vent refrigerant safely in case of a fire.

H. Electrical Requirements:

- 1. All sizes shall operate on single phase, 60 Hz power at 208/230v or on three phase, 60Hz power at either 208/230v or 460v for size 035/036 units.
- 2. Unit electrical power shall be a single point connection.
- 3. Unit control voltage to the indoor-fan coil shall be 24 VDC.
- 4. All power and control wiring must be installed per NEC and all local electrical codes.

I. Refrigerant Line Lengths:

Unit shall be capable of 200 ft (61 m) maximum piping run. A maximum lift (fan coil above) of 65 ft (20 m), and a maximum drop (fan coil below) of 150 ft (46 m) accessible will be required to achieve those lengths.

J. Special Features (Field Installed):

- 1. Low-Ambient Kit: Control shall regulate fan-motor cycles in response to saturated condensing temperature of the unit. The control shall be capable of maintaining a condensing temperature of 100°F ± 10°F (37.78°C ± -12.22°C) with outdoor temperatures to -20°F (-28.9°C). Installation of kit shall not require changing the outdoor fan motor.
- 2. Crankcase Heater, Wind Baffle Kit, Stacking Kit, Wall Mounting Kit

40QAC/38HDR -- 40QAC/38QRR

GUIDE SPECIFICATIONS CEILING-SUSPENDED FAN COIL UNITS

Size Range: 1-1/2 to 5 Tons, Cooling Capacity

Carrier Model Numbers: 40QAC / 40QAQ

PART 1 - GENERAL

1.01 SYSTEM DESCRIPTION

Indoor, direct expansion, ceiling-suspended fan coil.

1.02 AGENCY LISTING AND CERTIFICATION

1. A. Systems shall be rated and certified in accordance with AHRI Standards 210/240. Units shall be listed in the AHRI directory as a matched set.
2. Systems shall be listed with UL (Underwriters' Laboratories) and UL, Canada.

1.03 DELIVERY, STORAGE, and HANDLING

Units shall be shipped in one piece and shall be stored and handled per unit manufacturer's recommendations.

1.04 WARRANTY

The 40QA unit is covered by a 1-year parts limited warranty.

PART 2 - PRODUCTS

2.01 EQUIPMENT

A. General:

Indoor, direct-expansion, ceiling-suspended fan coil. Fan coil shall be shipped complete with cooling coil, fan, fan motor, piping connectors, and ceiling mounting brackets.

B. Unit Cabinet:

1. Unit cabinet shall be zinc-coated bonderized steel finished with a baked enamel paint.
2. Inlet grilles shall be attractively styled, high impact polystyrene.
3. Matching mounting brackets shall be provided.

C. Fans:

1. Indoor fans shall be 3-speed centrifugal blower type with air intake in the bottom rear of the unit and discharge in the front.
2. Automatic, motor-driven horizontal air sweep shall be provided standard.

D. Coils:

1. Indoor coils shall be copper tube with aluminum fins and galvanized steel tube sheets.
2. Fins shall be bonded to the tubes by mechanical expansion.
3. A drip pan under the coil shall have a drain connection for the hose attachment to remove condensate.

NOTE: Units use a TXV refrigerant metering device in the indoor unit for cooling only. Heat pumps use the Accurator piston refrigerant metering device in the indoor unit for cooling (except for size 060 which uses a TXV) and an Accurator in the liquid service valve for heating.

E. Motors:

Motors shall be a permanently lubricated ball bearing with inherent overload protection.

F. Controls:

User interface with the unit shall be accomplished via a wired thermostat that shall have the following functions as a minimum:

1. Automatic restart after power failure at the same operating conditions as at failure.
2. Thermostat control to enter set points and operating conditions.
3. Programmable fan speed control shall be user-selectable: high, medium, low, or automatic operation during all operating modes.
4. Automatic heating-to-cooling changeover to provide automatic heating and cooling operation. Control shall include dead-band to prevent rapid mode cycling.

NOTE: See selected thermostat instructions for further information.

G. Filters:

Unit shall have filter track with factory supplied, cleanable filter.

H. Electric Heat

The 40QAQ units shall have a factory installed electric heater with capacity listed in the schedule. The electric heater, when required, shall supplement the heating capacity generated by the heat pump system.

I. Electrical Requirements:

1. Unit shall operate on single-phase, 60 cycle power at 208/230v as specified on the equipment schedule.
2. Unit electrical power shall be a single point connection.
3. Unit control voltage shall be 24-v. All power and control wiring shall be installed per NEC and all local building codes.
4. Unit shall have low-voltage terminal block connections.

J. Special Features (Field Installed):

1. **Internal Condensate Pump:** The condensate pump shall remove condensate from the drain pan when gravity drainage cannot be used. The lift capability of the condensate pump shall be direct vertical 20 inches (508 mm). Float control shall be in the condensate sump to shut the unit down in case of a pump malfunction.
2. **Fresh Air Intake kit:** The fresh air intake kit shall include the filter and duct connections to provide for outdoor ventilation air.
3. **Power Ventilation Kit:** The power ventilation kit shall be used with the accessory fresh air kit when fresh air must be ducted in. The kit will overcome duct static to provide a constant supply of ventilation air. The kit consists of booster fan and adjustable speed control to properly balance the fan to achieve the required airflow rate.
4. **53DFS250-HW Thermostat:** The 53DFS250-HW thermostat shall incorporate 3-speed control, programmability, auto changeover, backlight, locking keypad and a large LCD display.

40QAC/38HDR -- 40QAQ/38QRR