



Product Data



A07045

Fig. 1 - Preferred Series Programmable Thermostat



A07044

Fig. 2 - Preferred Series Non-programmable Thermostat

US patents: US7287709 B2, US20080147242 A1, USD582800 SI, US20060165149 A1, US6956463 B2.



**Designed and Assembled
 in the USA.**

The Bryant™ Preferred Series of thermostats consists of programmable and non-programmable air conditioner, heat pump and Thermidistat™ control. These units feature non-mercury, non-lead based electronic controls built into a subtle, slim plastic enclosure.

FEATURES/BENEFITS

Programmable & Non-Programmable

- Outdoor Air Temperature (OAT) sensor option
- Auto changeover available
- Battery free
- Non-volatile memory to retain settings during a power outage
- Keypad lockout
- English/Metric units selection
- Filter/UV light/Humidifier pad replacement indicators
- Continuous display back-lighting configurable
- Hybrid Heat compatible
- RC/RH power compatible
- 2-wire communicating installation option

Programmable models

- ExP™ expansion port* for use with future enhancements and/or features
- Programmable with personal computer**
- 7, 5-2, All Days programmable
- 4 or 2 periods per day programmability
- Programmable fan by period
- Vacation mode controls temperature and humidity
- Remote room sensor option
- Adjusts automatically for Daylight Savings Time

Non-Programmable models

- Touch-It-Go™ programmability

Air Conditioner Control

- 1-stage heat / 1-stage cool

Heat Pump Control

- 3-stage heat / 2-stage cool

Thermidistat Control

- Heat pump 2-stage or Hybrid Heat 3-stage heat / 2-stage cooling with humidity control
- Humidity display
- Humidify output for direct control of humidifier
- Dehumidify output for variable-speed blowers
- Hybrid Heat compatible

* ExP accessory (expansion port and memory card) sold separately

** Requires ExP accessory

MODEL NUMBER NOMENCLATURE

	1	2	3	4	5	6	7	8
	T	6	-	P	A	C	0	1
Product T = Thermostat							Packaged Quantity 01 = 1 piece	
Series 6 = Preferred							Equipment Type AC = Air conditioning HP = Heat pump RH = Relative humidity	
Not Defined - = Place Holder								
Function Type P = Programmable N = Non-programmable								

T6--PAC / --PHP / --PRH / --NAC / --NHP / --NRH

DIMENSIONS

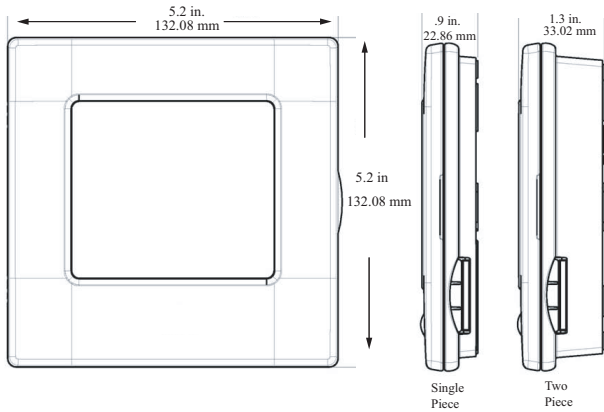

Fig. 3 - Preferred Series Programmable Thermostat

A07137

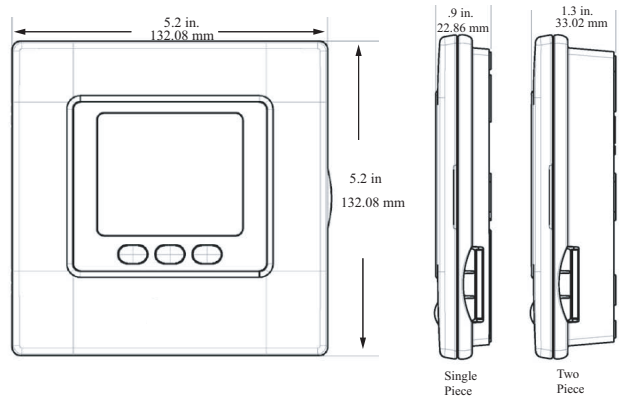

Fig. 4 - Preferred Series Non-programmable Thermostat

A07138

PRODUCT DATA INFORMATION

Physical Characteristics

Dimensions: See drawing
Mounting: Vertical or horizontal J-box provisions

Electrical

Input volts/amps: 24VAC, 3 VA, RC/RH compatible

Environment

Operating temperature/Relative humidity: 32°F (0°C) to 104°F (40°C), 95% RH non-condensing
Storage temperature/Relative humidity: -40°F (-40°C) to 134°F (57°C), 95% RH non-condensing

Wiring Requirements

Standard 18 to 22 gauge, local wiring codes supercede

Accessories

PART NUMBER	DESCRIPTION
TSTATXXSEN01-B*	Outdoor air temperature sensor
T6-EXP	ExP Expansion Memory Port
TX-LBP01	Large decorative backplate for T6-Pxx and T6-Nxx
TX-2WR05	2-Wire harness
ZONEBB0RRS01	Remote room temperature sensor

* The outdoor air temperature sensor must be used with the Thermidistat control in a Hybrid Heat system.

OPERATIONAL INFORMATION

Heating/Cooling Setpoints

The heating/cooling setpoint range is from 50°F (10°C) to 90°F (32°C). A selectable range of 1-6° is enforced between heating and cooling desired temperatures. This is done by allowing one setting to “push” the other, to maintain this difference. (This difference is adjustable in Installer settings.)

Humidify/Dehumidify Setpoint Range

The humidify setpoint range is from 10% to 46% RH in 2% RH increments. The dehumidify setpoint range is from 46% to 66% RH in 2% RH increments.

Five-minute Compressor Time Guard

This timer prevents the compressor from starting unless it has been off for at least 5 minutes. It can be defeated for 1 cycle by simultaneously pressing the FAN button and INCREASE TEMPERATURE (UP) button.

Equipment on indicators

When cooling equipment is ON, a COOL ON icon is displayed. When heating equipment is ON, a HEAT ON icon is displayed. When auxiliary heating is ON (HP only), an AUX HEAT icon is displayed.

Humidify/Dehumidify Output On Indicators (Thermostat Control)

When the operating mode is heat and the HUM output is energized the “humidify” icon shall be displayed. When the operating mode is cool, the dry contact is configured as a DEHUM output and there is a dehumidify demand or the cooling equipment is energized to satisfy a dehumidify demand, the “dehumidify” icon shall be displayed.

Auto Changeover

When Auto Changeover mode is selected, a change from heat to cool (or vice versa) will not occur until an opposite mode demand has existed for 20 minutes. When a setpoint is changed, Auto Changeover timing is ignored to allow the heating/cooling equipment to respond quickly. Auto Changeover mode can be disabled.

Emergency Heat Mode

When the thermostat is controlling a heat pump and emergency heat is selected, all Y signals are locked out, and W becomes energized upon a call for heat.

Smart Recovery (Programmable models)

With Smart Recovery selected, transition out of setback begins a fixed time period (Off, 30, 60, or 90 minutes selectable) before selected recovery time and gradually adjusts room temperature so that the desired temperature will be achieved at selected recovery time.

Room Temperature Offset

Room temperature may be deliberately offset by up to 5° in either direction.

Programmable Fan (Programmable models)

This selection allows the homeowner to program the fan selection to “Auto” or “Fan On” for each of the program schedule periods.

