



Packaged Air Conditioner with Puron® Refrigerant

MODEL 707E



Preferred[™]
SERIES

Environmentally Sound C



Your Preferred Name in Comfort

When your family needs cool relief on a hot summer day, it's good to know you can put your trust in Bryant. Bryant has been the preferred source for home comfort since 1904. We've built a solid reputation by delivering on our promise of comfort, reliability and value. Today, as increasing efficiency requirements impact home comfort technology, Bryant responds with products like the Model 707E Packaged Air Conditioner with Puron® Refrigerant.

The Bryant® Model 707E delivers the comfort you deserve with extra-economical cooling efficiency of up to 16 SEER (Seasonal Energy Efficiency Ratio) and up to 12.5 EER with environmentally sound Puron® refrigerant. And, it's designed, built and backed by America's most reliable source for comfort. When you add professional installation by your trusted local Bryant dealer, the Model 707E is an excellent choice for efficient comfort you can trust.



Efficiency and Comfort Advantages of up to 12.5 EER

When buying a car, most consumers know that the miles-per-gallon rating on the window sticker was attained under carefully controlled conditions. And, you don't just get one rating, you get two – city mileage and highway mileage. The same can be true with published efficiency ratings of packaged air conditioners. Air conditioner efficiencies are measured by both SEER and EER. Many consumers are familiar with SEER ratings which are an average measure of performance under varying conditions throughout the cooling season when a majority of the days typically reach relatively moderate temperatures.

However, it's also important to compare EER ratings – an air conditioner's measured efficiency at a constant 95 degrees Fahrenheit. EER ratings more accurately represent your system's ability to provide cool comfort and energy efficiency during the hottest days of the summer. More importantly, a unit with a high SEER doesn't always have a high EER rating as well. That's why Bryant is excited to offer the Model 707E – an air conditioner that offers high, up to 16 SEER efficiency throughout the season while also delivering high, up to 12.5 EER efficiency when temperatures soar.



The 707E delivers up to 12.5 EER cooling efficiency, meaning you'll stay cool even on the hottest days of the year.

Cooling in an Extra Efficient Package



Peace of Mind

Having a great warranty helps you enjoy your comfort with confidence. Bryant builds trusted reliability into every product, then provides additional peace of mind with excellent warranty protection.

To the original owner, the Bryant® Model 707E packaged product is covered by a 10-year parts limited warranty upon timely registration of your new equipment.* Ask your Bryant dealer about optional extended warranties, which may include labor.

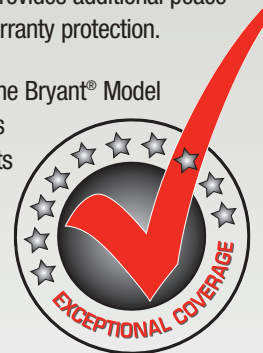

*Parts limited warranty period is 5 years if not registered within 90 days. Jurisdictions where warranty benefits cannot be conditioned on registration will automatically receive a 10-year parts limited warranty. See warranty certificate at bryant.com for complete details.

Performance

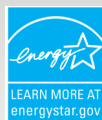

As an ENERGY STAR® Partner, Bryant Heating & Cooling Systems has determined that this product meets the ENERGY STAR® guidelines for energy efficiency. Ask your contractor for details or visit www.energystar.gov.

Enjoy Comfort and Reliability

You can count on energy-efficient cooling with features like our electronically controlled blower motor. For peace of mind, the Model 707E is part of the most reliable product line in our company's history. Our rugged, high-tech base combines a lightweight, rust-resistant composite interior with outer base rails for easier rigging, installation and handling. The unit's interior is protected from moisture with our solid side panels and raised grill/coil configuration. And, three access panels make dealer installation and routine maintenance easier. Designed, built and tested with the most rigorous evaluation standards in the industry, the Model 707E can be the preferred answer for your high-efficiency, high-dependability comfort needs.

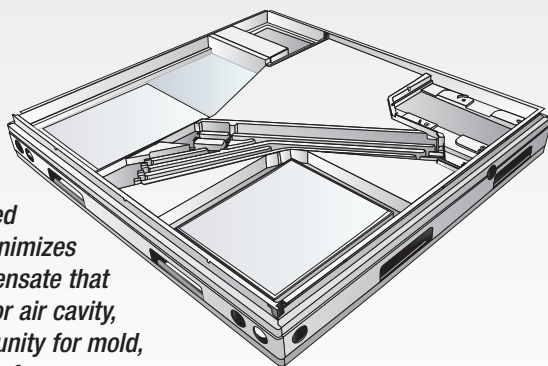

The integrated sloped drain pan design minimizes the amount of condensate that remains in the indoor air cavity, reducing the opportunity for mold, mildew and odors to form.



Take control of your comfort with one of many available Bryant® Preferred™ Series thermostats or controls. Available as programmable or standard, and including our deluxe Thermidista™ control, Bryant offers the styles and features that best suit your needs.

Home Comfort Components

1 ENVIRONMENTALLY SOUND, ENERGY-EFFICIENT

Our two-speed compressor is designed for use with Puron® refrigerant to provide quiet, smooth-operating comfort and years of environmentally sound, trouble-free performance.

2 ENERGY-SAVING BLOWER OPERATION

The electronically controlled motor (ECM) provides airflow optimized for your home's needs. The blower motor offers higher efficiency performance than most standard, PSC-type motors.

3 RELIABLE PERFORMANCE

Our Thermostatic Expansion Valve (TXV) ensures proper refrigerant flow during fluctuating pressures and conditions for top reliability and energy-efficient operation.

4 LASTING COMFORT

High and low pressure switches and the filter drier protect the unit's most important single component: the compressor.

5 DURABILITY AND INDOOR AIR QUALITY

On the inside, our premium base is made from a high-tech composite material that will not rust. Sloped drain pan improves drainage to help inhibit mold, algae and bacterial growth. Out-side, metal base rails provide added stability as well as easier dealer handling and rigging.

6 LASTING LOOKS AND PROTECTION

Rugged exterior enhances unit performance while providing solid protection. Rigid top with large fan opening promotes efficiency and quiet operation. Louvered upper side panels provide proper airflow while protecting the all important coil. Solid cabinet base panels protect against infiltration of dirt, debris and moisture. Three access panels make installation and routine maintenance easy.

7 ENHANCED DEHUMIDIFICATION

Bryant's optional, patented Thermidistat™ Control helps the Model 707E provide enhanced moisture removal for improved summer comfort and efficiency.

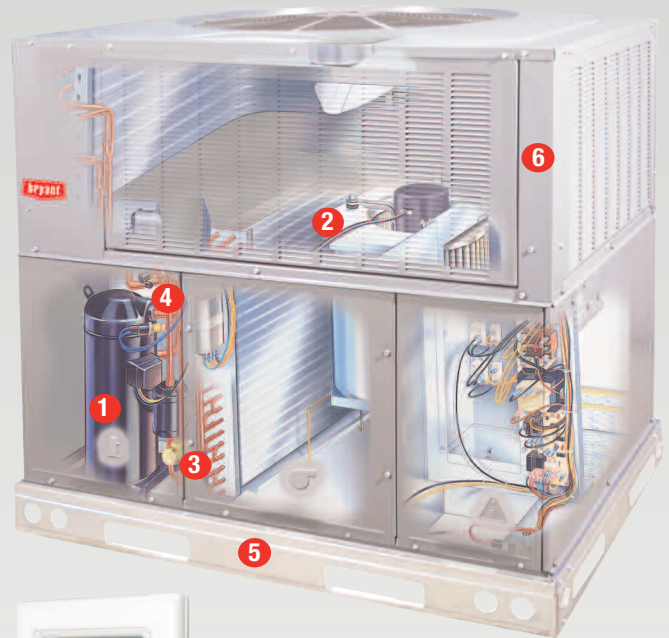

Model 707E

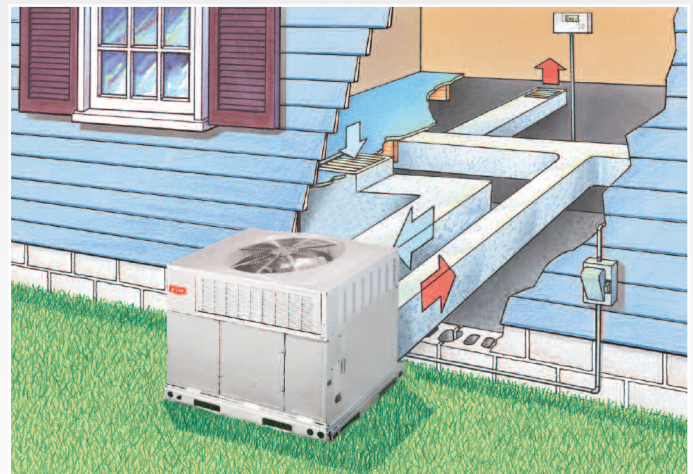

Packaged Air Conditioner System

This Box is to be used as a knock-out for a non-varnished area on a full-spread, full-bleed varnish plate.



Heating & Cooling Systems

A Member of the United Technologies Corporation Family.
Stock Symbol UTX.

01-8707-102-01

© Bryant Heating and Cooling Systems 2013
7310 West Morris Street, Indianapolis, IN 46231

Visit our website at www.bryant.com

Before purchasing this appliance, please read the important energy cost and efficiency information available from your dealer.
Manufacturer reserves the right to discontinue, or change at any time, specifications or designs without notice and without incurring obligations.

