

Curb Mounting

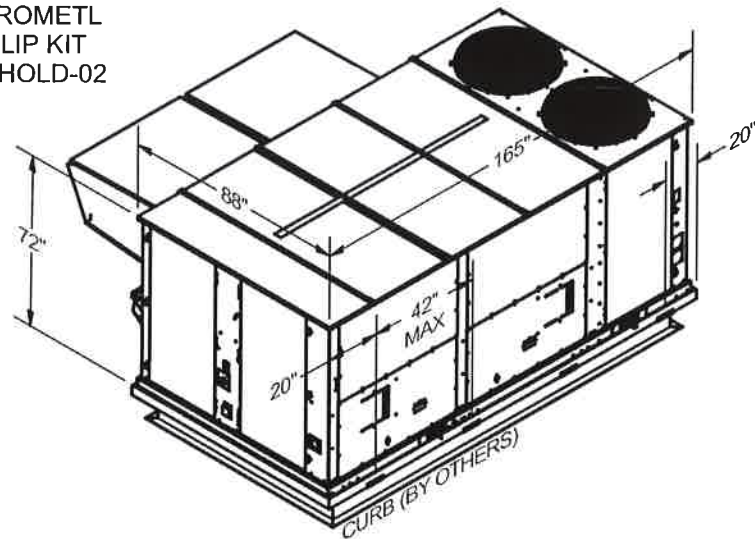

USE MICROMETL CURB CLIP KIT BRK-CRBHOLD-02



PROVIDE (6) 1/4"-14 x 6" BUILDDEX TEK SCREWS AT EACH CLIP
 PROVIDE (4) CLIPS AT CURB ALONG EA. LONG SIDE OF THE UNIT (8 TOTAL)

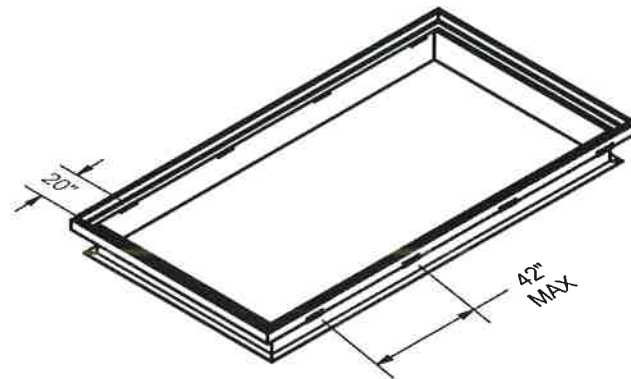

Z-Bracket Installed on Roof Curb prior to installation of seal strip & rooftop.

CARRIER Chassis 48/50A 020 - 035 Series Rooftop Models 20-35 ton WeatherMaker units:

Each package air conditioning unit listed above conforms to the Florida Building Code 5th Edition (2014) requirements for installation including High Velocity Hurricane Zone (HVHZ), Risk Category IV (V = 186 MPH), exposure category "C", and installation height up to and including 100 feet above grade.

ALLOWABLE DESIGN PRESSURES FOR THE UNIT ITSELF:

Design Lateral Pressure = 296 lb/ft²

Design Uplift Pressure = 143 lb/ft²

Unit itself will withstand wind loads imposed by 296 PSF lateral and 143 PSF uplift design pressures provided the 16 gage galvanized base rail are properly fastened to a suitable slab, curb, curb adapter, or other suitable mounting arrangement and all factory supplied assembly fasteners are in place.

See sheet 2 for additional panel screws required.

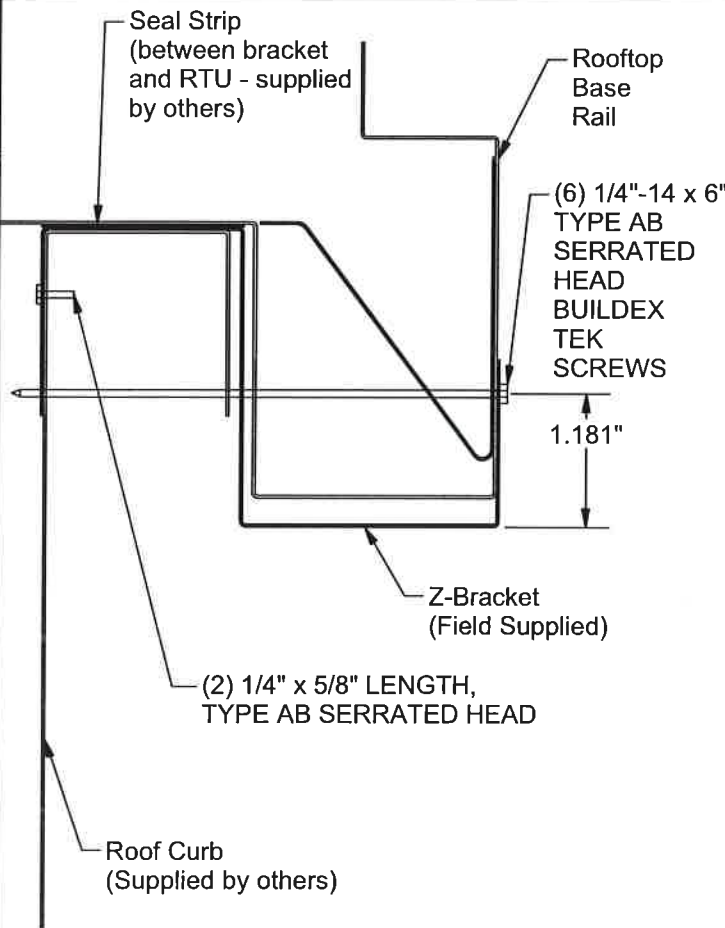
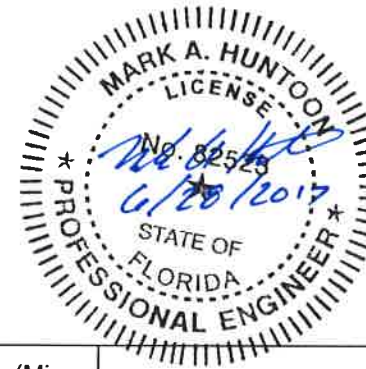

Z-Bracket Wind Load Fastening to Rooftop to Roof Curb.

Optional Mounting - At concrete (Min. 3000 PSI REQ'D) or Hot Rolled Steel.

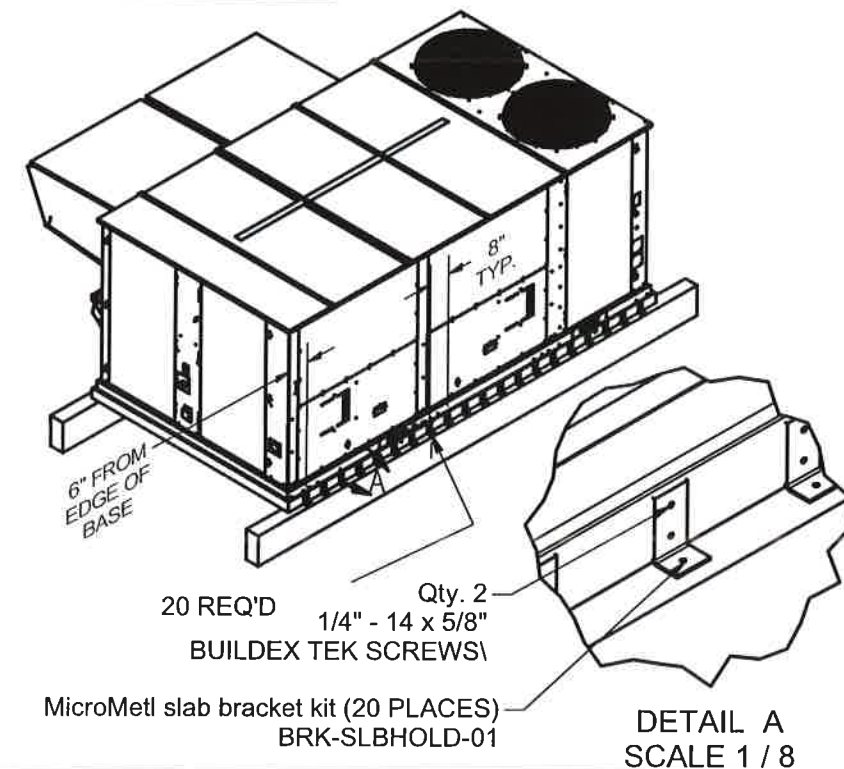

Qty. 1 - 3/8" SAE GR5 Bolt with Nuts and Washers per Clip into Metal Stand (by others), or 3/8" Dia. HILTI KWIK-BOLT TZ Expansion Anchor with 2-1/2" minimum embedment, 2-1/2" Edge Distance and space according to amount of clips required.

1035 W. Glen Oaks Ln. Suite 200
 Mequon, WI 53092
 262-292-1601
 info@j-engineers.com

Job No.: Carrier Rooftop WeatherMaker 020-035 Units

Job No. 060 UNITS

Date: 6/28/2017

Created By: WKF

J ENGINEERING GROUP, LLC.

Sheet: 1 of 2

Title: Model List and Details

S1

NOTE:
SCREW ADDITIONS, LISTED IN BRACKETS, IS BASED
ON MODELS FROM UTC-CARRIER ON 06/12/2017

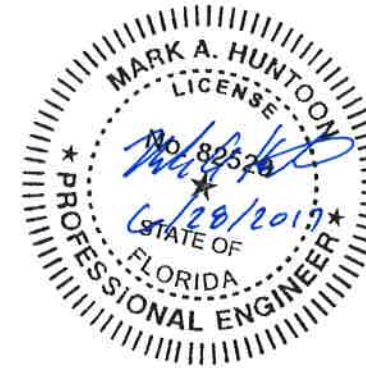
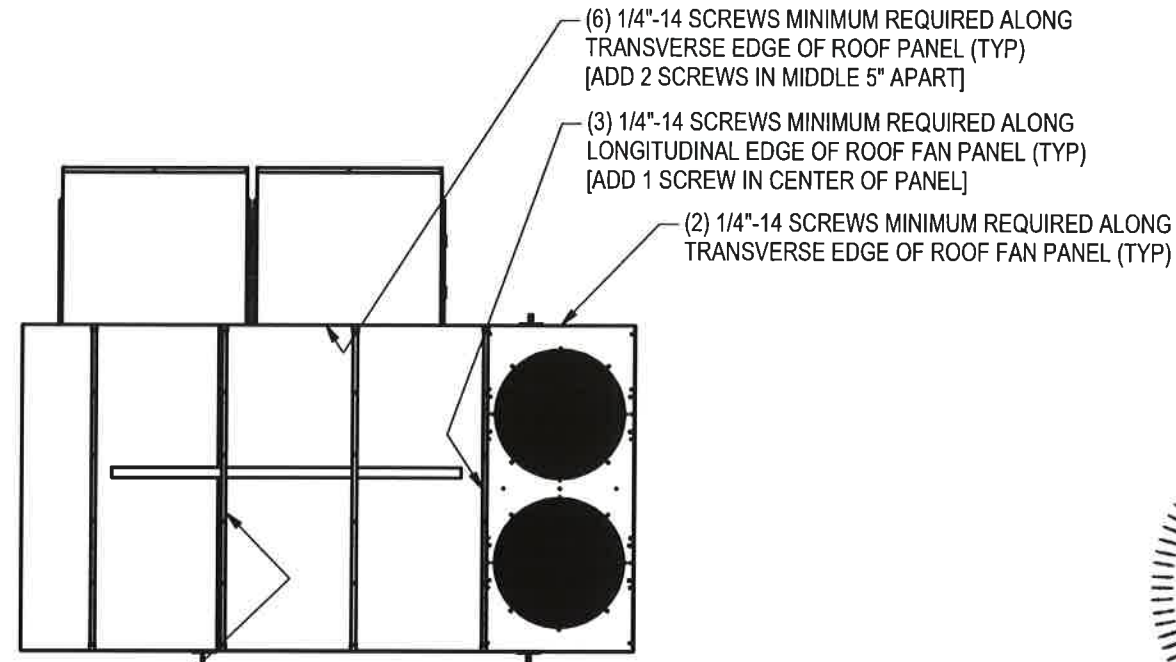

(7) 1/4"-14 SCREWS MINIMUM REQUIRED ALONG
LONGITUDINAL EDGE OF ROOF PANEL (TYP)
[ADD 1 SCREW IN THE CENTER OF PANEL]

(17) 1/4"-14 SCREWS MINIMUM REQUIRED
ALONG HORIZONTAL EDGE OF INTAKE
HOOD (TYP)
[SEE SECTION C-C]

(3) 1/4"-14 SCREWS MINIMUM REQUIRED ALONG
VERTICAL EDGE OF UPPER SIDE PANEL (TYP)
[ADD 1 SCREW IN THE MIDDLE]

(5) 1/4"-14 SCREWS MINIMUM REQUIRED ALONG
HORIZONTAL EDGE OF UPPER SIDE PANEL (TYP)
[ADD 1 SCREW IN THE MIDDLE]

18 GAUGE REQUIRED
ON EXTERIOR PANEL

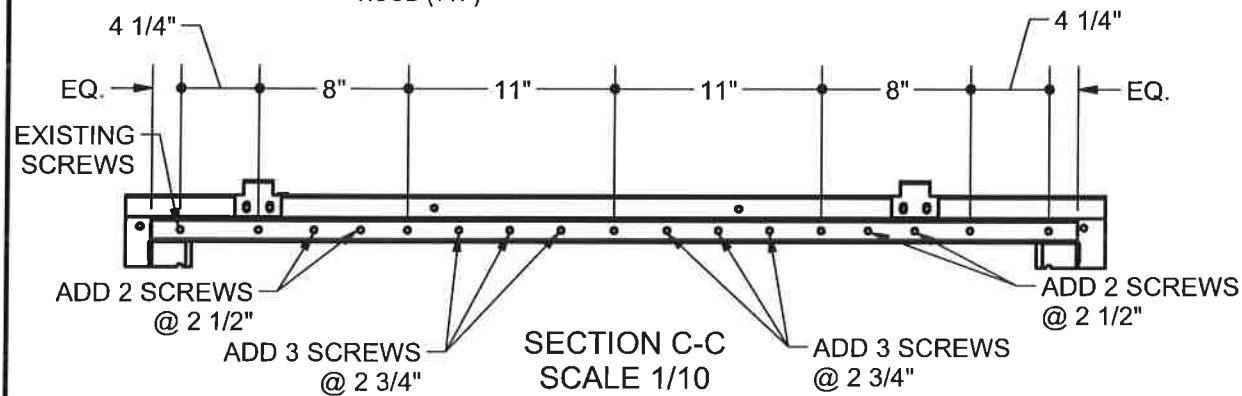
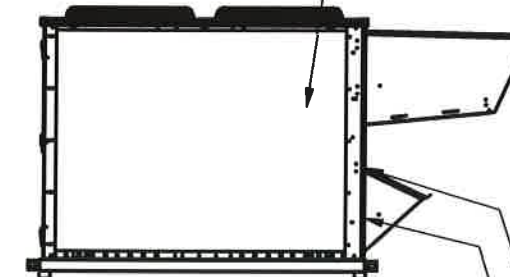
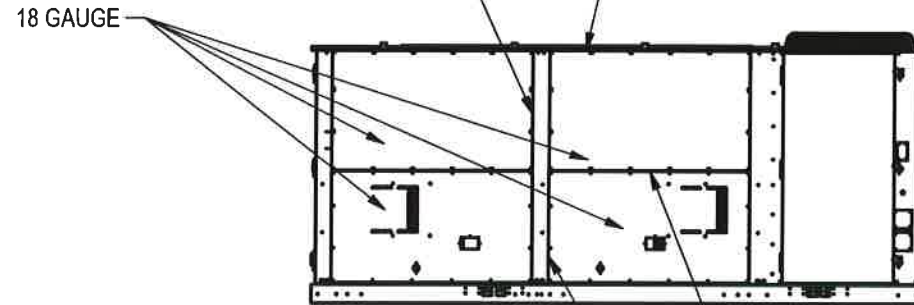
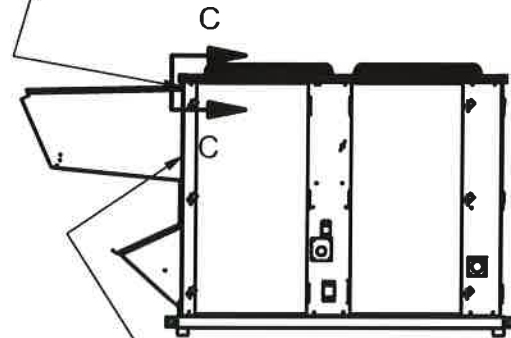

NOTE: SCREW QUANTITIES AND SIZES
IS BASED ON THE ICC ES-1976 REPORT
ON BUILDDEX TEK SCREWS. SCREWS
USED IN ASSEMBLY AS INSTUCTED ON
THIS DRAWING SHALL BE EQUIVALENT
OR SUPERIOR.

1035 W. Glen Oaks Ln., Suite 200 Mequon, WI 53092 262-292-1601 info@jengineering.com	ENGINEERING GROUP, LLC.	Job No.: Carrier Rooftop WeatherMaker 020-035 Units	Sheet: 2 of 2
		Title: Model List and Details	
Job No. 060 UNITS	Date: 6/28/2017	Created By: WKF	
S2			